



**BRIDGEVIEW MFG. INC.**



## ***BALE KING 6300 / 6300TR***

***Bale Processor***

### ***Operator's & Parts Manual***

Last Updated: June 2024



**Bridgeview Manufacturing Inc.**

P.O. Box 4

Gerald, Saskatchewan, Canada

S0A 1B0

Phone: 1-306-745-2711

Fax: 1-306-745-3364

Email: [bmi@sasktel.net](mailto:bmi@sasktel.net)

[www.bridgeviewmanufacturing.com](http://www.bridgeviewmanufacturing.com)

Your Authorized Dealer

Your Serial Number

The Serial Number is located the front tub panel, next to the operator manual box.

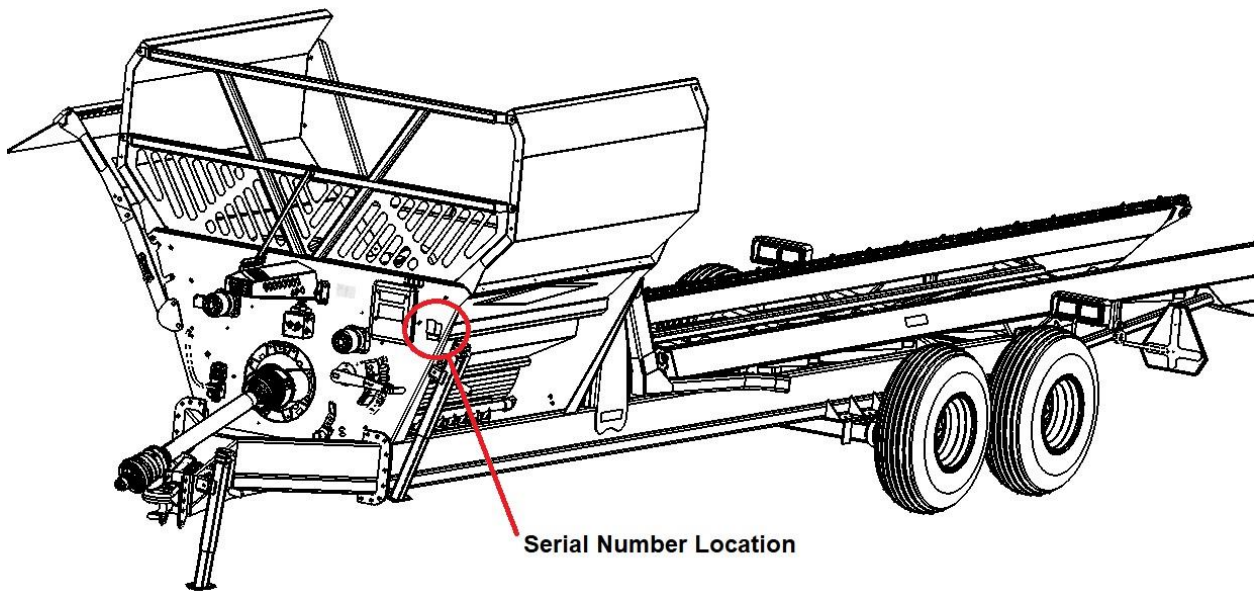

	<p><b>⚠ WARNING</b></p> <p><b>Failure to read and understand operator's manual &amp; all safety signs could result in serious injury. Manual must remain with machine.</b></p>
---	--

**TABLE OF CONTENTS**

INTRODUCTION ..... 1  
    Safety Precautions ..... 1  
    Safety Decals ..... 2  
    Transportation ..... 4  
FEATURES & OPERATION ..... 6  
    Power Take-off ..... 6  
    Hydraulics ..... 10  
    Hose Holder ..... 12  
    Implement Tongue ..... 13  
    Torflex Axles ..... 13  
    Loading Bales ..... 14  
        Loading Fork ..... 15  
    Hoop Grate Adjustment ..... 16  
    Agitators ..... 17  
    Deflector ..... 18  
    Optional Fine Chop Kit ..... 20  
    Optional Total Ration Grain Tank (6300TR) ..... 21  
SERVICE AND MAINTENANCE ..... 22  
    Greasing Locations ..... 22  
    Wheels & Tires ..... 25  
    Twine Removal ..... 27  
    Feeding Chain ..... 28  
    Gearbox and Flail Replacement Procedure ..... 29  
    Trouble-shooting Guide ..... 30  
    Features and Specifications ..... 31  
PARTS MANUAL ..... 33  
HYDRAULIC SCHEMATICS ..... 75  
NOTES ..... 84

## **INTRODUCTION**

Thank you for purchasing a **Bale King** bale processor. With the proper operation and service as outlined in this manual, the Bale King will provide you with years of trouble-free operation.

This is a complete safety, operation and parts manual for the Bale King 6300. The manual covers in detail how to safely and effectively use your new processor. The procedures outlined in this manual should be followed to ensure safe operation and longevity of your machine. The parts manual covers all parts you may need to order in case of accident or breakdown. Please read completely through this manual before beginning operation of your new machine.

### ***Safety Precautions***

**The following safety precautions MUST be followed to ensure safe operation of the Bale King bale processor.**

- **ALWAYS** turn **OFF** the tractor when leaving the operating platform.
- **DO NOT** stand in front of the discharge chute while the machine is running.
- **DO NOT** walk or move under the bale forks when they are in the upward position, unless the cylinder safety lock is in place.
- **DO NOT** enter the machine while in operation.
- **DO NOT** clean machine while in operation.
- **DO NOT** stick any device into the machine to clear debris while the machine is in operation.
- **ALWAYS** turn off the machine when cleaning the machine, removing twine, or hooking / unhooking the machine
- **ALWAYS** use safety chain when towing the machine on a highway.
- **DO NOT** operate if any part of the **PTO safety shielding** is missing or is not secured.

## Safety Decals

### Power Take-off:

The operator must obey all safety labels and must maintain the proper shielding. A high percentage of drive-line injuries occur when safety shielding is missing or not functioning properly.

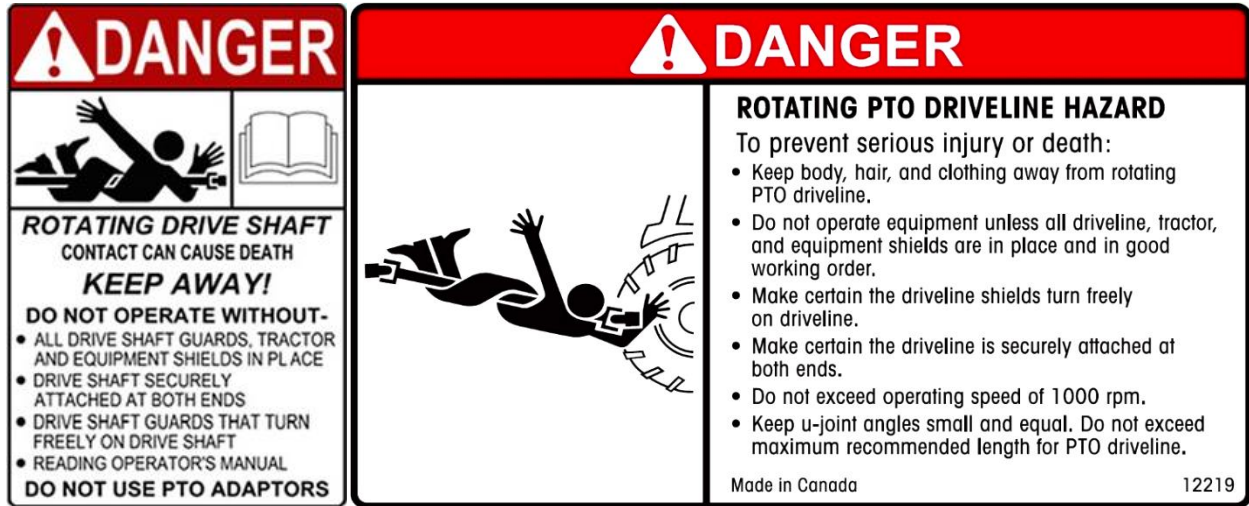

**DANGER:** *Contact with a rotating drive-line can cause serious injury or death.*

### Discharge:



**DANGER:** *Do not stand on the discharge side of the machine while it is in operation.*



### Rear Fork Lift Area:

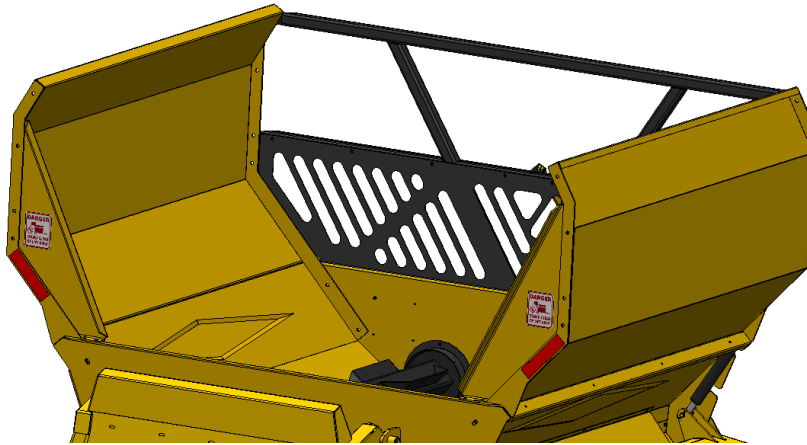

**DANGER:** *Stand clear of lift area. Do not stand under the forks if tractor is running or if bale is resting on forks. Automatic hydraulic safety locks are installed.*

### Deflector Safety Lock:

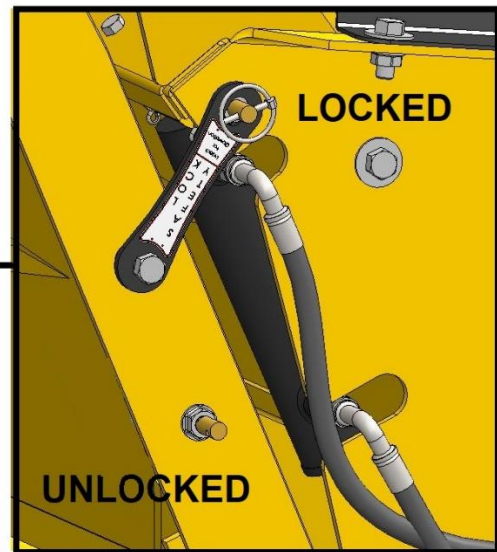

*Unlock for operation, Lock for transport and storage*

## Transportation

The Bale King 6300 can be safely towed on public roads, provided the following precautions are met:

### Weights and Dimensions

- The towing vehicle must be suitable for the weight being towed.
- Check with local authorities regarding transport on public roads. Follow all applicable laws and regulations.
- Be aware of your size and weight. Adjust your driving accordingly

	Empty		Loaded	
	6300	6300TR <sup>1</sup>	6300	6300TR <sup>1</sup>
Total Weight	9060 lb	9700 lb	19200 lb	21400 lb
Hitch Weight	3100 lb	3400 lb	3600 lb	3800 lb
Length	39'-10"			
Width <sup>2</sup>	9'-10"	10'-8"	9'-10"	10'-8"
Height	8'-9"		10'-0"	

NOTE 1. The 6300TR features the optional Total Ration grain tank

NOTE 2. Width can be reduced to 8'-6" by folding the deflector

### Speed

Tow Vehicle Weight	Empty Processor	Loaded Processor
15000 lb and Under	32 km/h (20 mph)	Not recommended
Over 15000 lb	40 km/h (25 mph)	32 km/h (20 mph)

- The processor features implement tires and hubs and is not suitable for high speed travel
- The processor does not have brakes.
- Slow down for rough conditions, turns, and steep declines.
- If towing long distances, ensure the machine is empty (no bales in tub or on fork)
- If hauling one bale only, place it in the tub instead of on the fork.
- If hauling up to six bales, speed should be further reduced. Make sure that one bale is loaded into the tub, and the remaining bales are shuttled forward to reduce the risk of falling off the bale. Note that there will still be a significant amount of weight behind the axle, causing more "tail whip". This also raises the center of weight of the machine.
- Failure to heed these warning may result in loss of control or death.

**Safety Chain, Jack, PTO, and Hydraulics**

- ALWAYS ensure that the safety chain is properly installed. There should be enough slack to allow for turning, but not so much that the chain drags on the ground.
- Ensure that the jack is installed in its storage position on the front tub wall.
- Ensure that the PTO and hydraulic hoses are properly secured
- PTO and hydraulic lines must be connected to the tractor during transport.
- If towing with a pickup, the outer PTO shaft must be removed, and the inner shaft and hydraulic hoses properly secured. The exposed end of the inner PTO shaft should be covered to protect the splines from dust/rocks, etc.

**Wheels and Tires**

- Check tire pressure and wheel torque. Wheels must be retorqued after 1 hr if being transported for the first time.

<b>Tire Pressure</b>	35 psi	<b>Wheel Torque</b>	125 ft-lb
----------------------	--------	---------------------	-----------

- If transporting long distances, periodically check the tires and hubs for high temperatures. If heating up, you must slow down.

**Lights and Marking**

- Tow vehicle must have a 7-pin round trailer plug
- Plug in lights and check for proper function and visibility (flashing amber lights, red tail lights and brake lights).
- If towing with a pickup, an adapter will be required to plug into the trailer plug. When braking, both amber lights should activate. Tail lights should always be on.
- Ensure that the supplied SMV (Slow Moving Vehicle) sign is clearly visible from the rear
- Ensure that the reflective markers are cleaned, and visible from all sides

**Safety Locks**

- If possible, the deflector should be in the folded position.
- Ensure that the deflector safety lock is installed





## FEATURES & OPERATION

### **Power Take-off**

The Bale King bale processor has a PTO shaft which is splined on both ends. The implement end uses a 1-3/4"-20 spline with wedge lock bolts. Install onto the gearbox and tighten the wedge bolts. The bolts should be torqued to **160 ft-lb** and re-torqued after 8 hrs of use.

The tractor end comes standard with a 1-3/8"-21 spline quick detach constant velocity joint. An optional 1-3/4"-20 spline yoke is available through your Bale King dealer.

The Bale King processor is designed to use a minimum of **100 HP**. The drive shaft is shear-bolt protected. The machine must be operated at **1000 PTO RPM**.

**NOTE: *Spread yokes and twisted drive shafts are signs of OVERLOAD, not a manufacturer's defect and therefore not covered by warranty.***

- **DO NOT** operate the machine using a spline adaptor. Use of adaptors will **void warranty** due to damage caused to the tractor PTO, PTO driveshaft, or implement.
- **DO NOT** operate at 540 rpm, or use any kind of adaptor to connect to a 540 rpm spline.
- **ALWAYS** ensure that the PTO shaft is attached securely to the tractor. When the processor is not hooked to the tractor, store the shaft on the PTO holder.
- **DO NOT** transport the processor without securing the PTO shaft. See next page for securing instruction.
- **ALWAYS** ensure that the drawbar is adjusted to **16"** from the end of the tractor PTO shaft to the center of the hole in the drawbar.

### **Operation**

To engage the rotor for processing a bale, be sure the PTO shaft is properly connected to the tractor. Engage the PTO at idle. After the PTO is fully engaged, increase PTO speed until it reaches 1000 RPM.

The processor must not run at any speed less than 1000 PTO RPM as it may result in the flails springing back against the rotor after they come in contact with the bale. This "***backslap***" may cause flails to fatigue and excessive vibration which may cause the bearings to fail. Bales may be dumped into the tub while the rotor is stopped or while it is running.

## Shear Bolt

All new Bale King processors are equipped with a **shear bolt** clutch located at the implement end of the PTO shaft. The correct size shear bolt is **3/8 x 2" Fine Thread Grade 5 with Stover Lock Nut**. Any other size or grade will **damage** the shear assembly. Spare shear bolts are shipped with each new machine and are stored along the front top lip of the tub.

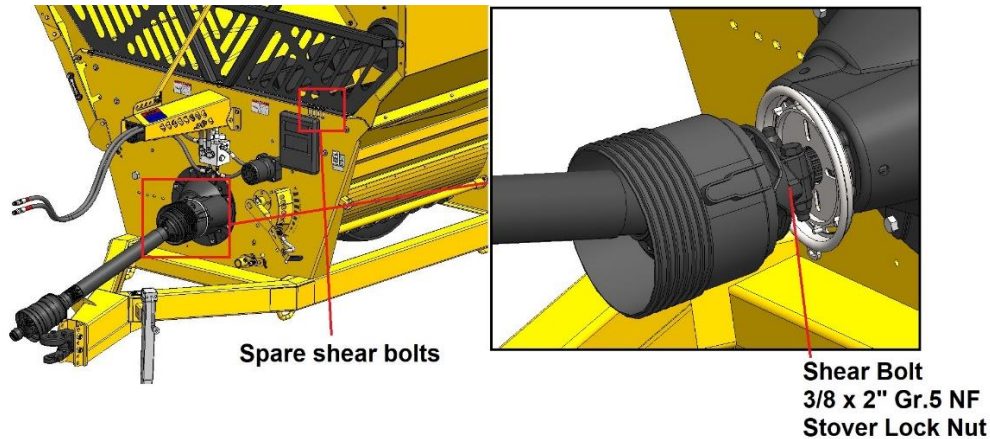

If your shear bolt is shearing excessively you may be over-loading the machine. If this occurs raise the grate assembly to make the machine less aggressive, or roll the bale more slowly. **Always ensure that your machine is running at 1000 PTO RPM.**

**NOTE: Please consult your local dealer to help pinpoint any problems.**

## PTO Holder

A PTO shaft holder is standard with your new Bale King, for safe storage of the PTO shaft when the processor is not in use.

When unhooking the PTO shaft from the tractor, retract and then swing the PTO to the right to rest the PTO on the holder.

DO NOT transport the machine with the PTO in the holder. Slide the outer PTO shaft out and secure elsewhere. When transporting, fasten the inner PTO shaft to the machine and cover the open splined end.

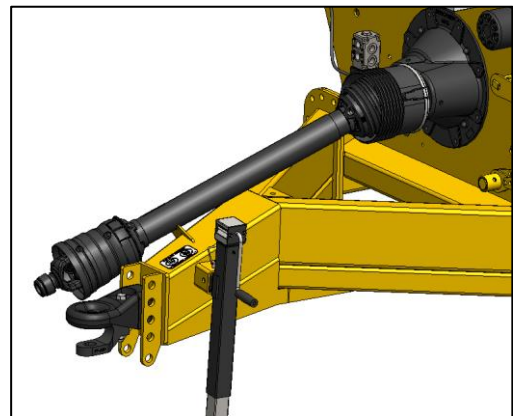

## PTO Use and Maintenance

Shut **OFF** the tractor engine and remove the key before doing any maintenance on the machine. Use **ONLY** genuine **Weasler** parts when replacing any worn or damaged PTO components.

### *Length:*

Confirm the minimum and maximum working lengths of the drive-line. The telescoping tubes must overlap at least 1/3 of their length when in use. The PTO is designed to be used with a drawbar length of 16" from the end of the PTO shaft. Adjust your tractor accordingly.

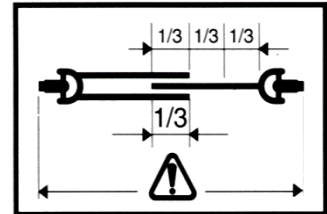

### *Shielding:*

Be sure that the shielding is not damaged and rotates freely on the drive shaft.

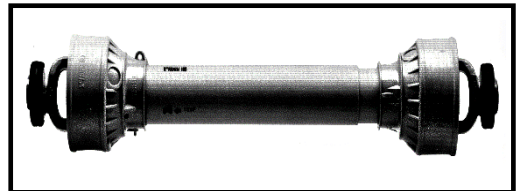

### *Working Angles:*

Constant Velocity joints can operate up to 80 degrees for short periods of time. Do not operate for long periods on sharp angles.

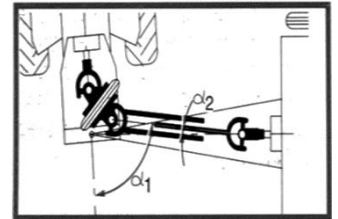

### *Attachment:*

Be sure the drive-line is properly attached and all bolts and screws are tight on the implement input shaft and on the tractor PTO shaft.

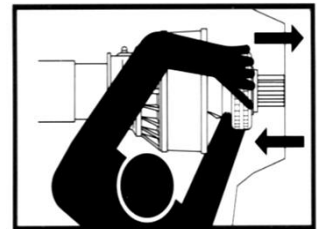

### *Storage:*

When not in use, cover or protect the drive shaft from the weather.

When removed from the machine store both halves together to prevent damage. Check all components for proper function and lubrication before use.

**BEFORE ATTEMPTING ANY REPAIR PROCEDURES,  
ALWAYS USE APPROPRIATE EQUIPMENT SUCH AS  
SAFETY GLASSES, SAFETY SHOES, AND GLOVES**

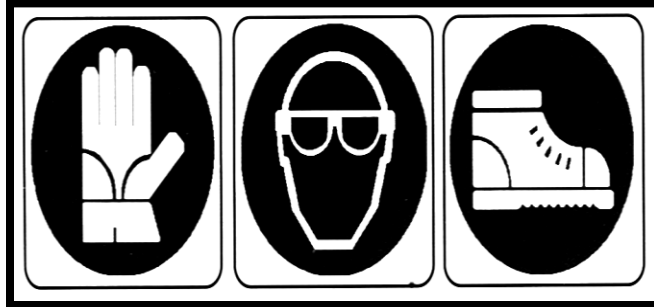

*Shield Removal:*

- To remove the shield, pop out the red snap, then rotate the guard on the bearing to line up the three tabs with the openings and pull it off away from the knuckle joint.
- Remove the nylon bearing from the shaft by spreading it open.



*Shield Assembly:*

- Be sure to lubricate the groove in the inner yokes where the shield bearing rides. Reinstall shields in the reverse order that they were removed.



## Hydraulics

**WARNING:** *Pressurized hydraulic fluid can cause serious injury.*

- When working with hydraulic equipment, eye and hand protection should be worn.
- Do not test for leaks with bare hands.
- Relieve any pressure before removing a hose or fitting.
- Never work under components raised by hydraulic equipment unless supported externally.
- Always set the tractor's hydraulic flow at a lower rate and adjust it upward until the desired speed is reached. Excessive oil flow may damage the flow divider cartridge.



There are three sets of hydraulic hoses to connect to the tractor. Each hose has a coloured marker to identify its function. They should be connected at best convenience for the tractor's controls. Note that the hoses are paired by colour and the following tables show the operation when pushing oil into the hose with the longer marker.

Control Box	Hose Function		
	“AUXILIARY”	“FORK”	“DEFLECTOR”
Long Blue	Lift bed	Lifts rear fork	Lift deflector
Long Yellow	Conveyor chain towards tub		
Long Red	Turns agitators clockwise		

The Bale King 6300 processor has a diverter kit which allows it to operate using only 3 hydraulic remotes. The fork, deflector, and bed tilt functions are then controlled by a cab-mounted switch box. This box must be wired up to the tractor's electrical system. You may use the provided plug to plug into the accessory outlet. If this is not available, the plug can be disassembled, and wired as necessary.

A 4-pin plug is used to power the diverter valve on the processor. If no power is supplied, the hydraulics will still control the rear forks, but the deflector will not be functional. If the switch in the tractor is activated, the deflector can be controlled.

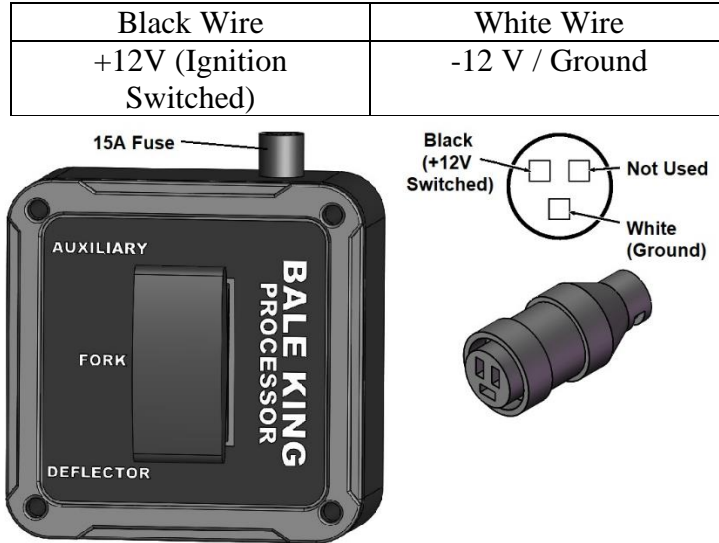

An optional grain tank kit is available to allow the Bale King 6300 to carry 40 bushels of grain on the side of the machine (see page 21). If this kit is installed, additional motors are added to the hydraulic functions. This changes the hydraulic setup as shown below. A different control box is also required, which has an additional push button switch to control the grain tank.

<b>6300TR – 3 Remote</b>				
<b>Control Box</b>	<b>“AUXILIARY”</b>	<b>“FORK”</b>	<b>“DEFLECTOR”</b>	<b>“GRAIN TANK”</b>
<b>Long Blue</b>	Lift bed	Lifts rear fork	Lift deflector	Discharge grain
<b>Long Yellow</b>	Conveyor chain towards tub			
<b>Long Red</b>	Turns agitators clockwise			

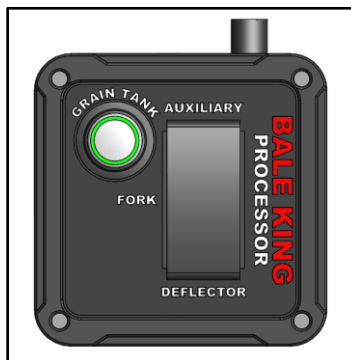

\* 6300TR Control Box with additional push button switch



## Hose Holder

The hydraulic hoses may need to be adjusted to avoid damage from rubbing on the PTO shaft. This can be done by lifting or lowering the hose holder. Loosen the pin handle, then lift the end of the hose holder to drop the pin into the slot. Then adjust the height as desired and catch the pin into the desired notch. Finally, retighten the pin handle to prevent it from switching positions if the machine bounces.

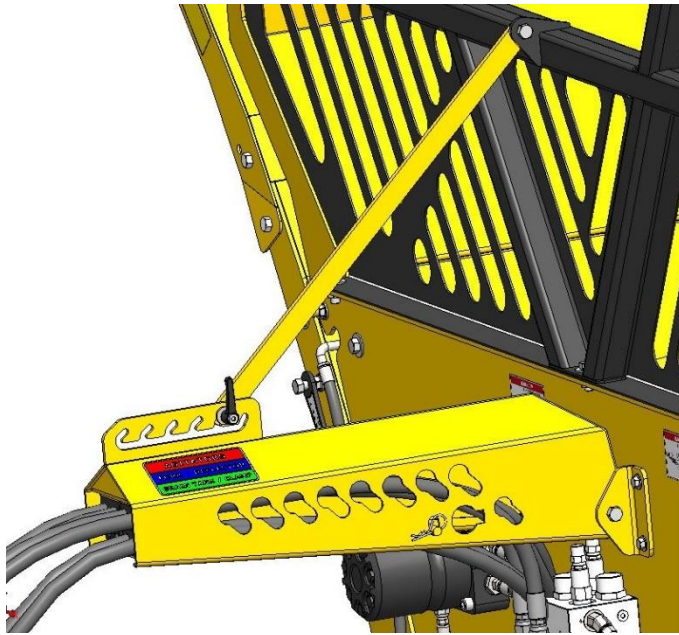

Loosen handle  
Lift end of holder  
Slide pin in slot  
Choose setting  
Tighten handle

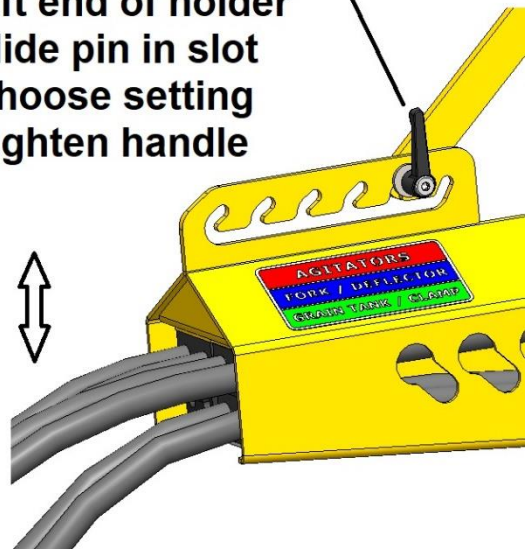

## Implement Tongue

The adjustable hitch on the Bale King features a cast single tongue with optional clevis insert (**BMI #23404**). This allows for use with tractors equipped with a hammer strap or with a single drawbar. It also allows the machine to move independently over rough terrain without bending the draw pin.

- Make sure that the drawbar is set to **16 inches** behind the PTO shaft for proper PTO length.
- Adjust the hitch height to match the tractor drawbar height as close as possible. When properly adjusted, the frame rails should run level.
- **DO NOT** install the clevis insert if using a tractor with a hammer strap as this will bend the hitch pin.
- **ALWAYS** connect the safety chain during road transport

## Torflex Axles

The Bale King 6300 features a pair of Torflex axles, which provide suspension and allows a smooth ride over rough terrain.

There are 3 available mounting locations available. From factory, axles are set up in the middle position. Axles can be moved forward to slightly reduce hitch weight on tractor, or rearward to slightly improve handling (by reducing tail swing).

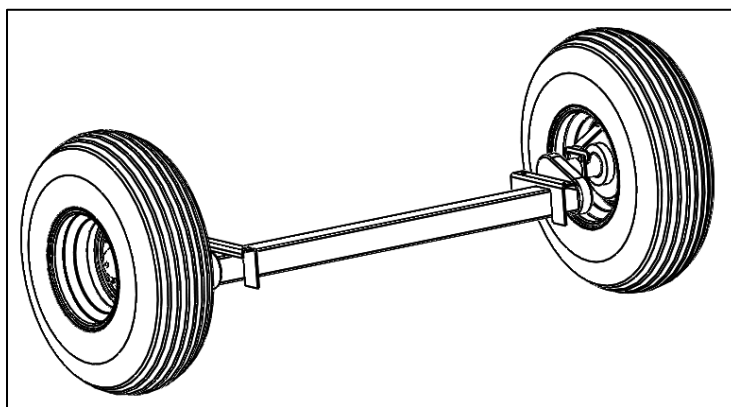

## Loading Bales

When loading bales into your Bale King bale processor, the following procedure should be followed:

- Position the processor so that the back of the deck is aligned with the center of the row of bales you wish to load. Align the processor so that you can back straight into the row.
- Raise the deck until the skid shoes gently touch the ground.
- Back slowly under the row of bales and rotate the conveyor chain to draw the bales up the deck, matching tractor speed to the chain speed. Let the chain run until the first bale reaches end of the deck.



- Stop rotating the chain and load the first bale into the tub with the fork. Make sure to fully lower the fork once the bale is in the tub.



- Rotate the conveyor chain to draw bales up onto the deck while backing slowly under the row of bales to pick up one more bale.



- Lower the deck once the final bale is loaded. Allow the tractor to roll forward as you lower the deck to avoid nudging the remaining stack of bales.



**TIP:** Once the bale is on the deck, lower the deck slightly to minimize twine build-up on the rear sprocket.

## Loading Fork

The loading fork on the Bale King 6300 can handle up to 6.5ft bales. The loading fork is designed to load bales into the tub while the deck is inclined or flat. The fork design allows an operator to load all six bales without repositioning the bed tilt.

- Finish processing the bale that is currently in the tub. If dropping a new bale onto an unfinished one, the material may pile up and prevent turning of the bales.
- Use the chain to make sure that the bales are pulled tight up to the fork
- Lift the fork to tip the bale into the tub. You may slow it down at the end to allow the bale to fall more gently into the tub.
- It is common practice to leave the rotor running while the new bales are being loaded. However, the agitators should not be turning.
- Fully lower the fork.



**Never stand under the forks. When greasing or servicing around the rear end, the forks should be down. Never attempt to loosen or replace hydraulic hoses while the forks are up.**

## Hoop Grate Adjustment

There are eight adjustment settings for the hoop grate on the bale processor. These settings determine the rate of feed of the bale you are processing and the how fine the cut will be. To adjust, pull the spring handle outward, then swing the handle “UP” for a more aggressive cut, or “DOWN” for less aggression. Then release the spring handle to engage the pin in the desired hole

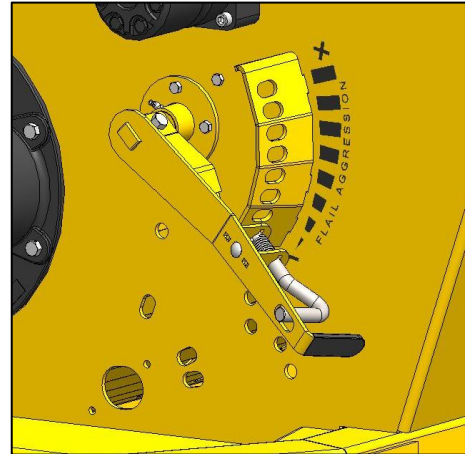

When there is a bale in the tub, the bale’s weight will be placed on the hoop grates, making adjustment more difficult. Adjust the machine when it is empty when possible.

- **Position #1 (Bottom):** Highest grate setting for finest cut and slowest rate of feed. Used for tough processing feeds such as silage bales, or other wet materials.
- **Position #2 - #5:** Normal operating range. Machine gets more aggressive as grate is lowered (handle moves “up”).
- **Position #6-8 (Top):** Lowest grate positions, most aggressive, fastest rate of feed.

The Bale King should be adjusted according to bale conditions to achieve a rate of feed of approximately **1.5 to 2 minutes**. Light brittle material such as wheat straw may allow faster processing while tough stringy material such as slough hay, green feed, or flax will require slower processing. Hoop grate adjustment should be checked periodically.

**NOTE:** *Processing a bale too rapidly may cause unnecessary machine deterioration.*

**NOTE:** *Upper grate position should be approximately 1/8” flail protrusion. Lower grate position should allow 2-1/2” flail protrusion. Contact your Bale King dealer if this can’t be achieved.*

## ***Agitators***

The Bale King is equipped with a flow divider/combiner and two hydraulic motors for turning the bale.

Once the main rotor is turning at full speed the bale can be turned in either direction to begin processing. The faster the bale is turned in either direction, the faster it will be processed. It may be necessary to change direction of the bale when loose debris builds on either side of the bale chamber. This will remove the loose debris preventing spillage from the machine. This is especially true when processing soft core bales. By reversing direction regularly, soft core bales will process more evenly.

If the tractor has a flow control, adjust the oil flow so that the agitators run at a low rate. Adjust the flow as needed to find the best speed to process a bale (approximately 30 rpm or 12 gpm flow). Turning bales too fast can result in rotor overloading resulting in flail “backslap” which in turn causes flail and bushing damage. High agitator speed may also cause damage to the hydraulic motors and excessive twine and material build-up on the agitators.

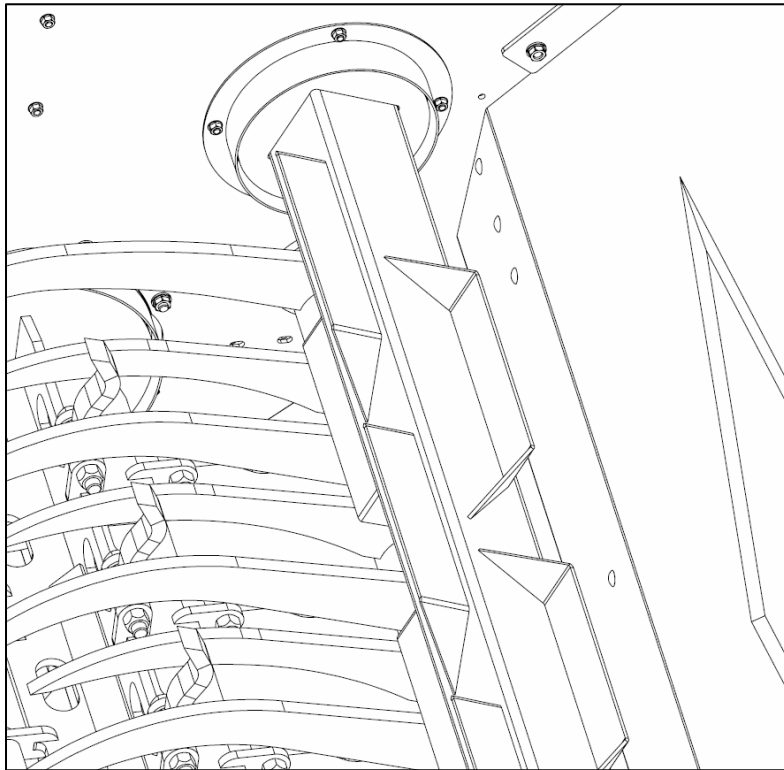



## Deflector

The Bale King 6300 is equipped with a hydraulic side deflector to change the discharge distance and distribution. It also comes with a flipping rubber flap for superior control of the spread pattern.

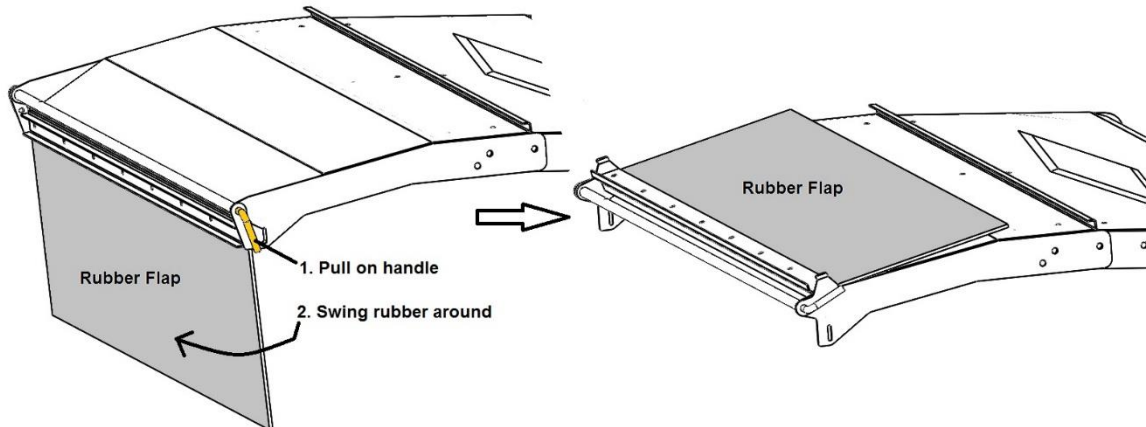

Moving the deflector to the **down** position and flipping the rubber down (above left) will allow the hay to be laid in a windrow, or bunk feeder. Swinging the deflector **up** will allow you to spread straw out over a large area. If you also flip the rubber up (above right), you will be able to "fine tune" the discharge, to control the height and distance.

To flip the rubber, simply pull on the handle and swing into position. Then push the handle so that the tabs catch in the notches and lock into place.

The Bale King 6300 deflector will bunk feed to a distance of 35" from the tire when in the lowest position. When the deflector is not folded, the transport width of the machine is 9'-10".

For transport and storage, the deflector lock should be put in place by swinging the lock as shown and fastening with a lynch pin.

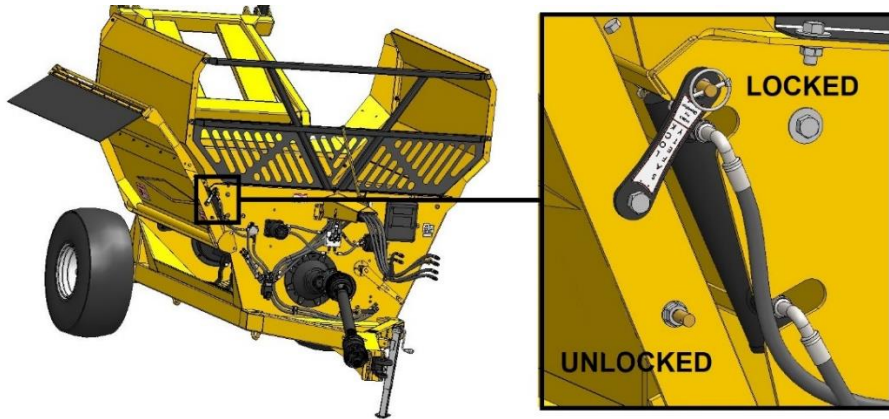

The Bale King 6300 deflector also has the ability to fold for more compact long-term storage or long-distance transport.

- Move the deflector to its lowest position
- Remove the 7 top carriage bolts from the deflector.
- Loosen all the 4 bolts on the front and back of the deflector.
- Raise the deflector to its highest position with the hydraulics. Remove the bolts closest to the machine center (both front and back) and swing the outer deflector down.

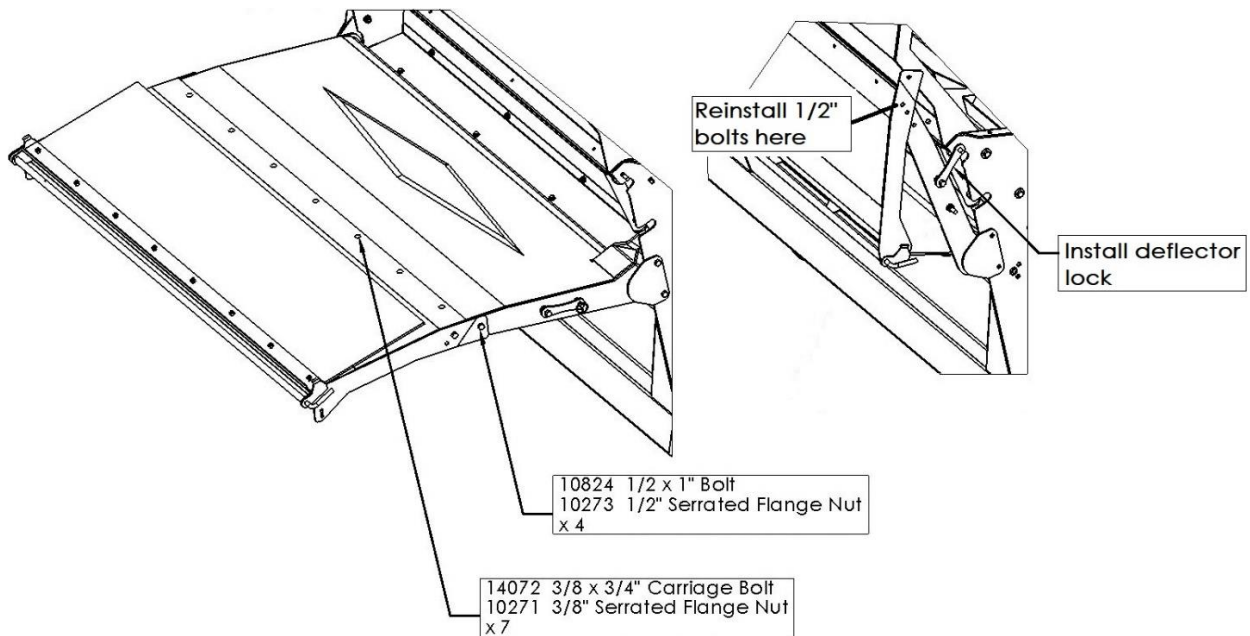

## Optional Fine Chop Kit

The Bale King 6300 processor has an optional fine chop knife kit (**BMI # 32117**) available to go into the lower tub area. This option is available if you require a finer cut on the material which you are processing such as slough hay and silage bales.

It is recommended that the knives be lowered when bedding straw as it will affect your spread pattern. Adjust the machine as needed.

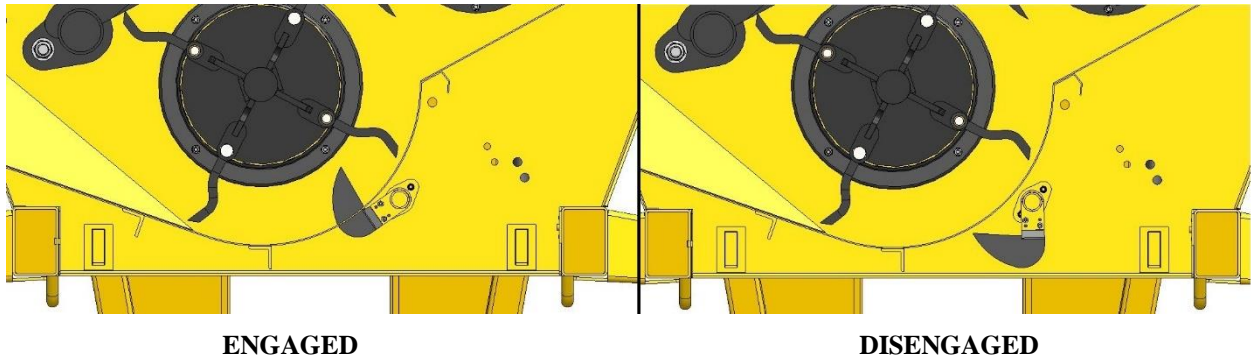

There are two settings for the fine chop, depending on how fine you wish to cut the material. These settings achieved by pulling on the handle (towards the back of the machine), then selecting the desired hole.

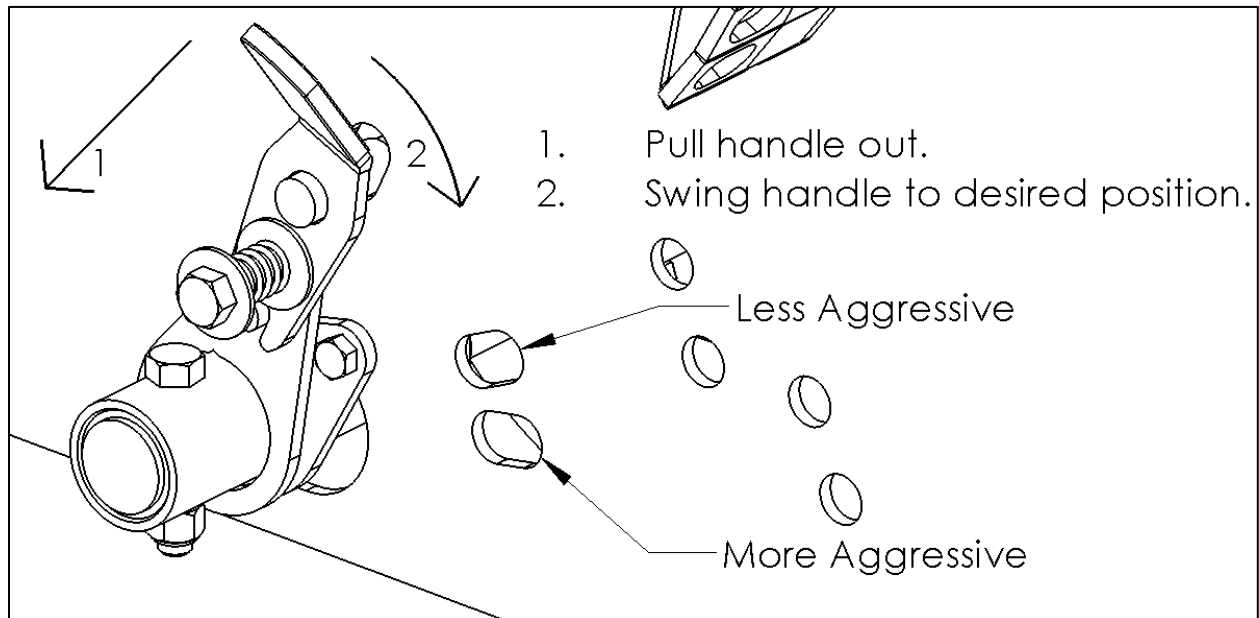

## Optional Total Ration Grain Tank (6300TR)



The Bale King 6300 has an available 40-bushel grain tank, which allows grain to be discharged on top of a windrow of processed hay, or independently out the right side of the machine. This bolt-on kit changes the processor to a 6300TR (Total Ration).

The tank is located on the left side of the machine and features a large opening, 5 ft off the ground for easy filling. A flow control valve allows you to adjust the speed of the augers so that you can meter the grain flow for different situations. It is recommended to determine your desired rate based on driving speed and the flow rate of the tractor. Setting the valve to "0" will give no grain, while setting it to "10" will be full speed.

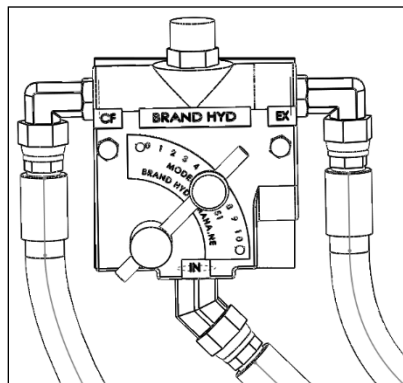

Cleanout doors are located at the bottom end of both the cross-auger, and the grain tank. It is recommended that both be cleaned out at the end of every season.

**Contact Bridgeview for inquiries about adding this kit to an existing machine.**

## SERVICE AND MAINTENANCE

### Greasing Locations

Lubricating the Bale King bale processor should be done on a regular basis.

Every 50 bales			
A	Rotor Gearbox	1	3-5 pumps
Every 150 bales			
B	Bale Fork Pivot	2	3-5 pumps
C	Deck Pivot	2	5 pumps
D	Deck Lift Cylinders	2	3-5 pumps
E	Deck Chain Idler	2	2 pumps
F	Hoop Handle	1	2 pumps
G	PTO Cross & Bearings	4	5 pumps
	PTO Guard Bushings	2	5 pumps
	PTO Spline	1	8-10 pumps
Every 500 bales (or Annually)			
G	PTO CV Joint	1	30 pumps
H	Agitator Bearings *	2	3-5 pumps (DO NOT OVERGREASE)
I	Rotor Bearing *	1	3-5 pumps (DO NOT OVERGREASE)
J	Jack	1	8 - 10 pumps
Annually			
K	Wheel Hubs	4	Pack hubs full

\* DO NOT OVERGREASE BEARINGS. GREASE SHOULD NOT COME THROUGH THE SEALS

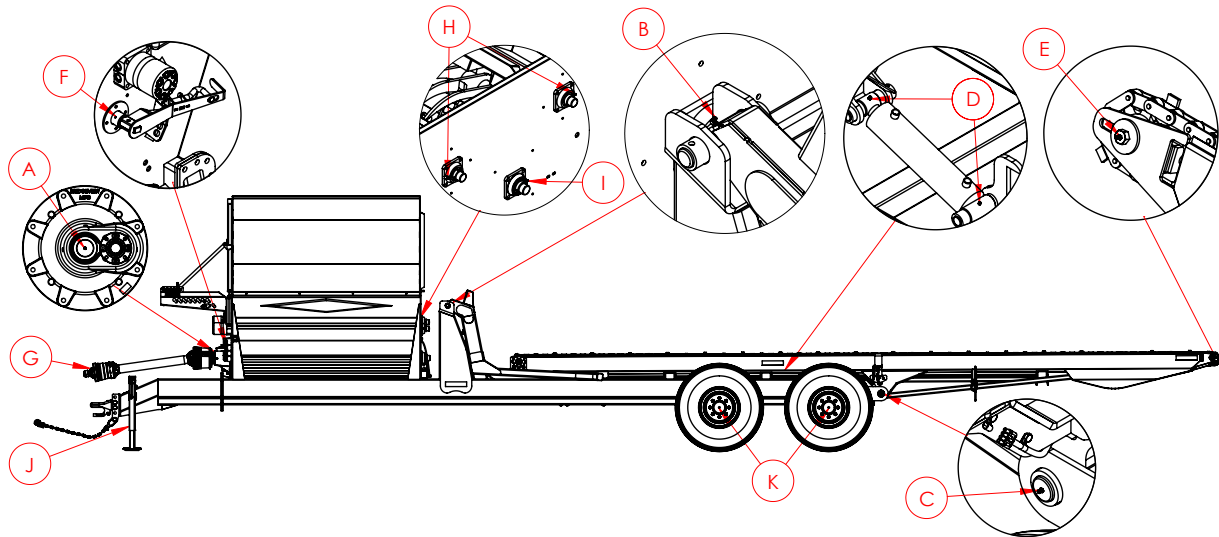

## PTO/Driveline

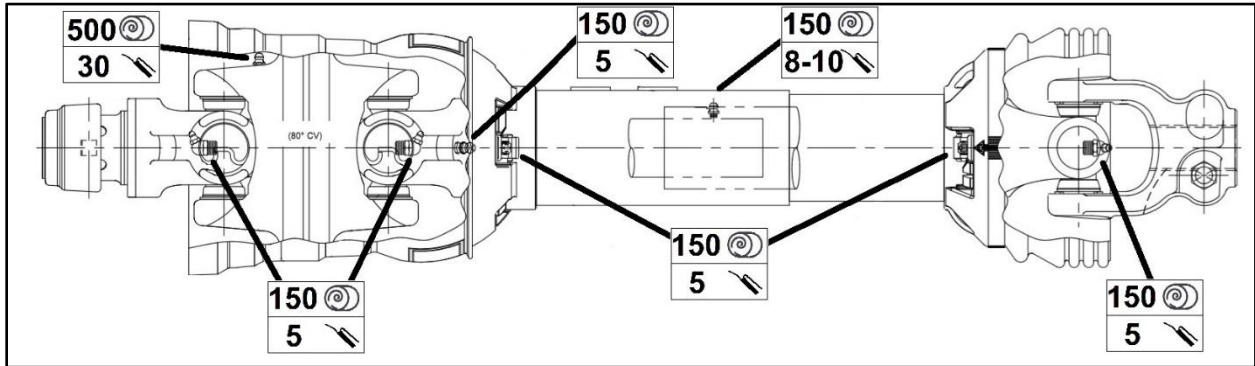

**After storage** for long periods of time, lubricate and check the function of every driveline component before operating. Failure to grease all the joints will **VOID** warranty.

All zerks can be accessed while the PTO is connected to the tractor **EXCEPT** for the telescoping spline, which can only be accessed when the PTO is fully retracted.

Inspect the joints, and ensure that there is no excessive play in the joints.

Inspect the shielding. Make sure that all shields are in place and functioning properly.

## Gearbox

There is one grease zerk on the front of the gear box. Apply 3-5 pumps of good quality grease every 50 bales.

If the gearbox is removed to replace the rotor or perform any other service, add **80 pumps** of grease to the grease zerk upon reinstallation.

The gear box requires GL5 80W90 gear oil. The oil should be filled to the level plug (approximately **500 mL**) and checked on a regular basis. The oil should also be changed at the following intervals:

- 500 bales after first use
- 1000 bales after first use
- Every 5000 bales afterwards, or annually (whichever comes first)

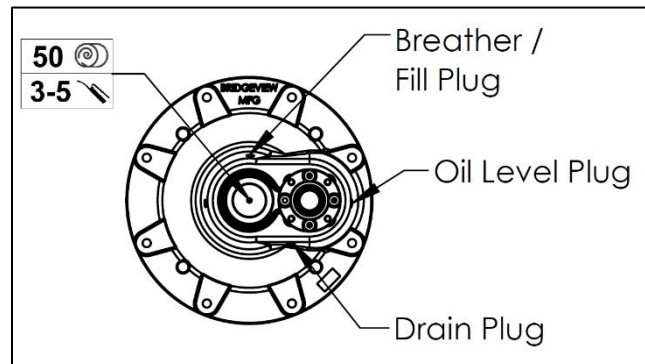



## Hydraulic Maintenance

The hydraulic cylinders are easily removed for repair or maintenance simply by:

- Lowering the fork (or deflector) to the down position and unhooking the hydraulic lines. Be sure there is no pressure on the lines and mark the line locations so there is no confusion when reinstalling the cylinders. Check hydraulic schematics.
- Removing the cotter pin closest to the frame of the machine and removing the cylinder pins.
- To reinstall, reverse the removal procedure

**NOTE:** *Always cover exposed cylinder shafts with grease to avoid rusting of shafts if the unit is not used for extended periods of time. Rusted cylinder shafts are NOT covered by warranty*

The valves should be checked periodically to ensure that they are still functioning correctly. Contaminants in the oil may jam inside the fine ports of the valves and prevent proper function. In this case, the valve may need to be taken apart and cleaned, or replaced entirely.

**NOTE:** *Check all hoses and fittings periodically for leaks. Tighten or replace any dripping components or any worn out hoses.*

## Wheels & Tires

Wheel bearings should be inspected annually for adjustment and lubricated annually. Inspect more often for extensive traveling.

- Lift up each wheel (one at a time) until the wheel spins freely.
- Check for excessive wheel end play by pulling and pushing the tire towards and away from you. Slight end play is acceptable.
- Rotate the tire both directions. It should turn freely and smoothly, with no excessive play, grinding noise, or “sticky” spots.

To repair the wheel bearing:

- Remove the wheel.
- Remove dust cap and the cotter pin which retains the castle nut. Unscrew the castle nut and remove the spindle washer.
- Pull the entire hub (including both bearings and the inside seal) off of the spindle.
- Clean and inspect all parts. Do not contaminate with dirt, etc.
  - If the bearing presents any pitting or corrosion then the bearing must be replaced. The bearing cup inside the hub must be inspected. When replacing bearing, they should be replaced in sets.
  - If the bearing is good, repack it with grease.
  - Whenever the hubs are removed, inspect the seal to ensure that it is not nicked or torn and is still capable of properly sealing the bearing cavity. If there is any question of condition, replace the seal.

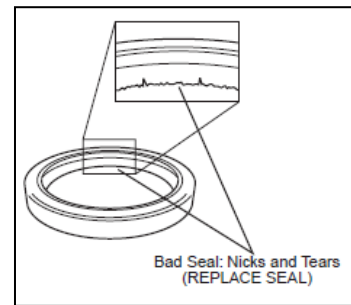

- Reassemble the seal and bearings into the hub, then install back on the spindle. Make sure the bearings and hub cavity are full of grease.
- Install the spindle washer, and the castle nut. Tighten the nut to about 50 ft-lb. Then back the nut off until the wheel will rotate approximately two turns when given a firm spin.
- Align castle nut to closest hole and insert the cotter pin.
- Pack hub full of grease, and spin to check that everything is good.
- Reinstall the dust cap.
- Reinstall the wheels and torque the wheel nuts to 125 ft-lb. This should be rechecked after a day of use to ensure the nuts do not come loose.

Proper tire inflation will help to alleviate puncture problems when towing and operating on rough terrain. Examine the tires for cuts, bruises, cracks, bulges, and penetrations.

Check for proper tire inflation	<b>35 psi</b>
Replace any damaged or worn tires	<b>14Lx16.1SL 12-ply</b>
Check and tighten wheel bolts on a regular basis	<b>125 ft.lb</b>

**Note: Warranty does not cover damaged rims and hubs due to loose wheel bolts or flat tires.**

***Tire warranty is covered by the tire manufacturer.***

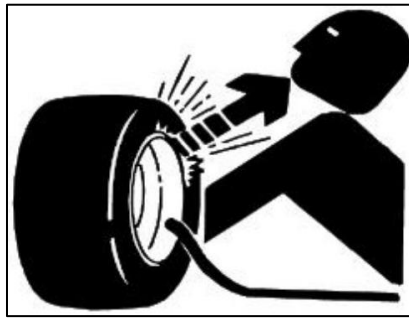

**Note: When inflating tires, use a clip-on chuck and extension hose long enough to allow you to stand to one side and NOT in front of or over the tire assembly.**

## Twine Removal

It is natural that twine from the bales will wrap around the rotor as they are being processed. It is recommended to remove the twine from the rotor every 10-15 bales to avoid having so much that it begins to hinder the flail movement. The more often this is done, the easier it is to remove, since the twine has not had a chance to wrap more tightly. The patented “X” shape makes twine removal much easier.

**WARNING:** Before attempting the removal of twine from the rotor, be sure that the machine is stopped and the tractor is shut **OFF**. Place the tractor in park. Twines can be removed with the use of the optional knife, or any other knife.

An electric device is also available from suppliers to melt the twine & allow it to be pulled off. Once melted, the twine should be removed immediately to prevent damage to the rotor. It is **NOT PERMITTED** to leave the twine burning on the rotor as this has several adverse effects:

- It may take the temper out of the steel, rendering it weaker.
- Loose straw and hay remaining in the machine may ignite causing a fire in the processor.
- Excessive buildup of melted plastic.
- Dry out bushings causing them to wear prematurely.

**NOTE:** *Bridgeview Manufacturing Inc. VOIDS warranty for any damage caused by twine burning in the processor.*



Twine guards are installed on the machine to keep bale twine out of important areas such as bearings.

- The wheel hubs have a twine guard to keep anything from getting tangled in the wheel bearing. Check for and remove any twine which may have wrapped around the spindle.
- The main rotor and the agitators are equipped with removable twine guards. The guards are mounted to inside of the front and rear walls of the machine. The twine guards are bolted and need to be removed if you need to remove or tighten the bolts on the bearings or the hydraulic motors.
- Remove any twine which may have wrapped around the agitators.

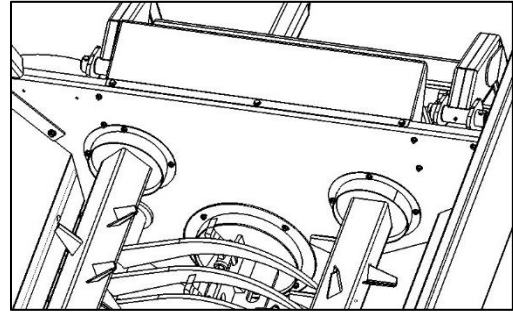

## Feeding Chain

Lubricate the 2 chains with dry graphite every 50 hours of work and before a long period of storage. Rotate the chain so that both sides

### Chain Adjustment Procedure

Check the tension on both chains.

- Locate the middle of the deck.
- Apply 30 lbs of pull on the chain and measure one inch between the chain and the deck.
- Loosen the axles on the idler wheel.
- To tighten the chain, turn the adjustment nut clockwise on the idler wheel until you have the right tension.
- Tighten the nut on the idler wheel.

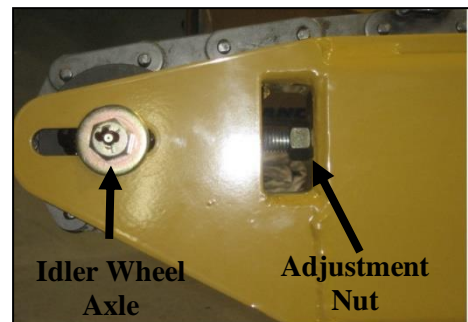

## Gearbox and Flail Replacement Procedure

Flail replacement is accomplished by removing the 3/4”x 4-3/4” bolt holding the flail to the rotor. The flail is then lifted away from the rotor. The bushing can now be removed by using slight pressure to push it out of the flail. Inspect the bolt, bushing, and the flail for wear. If wear is excessive, replace with new parts (see pg. 38).

Bridgeview Manufacturing Inc. recommends when changing flails to change in **PAIRS** (opposite each other). Processing bales with broken flails causes the rotor to be out of balance and excessive vibration may cause machine deterioration.

If a new rotor is required, care must be taken when reinstalling:

- Clean the spline and shaft ends of the rotor of any debris
- Clean the inside of the gearbox. Check the splines for damage.
- Slide rear twine guard over the rotor
- Install new rotor bearing (if necessary). Torque to **200 ft-lb**
- Slide the rotor through the rear bearing. Do not tighten collar yet
- Install the gearbox over the rotor spline and bolt to the tub
- Check flail clearance of **1/2 to 5/8”** to tub panel
- Center the rotor in the tub so that the flails are centered between the hoops and slots
- Tighten bearing lock collar **counter-clockwise**. Apply *loc-tite* to the set screw and torque to **100 in-lb**.
- Check gearbox oil to the side plug level (~500 mL). Replace if necessary.
- Add **80 pumps** of grease to the front gearbox grease zerk.
- Install rear twine guard using 3/8” bolts.

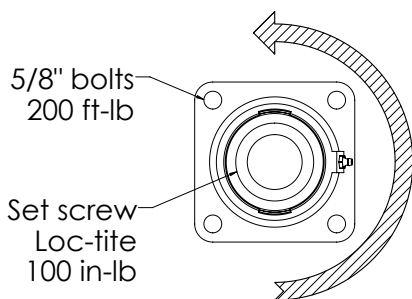
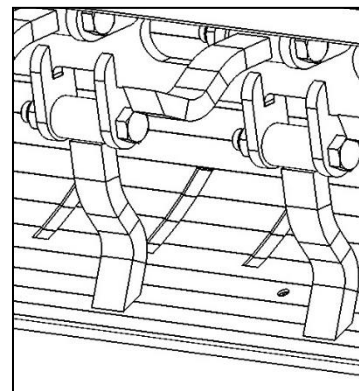

Install Lock Collar

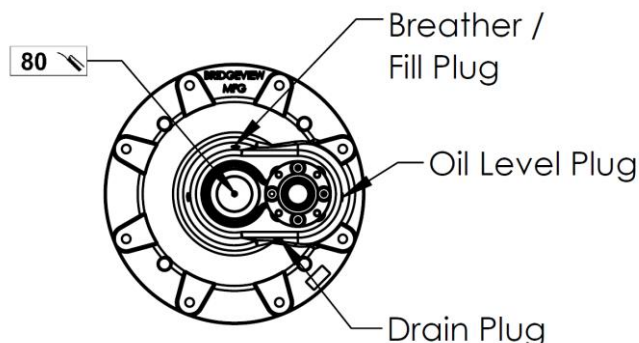



## Trouble-shooting Guide

Problem	Possible Cause	Remedy
<b>Excessive main shear bolt breakage</b>	Engaging PTO at high engine speed or too quickly	<ul style="list-style-type: none"> <li>• Idle tractor to engage PTO then bring up to full operating speed</li> <li>• Feather PTO lever into position</li> </ul>
	Excessive twine wrapped on rotor causing flail movement to be restricted	<ul style="list-style-type: none"> <li>• Cut twine off rotor</li> </ul>
	Broken flails causing rotor to be out of balance	<ul style="list-style-type: none"> <li>• Replace broken flails (in pairs opposite each other)</li> </ul>
	Overloading rotor	<ul style="list-style-type: none"> <li>• Set hoops to less aggressive position</li> <li>• Slow rotation of bale</li> <li>• Change direction of bale rotation</li> </ul>
	Excessive horsepower	<ul style="list-style-type: none"> <li>• Use a smaller tractor</li> </ul>
	Incorrect shear bolt used	<ul style="list-style-type: none"> <li>• Use correct shear bolt</li> </ul>
	Operating machine at less than 1000 PTO RPM	<ul style="list-style-type: none"> <li>• Operate machine at rated 1000 PTO RPM</li> </ul>
<b>Excessive vibration while processing bales</b>	Excessive twine wrapped on rotor causing flail movement to be restricted	<ul style="list-style-type: none"> <li>• Cut twine off rotor</li> </ul>
	Broken flails causing rotor to be out of balance	<ul style="list-style-type: none"> <li>• Replace broken flails (in pairs opposite each other)</li> </ul>
	Overloading rotor	<ul style="list-style-type: none"> <li>• Set hoops to less aggressive position</li> <li>• Slow rotation of bale</li> <li>• Change direction of bale rotation</li> </ul>
	Operating machine at less than 1000 PTO RPM	<ul style="list-style-type: none"> <li>• Operate machine at rated 1000 PTO RPM</li> </ul>
	Rotor bearing failure	<ul style="list-style-type: none"> <li>• Replace failed parts</li> </ul>
<b>Agitators stopping</b>	Excessive loose material in tub causing agitator to jam	<ul style="list-style-type: none"> <li>• Reverse direction of bale rotation</li> <li>• Turn bale more slowly</li> </ul>
	Tractor relief pressure set too low	<ul style="list-style-type: none"> <li>• Set tractor relief pressure to at least 2500 PSI</li> </ul>
<b>A single agitator stopping</b>	Mechanical flow divider valve not functioning correctly	<ul style="list-style-type: none"> <li>• Contact your dealer for repairs</li> </ul>
	Coupler between motor and agitator broken	<ul style="list-style-type: none"> <li>• Replace failed parts</li> </ul>
<b>No grain flow</b>	Flow control valve set too low	<ul style="list-style-type: none"> <li>• Increase flow rate in tractor or on flow control valve</li> </ul>
<b>Flow control valve going over relief</b>	Flow control valve relief pressure set too low	<ul style="list-style-type: none"> <li>• Use hydraulic pressure gauge to ensure relief pressure is set to 2200psi.</li> </ul>
	Auger chute at too shallow of an angle for grain to clear fast enough	<ul style="list-style-type: none"> <li>• Run auger slower</li> <li>• Run chute at steeper angle</li> </ul>
<b>A single chain stopping</b>	Mechanical flow divider valve not functioning correctly	<ul style="list-style-type: none"> <li>• Contact dealer for repairs</li> </ul>
	Sprocket is broken, or motor shaft has failed	<ul style="list-style-type: none"> <li>• Replace failed components</li> </ul>
	Chain has slipped off the sprocket	<ul style="list-style-type: none"> <li>• Reinstall chain and check tension (pg. 28)</li> </ul>

<b>Deflector or tilt functions do not work</b>	Control box is not plugged in	• Plug in the control box. Needs power from the tractor.
	Control box is not connected	• Plug the control box to the 4-pin plug on the processor
	Control box fuse has failed	• Replace the fuse

### Features and Specifications

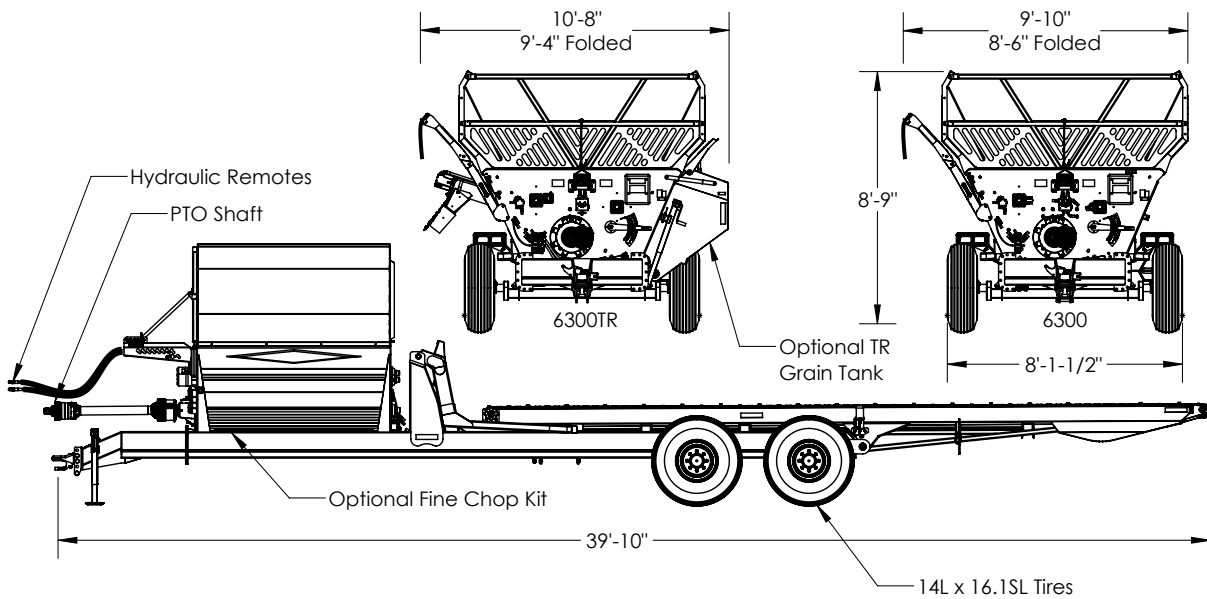

<b>Dimensions:</b>	<b>6300</b>	<b>6300TR</b>
Overall Weight	9060 lb	9700 lb
Drawbar Weight	3100 lb	3400 lb
Overall Width (Deflector Down)	11'-4"	12'-3"
Grain Tank Capacity		40 bushels
Rotor Extended Tip Diameter		27 in.
Discharge Opening		12 x 80 in.

<b>Wheels:</b>	
Tire Size	14L x 16.1SL 12-ply
Tire Inflation	35 psi
Wheel Nut Torque	125 ft-lb

**Driveline:**

Minimum Horsepower	100 HP
	*Ensure sufficient horsepower for terrain driven.
PTO Shaft	Weasler: Cat. 6 80 deg. C.V.
Shear Bolt	3/8 x 2" Fine Thread Gr. 5
Rated PTO RPM	1000 RPM
Flail Tip Speed at 1000 RPM	7000 FPM
Number of Flails	28
Flail Size	3/4 x 1-1/2 x 7 in.
Flail Bushing	Oil Impregnated Brass
Rotor Shaft	1-15/16" Bearing
Gearbox Oil	GL5 80W90
Gearbox Oil Capacity	500 mL

**Hydraulics:**

Required Remotes	3 Standard (with Diverter)
Minimum Flow Requirements	15 GPM
Minimum Pressure Requirements	1800 psi

**Other:**

Agitator Shaft	1-3/4" Bearings
Twine Guards	Rotor, Agitators, Axles
Adjustable Bale Fork Width (on centers)	48 in. or 40.5 in.
Adjustable Hitch Height	4 settings at 1.5 in. intervals (13" -17.5")
Discharge deflector	Adjustable top and bottom Removable rubber end flap

## PARTS MANUAL

Machine Overview .....	34
Jack & Hitch .....	35
Wheels & Hub.....	36
Spindle .....	37
Rotor & Drive Components.....	38
Gearbox.....	39
PTO Shaft .....	41
Grates.....	42
Agitators .....	44
Deflector & Hose Cover.....	45
Top Tub Components.....	47
Rear Forks.....	48
Front Tub Components.....	49
Hose Holder .....	50
Rear Tub and Hydraulic Components.....	51
Bale Deck .....	52
Chain Motor Assembly.....	53
Idler Sprocket Assembly.....	54
Lights and SMV Sign .....	55
Decals .....	57
Total Ration Grain Tank Option.....	59
Total Ration Tank Front .....	60
Total Ration Tank Rear .....	62
Total Ration Cross Auger .....	64
Total Ration Tank Lid .....	66
Fine Chop Option.....	67
Twine Cutter Option.....	69
Diverter Control Box.....	70
Hydraulic Schematics.....	75

## Machine Overview

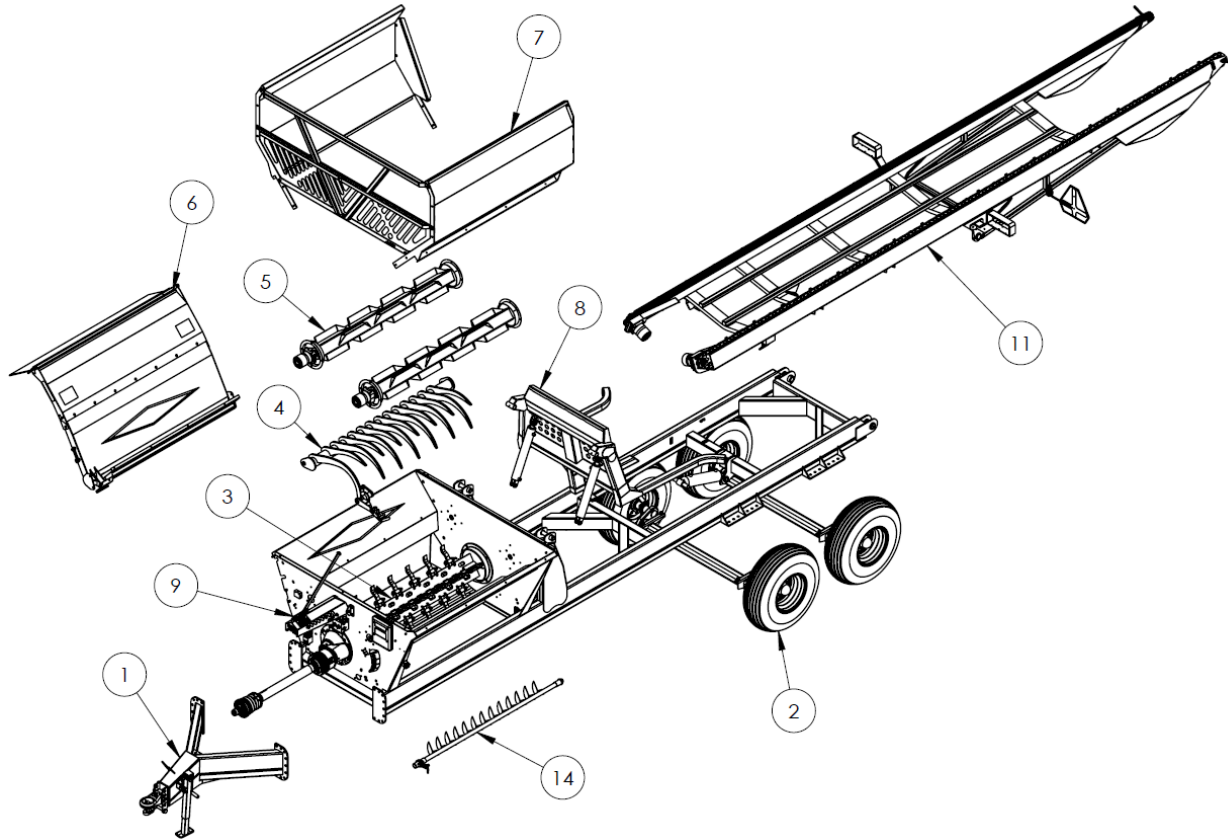

1	Jack & Hitch	Page 35	10	Rear Tub Components	Page 51
2	Wheels & Hub	Page 36	11	Bale Deck	Page 52
3	Rotor & Drive Components	Page 38	12	Decals	Page 57
4	Grates	Page 42	13	Total Ration Grain Tank Option	Page 59
5	Agitators	Page 44	14	Fine Chop Option	Page 67
6	Deflector & Hose Cover	Page 45	15	Twine Cutter Option	Page 69
7	Top Tub Components	Page 47	16	Diverter Control Box	Page 70
8	Rear Forks	Page 48	17	Hydraulic Schematics	Page 75
9	Front Tub Components	Page 49			

**\*\* CHECK YOUR SERIAL NUMBER BEFORE ORDERING PARTS \*\***  
**\*\* PAY ATTENTION TO SERIAL NUMBER SPLITS WHERE INDICATED \*\***  
**\*\* LEFT / RIGHT AS DESCRIBED ARE VIEWED FROM THE REAR \*\***

Per Quantities: A/R = As Required  
 Per ID#: NSS = Not Sold Separately



## Jack & Hitch

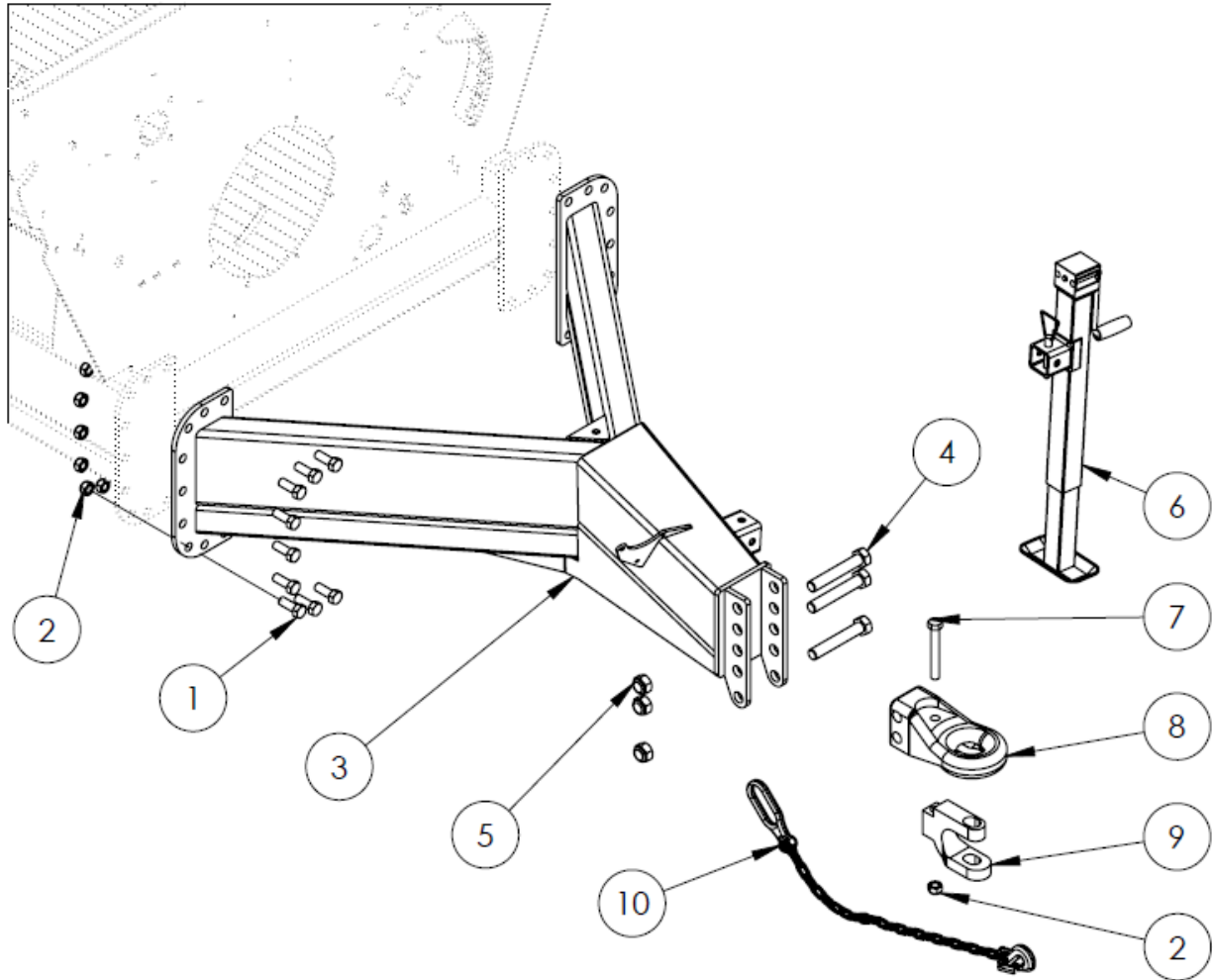

#	DESCRIPTION	PART #	QTY
1	Bolt, 3/4 x 2"	13800	18
2	Nut, 3/4" Stover Lock	11823	18
3	Hitch Frame	35562	1
4	Bolt, 1 x 6"	21728	3
5	Nut, 1" Stover Lock	21746	2
6	Jack, 7000 lb	35250	1
	Comes with pin		
7	Bolt, 3/4 x 5-1/2"	26406	1
8	Hitch Tongue	23404	1
9	Hitch Clevis Kit	25540	1
	Includes 2 & 7		
10	Safety Chain, 21000lb x 52"	23559	1

## Wheels & Hub

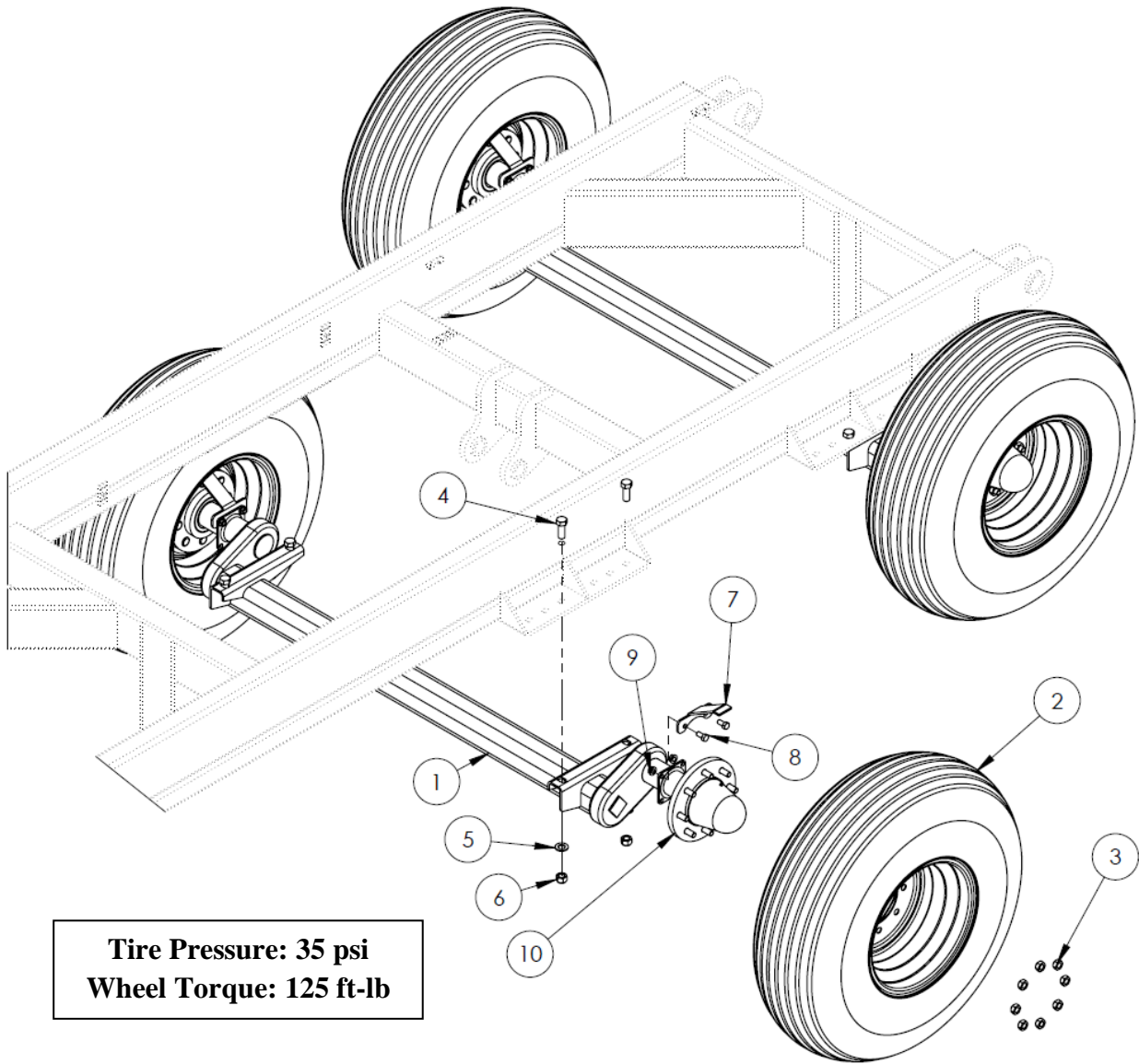

**Tire Pressure: 35 psi**  
**Wheel Torque: 125 ft-lb**

#	DESCRIPTION	PART #	QTY
1	Torflex Axle, 8000#	22850	2
2	Tire & Rim, 14L-16.1SL (12 Ply) See your local tire dealer	NSS	4
3	Wheel Nut	23183	32
4	Bolt, 3/4 x 2"	13800	8
5	Washer, 3/4" Flat	13717	8
6	Nut, 3/4" Stover Lock	11823	8
7	Twine Guard	23744	4
8	Bolt, 1/2" x 1-1/4"	10240	8
9	Nut, 1/2" Serrated Flange	10273	8
10	Hub Assembly See breakdown next page		

### Spindle

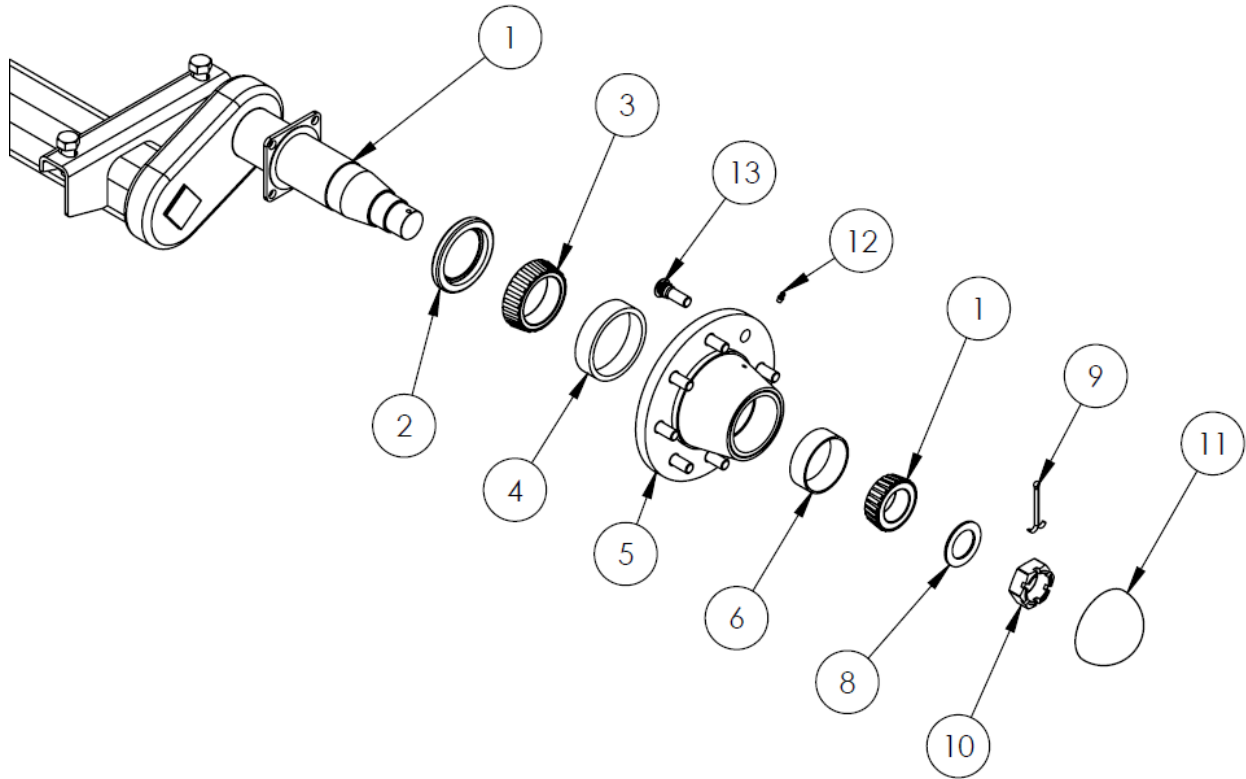

#	DESCRIPTION	PART #	QTY	
1	Complete Torflex Axle Assembly	22850	1	
2	Seal	23569	1	
3	Inner Bearing	JLM506849	23567	1
4	Inner Bearing Race	JLM506810	23571	1
5	Hub Housing	Includes 4,6,12 & 13	23572	1
6	Outer Bearing Race	LM501310	23570	1
7	Outer Bearing	JLM501349	23568	1
8	Spindle Washer		23564	1
9	Cotter Pin, 5/32 x 2"		23565	1
10	Castle Nut		23566	1
11	Dust Cap		23563	1
12	Grease Zerk		10270	1
13	Wheel Stud		23573	8

**NOTE: Quantity is per hub**

## Rotor & Drive Components

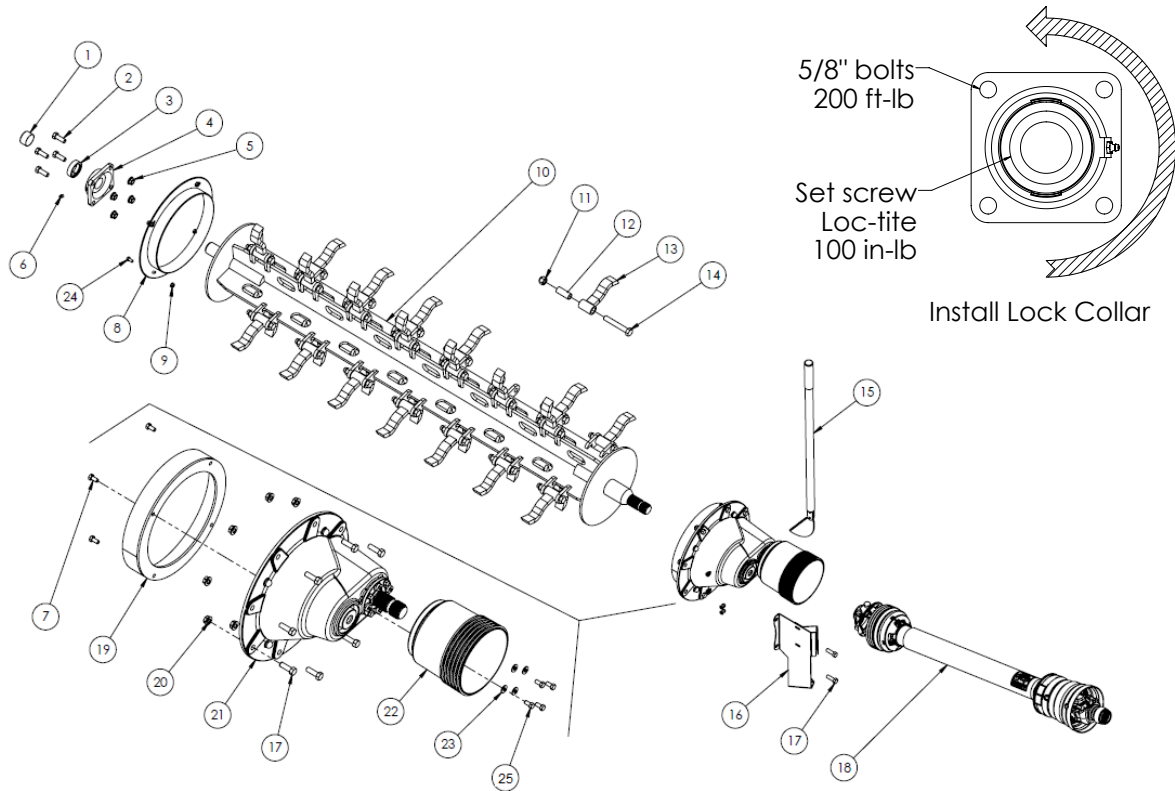

#	DESCRIPTION	PART #	QTY	
1	Rotor Shaft Cap	17380	1	
2	Bolt, 5/8" x 1-3/4" NF Gr. 8	10274	4	
3	Lock Collar	10268	1	
4	Rotor Bearing	Includes # 3 & 6	10221	1
5	Nut, 5/8" NF Serrated Flange Gr. 8	15398	4	
6	Grease Zerk, 1/8" NPT Straight	10270	1	
7	Bolt, 3/8" x 3/4"	11816	4	
8	Rotor Twine Guard, Rear	22413	1	
9	Nut, 3/8" Serrated Flange	10271	4	
10	X-Rotor Weldment	22449	1	
11	Nut, 3/4" Stover Lock	11823	28	
12	Brass Flail Bushing	10005	28	
13	Rotor Flail	<b>REPLACE IN PAIRS</b>	22412	28
14	Bolt, 3/4" x 4-3/4"	10443	28	
15	OPTIONAL Twine Cutter	See Breakdown	-	
16	OPTIONAL Twine Cutter Holder	See Breakdown	-	
17	Bolt, 1/2" x 1-1/2"	10174	8	
18	PTO Shaft	See Breakdown	-	1
19	Gearbox Twine Guard	23002	1	
20	Nut, 1/2" Stover Lock	20154	8	
21	Gearbox Assembly	See Breakdown	-	1
22	PTO Safety Shield	34899	1	
23	Flat Washer, 3/8"	11667	4	
24	Bolt, 3/8 x 1"	13806	4	
25	Bolt, M10 x 16	25154	4	

# Gearbox

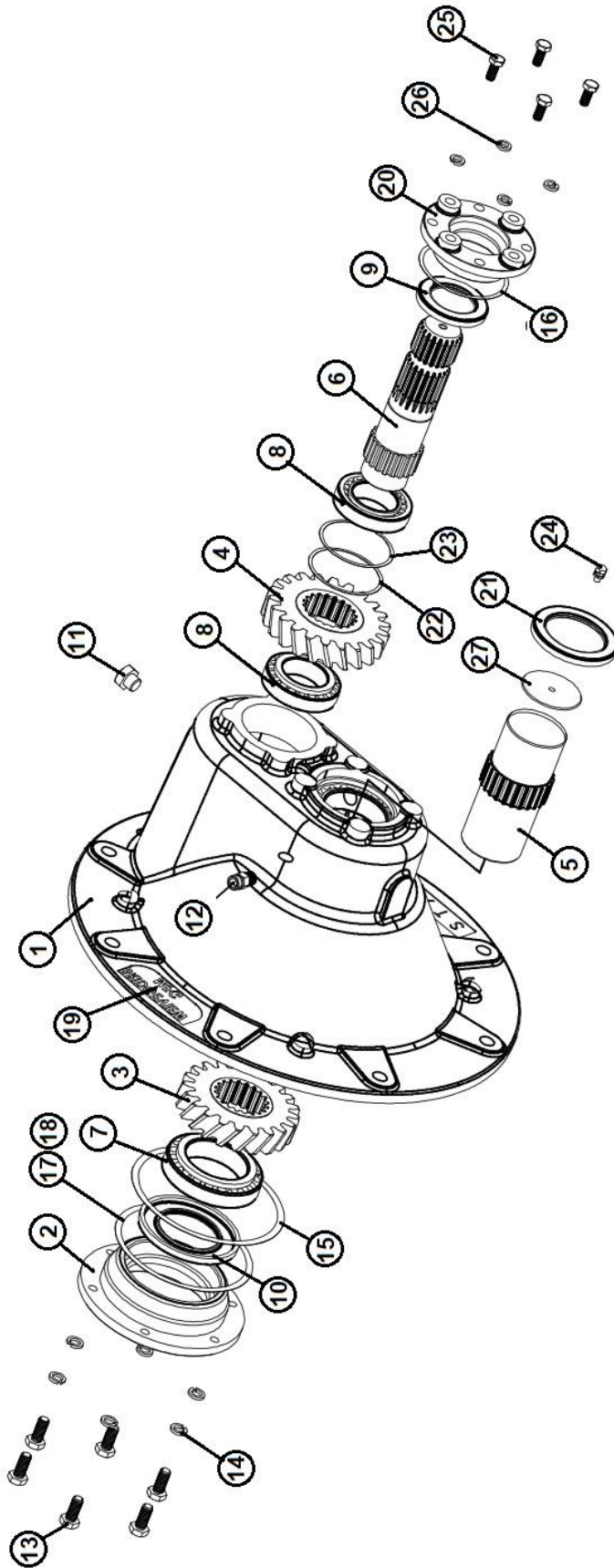



**Gearbox**

#	DESCRIPTION	PART #	QTY
	Complete Gearbox Assembly	22158	1
<b>1</b>	Housing	-	1
<b>2</b>	End Cap	-	1
<b>3</b>	Output Gear	-	1
<b>4</b>	Input Gear	-	1
<b>5</b>	Output Shaft	-	1
<b>6</b>	Input Shaft	-	1
<b>7</b>	Bearing (32012) 60mm	10496	2
<b>8</b>	Bearing (32009) 45mm	10497	2
<b>9</b>	Seal, 45 x 60 x 8	24013	1
<b>10</b>	Seal, 60 x 100 x 10	10498	1
<b>11</b>	Pipe Plug, 3/8" NPT	24014	2
<b>12</b>	Relief Plug, 3/8" NPT	24015	1
<b>13</b>	Bolt, M8 x 25 Gr. 8.8	24026	6
<b>14</b>	Lock Washer, M8	24016	6
<b>15</b>	O-Ring	24017	1
<b>16</b>	O-Ring	24018	1
<b>17</b>	Shim, 125 x 164 x 0.1	24022	2
<b>18</b>	Shim, 125 x 164 x 0.3	24023	2
<b>19</b>	Name Plate (Bridgeview)	-	1
<b>20</b>	End Cap	-	1
<b>21</b>	Seal, 60 x 85 x 10	10500	1
<b>22</b>	Shim, 68 x 74.5 x 0.1	24024	2
<b>23</b>	Shim, 68 x 74.5 x 0.3	24025	2
<b>24</b>	Grease Zerk, 1/4"-28 Straight	26219	1
<b>25</b>	Bolt, M10 x 25	15087	4
<b>26</b>	Lock Washer, M10	24021	4
<b>27</b>	Press Cup	24446	1

**NOTE:** Items with no part number are not sold separately. A complete gearbox is required.

### PTO Shaft

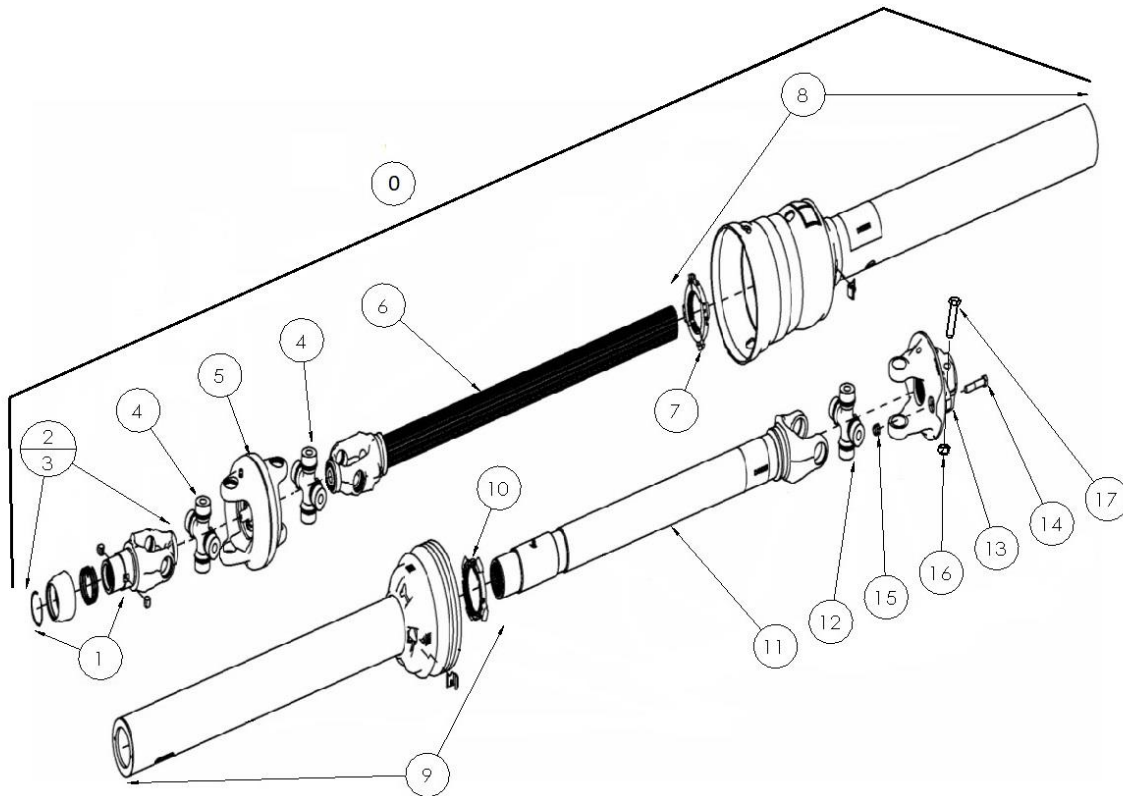

#	DESCRIPTION	PART #	QTY
	Complete PTO Shaft Assembly (1-3/8")	20546	1
<b>0a</b>	Tractor Half PTO Assembly (1-3/8"-21 Spline)	32505	1
<b>0b</b>	Tractor Half PTO Assembly (1-3/4"-20 Spline)	32506	1
<b>1a</b>	Safety Slide Lock Repair Kit (1-3/8"-21 Spline)	17567	1
<b>1b</b>	Safety Slide Lock Repair Kit (1-3/4"-20 Spline)	24981	1
<b>2</b>	WWCV Auto-Lok Yoke Assembly (1-3/8"-21 Spline)	20549	1
<b>3</b>	WWCV Auto-Lok Yoke Assembly (1-3/4"-20 Spline)	20556	
<b>4</b>	CV Cross and Bearing Kit (Equal Length)	20550	2
<b>5</b>	CV Center Housing	20551	1
<b>6</b>	Yoke & Shaft Assembly Tractor Side	20552	1
<b>7</b>	Guard Repair Kit Tractor Side	20553	1
<b>8</b>	Guard Assembly Tractor Side	17583	1
<b>9</b>	Guard Assembly Implement Side	17585	1
<b>10</b>	Guard Repair Kit Implement Side	17572	1
<b>11</b>	Yoke & Tube Assembly Implement Side	17584	1
<b>12</b>	U-joint Cross & Bearing Kit	17573	1
<b>13</b>	Shear Assembly * Does not come with bolts 14 or 17 *	29963	1
<b>14</b>	Shear Bolt, 3/8" x 2" Fine Thread	33285	1
<b>15</b>	Nut, 3/8" Fine Thread Stover Lock	33286	1
<b>16</b>	Nut, 5/8" Stover Lock	24982	2
<b>17</b>	Bolt, 5/8" x 3-1/2"	24983	2

**NOTE:** Ensure that the PTO shaft on the machine is correct to the drawings below. Equal length CV cross (4.19") with bearing cup diameter 1.38". If the damaged PTO has different dimensions, consult the Bridgeview Manufacturing website.

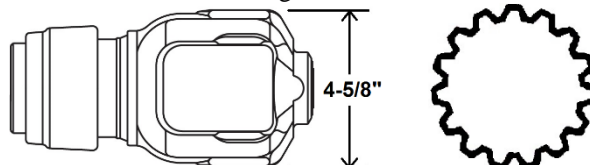

## Grates

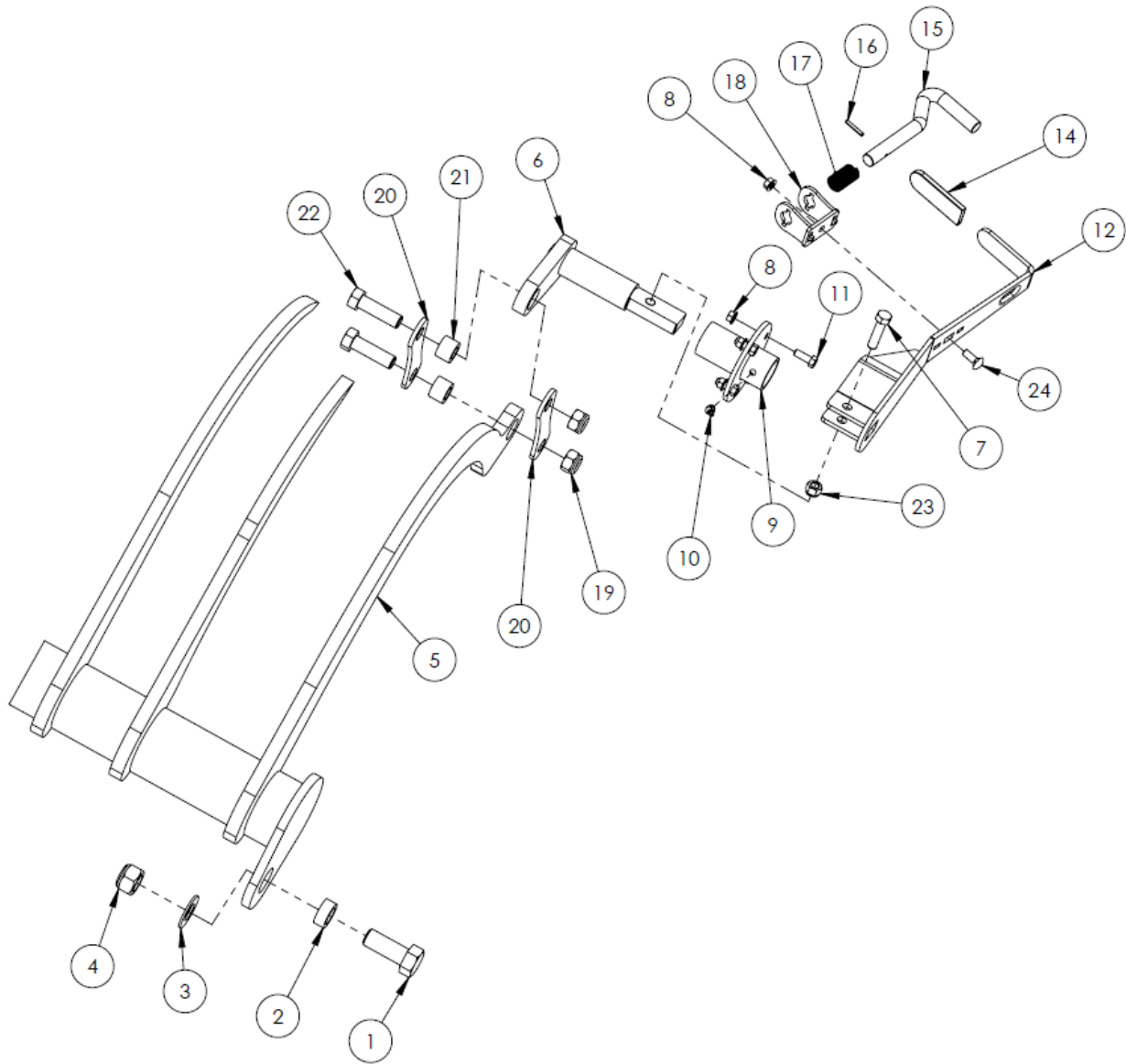

**Grates**

#	DESCRIPTION	PART #	QTY	
1	Bolt, 1" x 2-1/2"	21820	2	
2	Grate Pivot Bushing	22417	2	
3	Flat Washer, 1"	14472	2	
4	Nut, 1" Stover Lock	21746	2	
5	Grate Assembly	29944	1	
6	Grate Adjustment Cam	31720	1	
7	Bolt, 1/2" x 2"	10322	1	
8	Nut, 3/8" Serrated Flange	10271	5	
9	Grate Handle Pivot	Comes with grease zerk	31715	1
10	Grease Zerk, 1/4"-28 x 45°	20888	1	
11	Bolt, 3/8" x 1"	13806	4	
12	Grate Handle	Comes with #18,24,8	31725	1
13	Washer, 3/8" Flat	11667	-	
14	Rubber Cover	10297	1	
15	S-Handle	22187	1	
16	Roll Pin, 3/16" x 1-1/4"	10302	1	
17	Grate Handle Spring	10301	1	
18	Handle Spring Guide	33693	1	
19	Nut, 3/4" Nylon Lock	10007	2	
20	Grate Shackle	31709	2	
21	Grate Shackle Bushing	22415	2	
22	Bolt, 3/4" x 2-1/2"	14470	2	
23	Nut, 1/2" Nylon Lock	10241	1	
24	Bolt, 3/8 x 1" Carriage	15718	1	

## Agitators

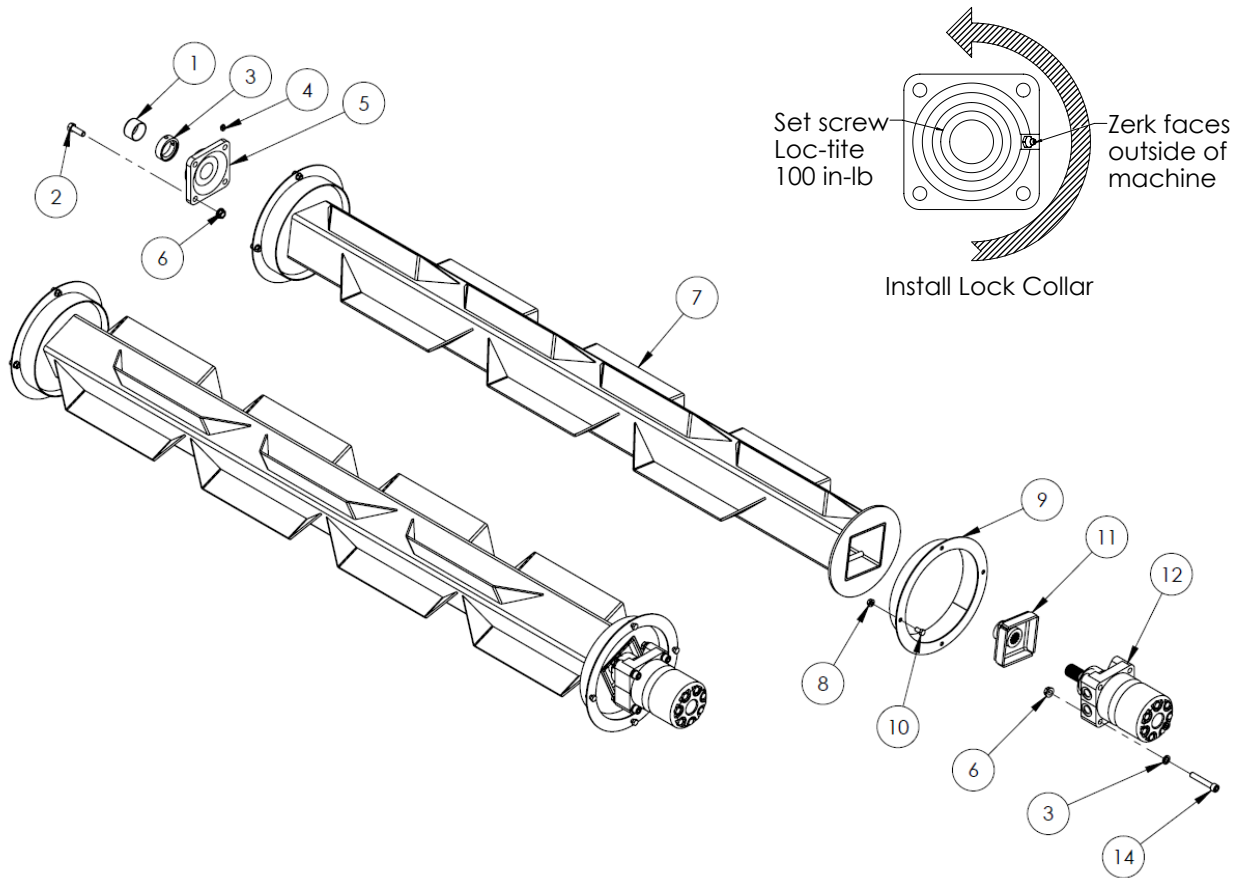

#	DESCRIPTION	PART #	QTY	
1	Agitator Shaft Cap	17381	2	
2	Bolt, 1/2" x 1-1/2"	10174	8	
3	Lock Collar	10040	2	
4	Grease Zerk, 1/8" NPT Straight	10270	2	
5	Agitator Bearing	Includes # 3 & 4	10038	2
6	Nut, 1/2" Serrated Flange	10273	16	
7	Agitator	31596	2	
8	Nut, 3/8" Serrated Flange	10271	16	
9	Agitator Twine Guard	22419	4	
10	Bolt, 3/8" x 3/4"	11816	16	
11	Agitator Insert	22084	2	
12	Agitator Motor, 8" Long Seal Kit	25872 25891	2	
13	Lock Washer, 1/2"	14447	8	
14	Socket Head Bolt, 1/2" x 3"	25952	8	

### Deflector & Hose Cover

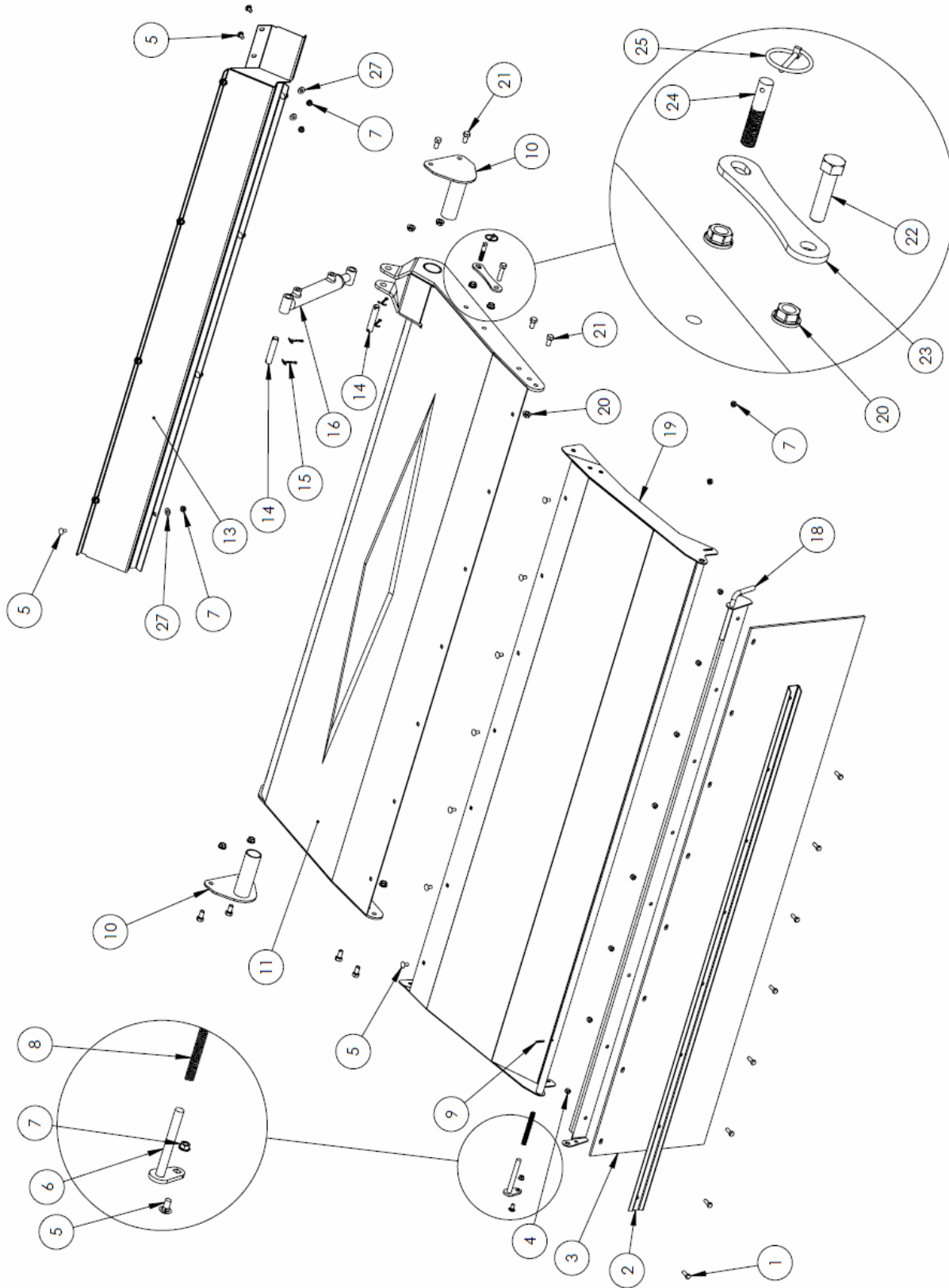



**Deflector & Hose Cover**

#	DESCRIPTION	PART #	QTY
1	Bolt, 3/8" x 1"	13806	8
2	Deflector Rubber Channel	22423	1
3	Deflector Rubber	10477	1
4	Nut, 3/8" Nylon Lock	10806	8
5	Carriage Bolt, 3/8" x 3/4"	14072	18
6	Deflector Flipper Pin	24464	1
7	Nut, 3/8" Serrated Flange	10271	18
8	Compression Spring	24461	1
9	Roll Pin, 3/16" x 1-1/4"	10302	1
10	Deflector Pivot	22426	2
11	Inner Deflector	32196	1
13	Hose Cover	32191	1
14	Cylinder Pin, 3/4" x 3" Usable	22007	2
15	Cotter Pin, 3/16" x 1-1/4"	11669	4
16	Hydraulic Cylinder, 1-1/2" x 6" x 1" Seal Kit	21711 23738	1
18	Deflector Rubber Flipper	24463	1
19	Outer Deflector	31754	1
20	Nut, 1/2" Serrated Flange	10273	12
21	Bolt, 1/2" x 1"	10824	8
22	Bolt, 1/2" x 2"	10322	1
23	Deflector Lock	22422	1
24	Pin Stud	13231	1
25	Lynch Pin	13233	1
27	Flat Washer, 3/8"	11667	10

## Top Tub Components

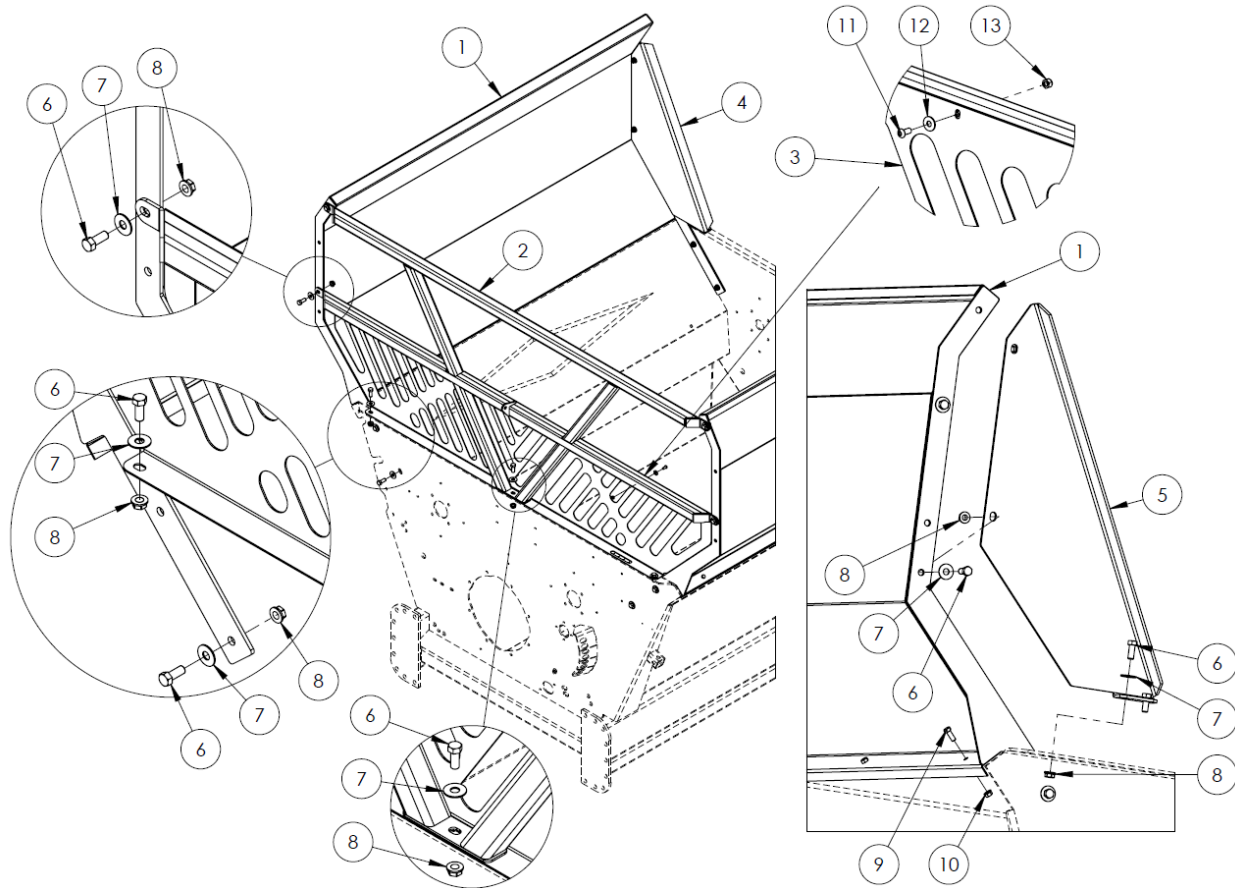

#	DESCRIPTION	PART #	QTY
1	Wing	31692	2
2	Front Rack	31730	1
3	Front Rack Grating	32479	1
4	Wing Bolt-on Bracket (Right)	22431	1
5	Wing Bolt-on Bracket (Left)	22430	1
6	Bolt, 1/2" x 1 1/4"	10240	23
7	Washer, 1/2" Flat	11668	23
8	Nut, 1/2" Serrated Flange	10273	23
9	Bolt, 3/8 x 1"	13806	8
10	Nut, 3/8" Serrated Flange	10271	8
11	Bolt, 5/16" x 3/4" Button Head	32513	8
12	Washer, 5/16" Flat	12496	8
13	Nut, 5/16" Nylon Lock	11815	8

## Rear Forks

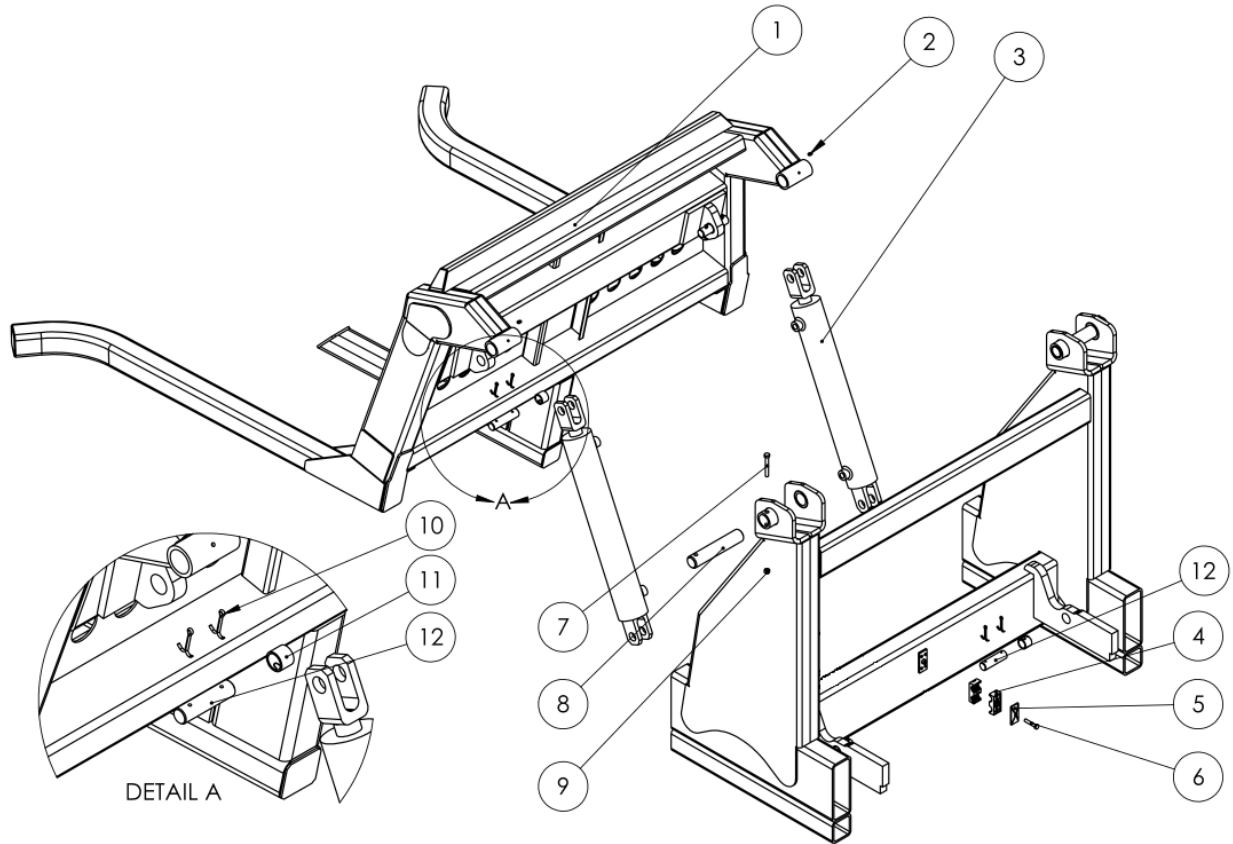

#	DESCRIPTION	PART #	QTY
1	Back Fork	30504	1
2	Grease Zerk 1/4" x 90°	16389	2
3	Hydraulic Cylinder (3 x 18 x 1.5) Seal Kit	21717 20807	2
4	Hydraulic Hose Clamp 1/2"	21561	14
5	Hose Clamp Top 1/2"	21725	7
6	5/16" x 1-3/4" Bolt	21726	7
7	3/8" x 2-3/4" Bolt	20908	2
8	Fork Pivot Pin	22006	2
9	Nut, 3/8" Nylon Lock	10806	2
10	Cotter Pin (3/16" x 1-1/2")	10072	8
11	Spring Bushing (1" Pin)	23708	4
12	Cylinder Pin (1" x 3-1/2")	10339	4

## Front Tub Components

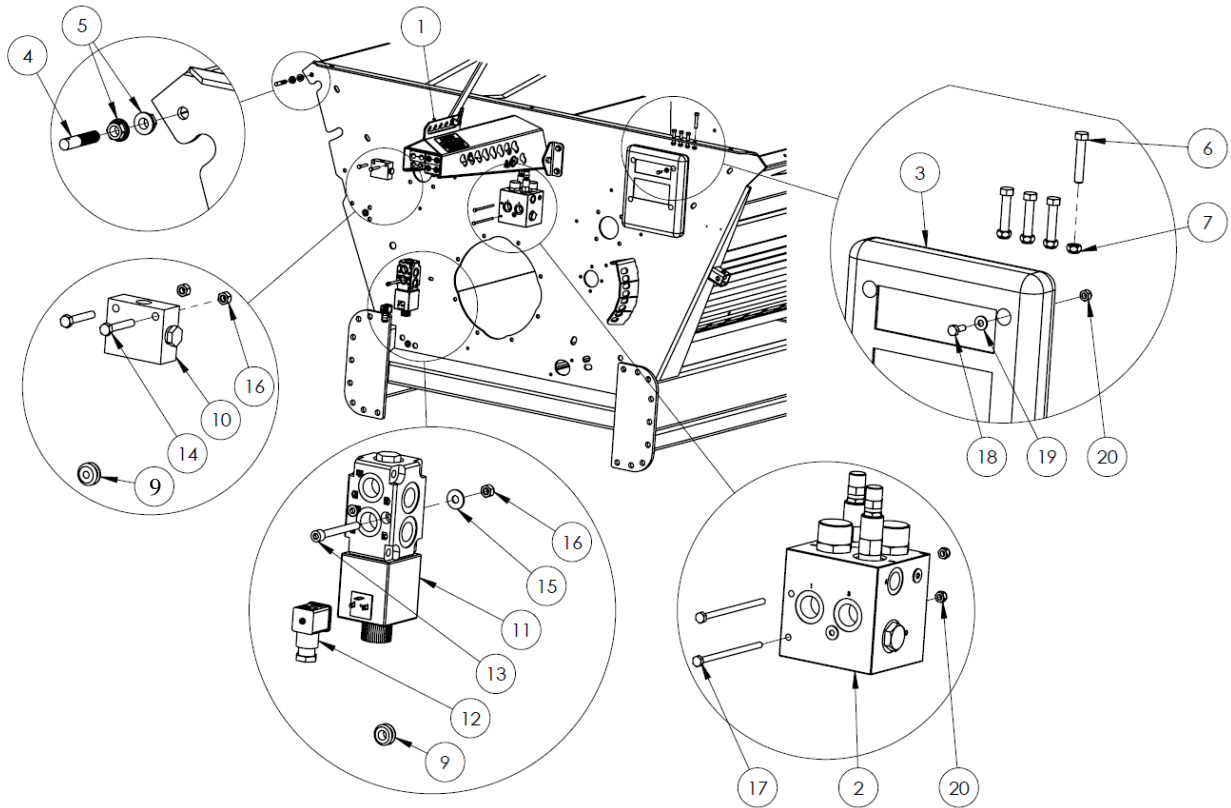

#	DESCRIPTION	PART #	QTY
1	Hose Holder See page 50	-	-
2	Flow Divider Valve	25778	1
3	Operator Manual Holder	22409	1
4	Threaded Pin	13231	1
5	Nut, 1/2" Serrated Flange	10273	2
6	Bolt, 3/8 x 2" Fine Thread Gr.5 PTO Shear Bolt	33285	4
7	Nut, 3/8" Fine Thread Stover Lock PTO Shear Bolt	33286	4
8	Grommet, 5/16 x 1/4" Thick	13179	1
9	Grommet, 7/16" x 1/4" Thick	21428	1
10	Pilot Check Valve	19114	1
11	Diverter Valve # Nut & O-Ring Kit Magnet Kit	11743 17977 11798	1
12	Valve Plug	13657	1
13	Bolt, 5/16 x 3" Socket Head	11783	2
14	Bolt, 5/16 x 2"	15572	2
15	Washer, 5/16" Flat	12496	2
16	Nut, 5/16" Nylon Lock	11815	4
17	Bolt, 1/4 x 5"	25951	2
18	Bolt, 1/4 x 3/4"	11809	4
19	Washer, 1/4" Flat	11666	4
20	Nut, 1/4" Nylon Lock	11664	6

# NOTE: See page 70 for information on the control box

## Hose Holder

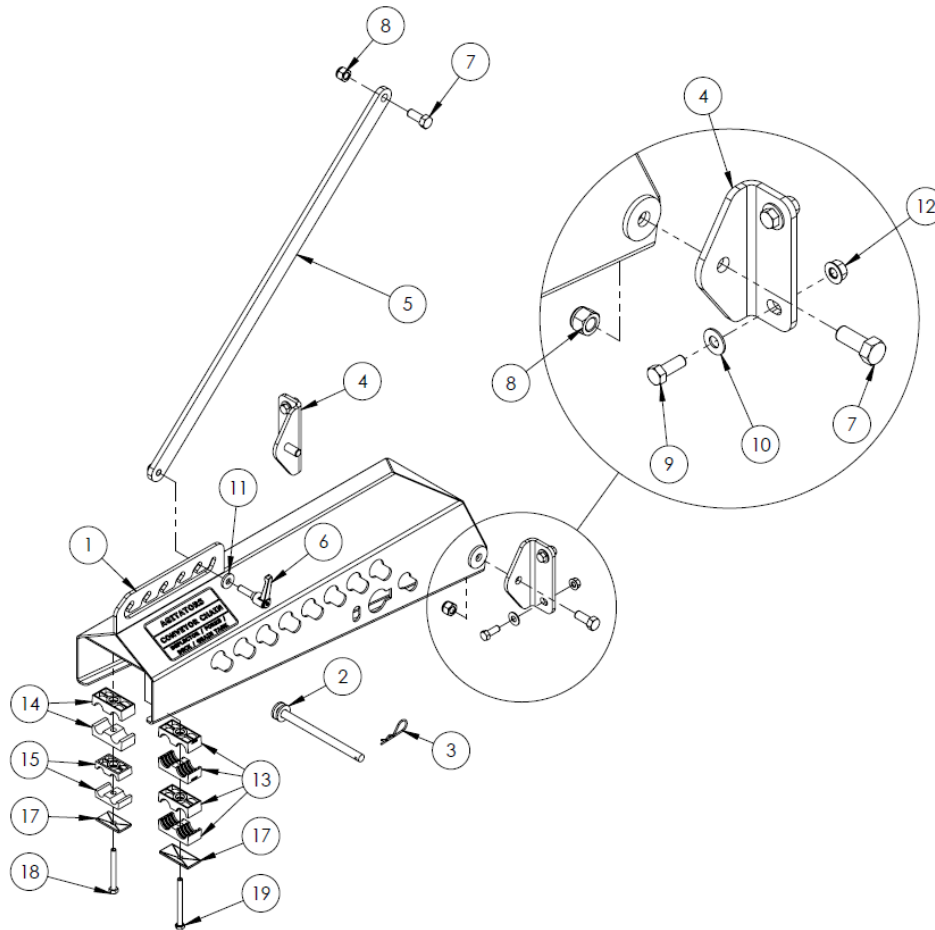

#	DESCRIPTION	PART #	QTY
1	Adjustable Hose Holder	35038	1
2	Hose Holder Pin	31745	1
3	Hairpin, 3/32 x 5/8"	11786	1
4	Hose Holder Pivot Bracket	35041	2
5	Hose Holder Linkage	35040	1
6	Threaded Adjustable Handle	34944	1
7	Bolt, 1/2 x 1-1/4"	10240	3
8	Nut, 1/2" Nylon Lock	10241	3
9	Bolt, 3/8" x 1"	13806	4
10	Flat Washer, 3/8"	11667	4
11	Flat Washer, 3/8" Heavy	33189	1
12	Nut, 3/8" Serrated Flange	10271	4
13	Hydraulic Hose Clamp, 1/2"	21561	4
14	Hydraulic Hose Clamp, 3/8"	22180	2
15	Hydraulic Hose Clamp, 1/4"	22181	2
16	Hydraulic Hose Clamp Cap, Large	21725	1
17	Hydraulic Hose Clamp Cap, Small	22182	1
18	Bolt, 5/16" x 3"	22844	1
19	Bolt, 5/16" x 3-1/2"	13765	1

## Rear Tub and Hydraulic Components

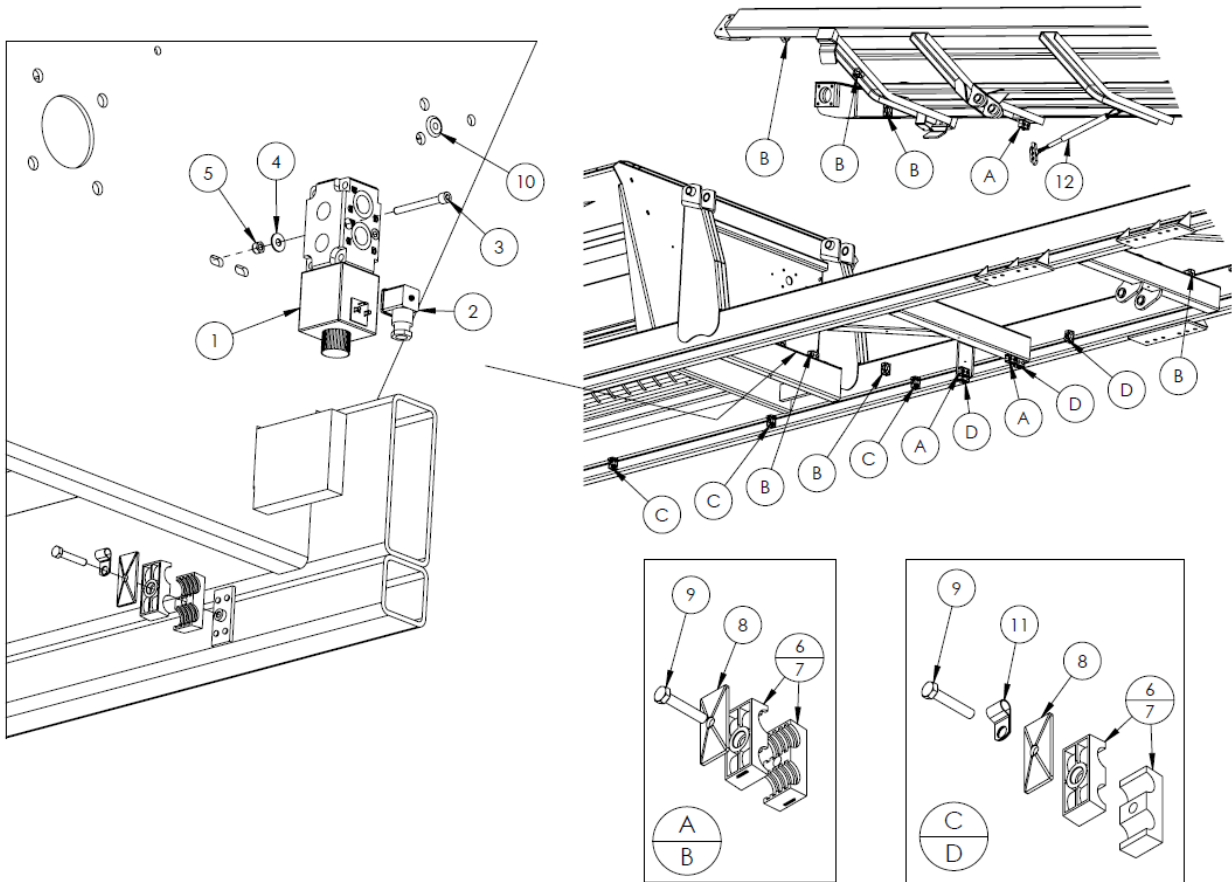

#	DESCRIPTION	PART #	QTY
1	Diverter Valve #	11743	1
	Nut & O-Ring Kit	17977	
	Magnet Kit	11798	
2	Diverter Valve Plug	13657	1
3	Bolt, 5/16 x 3" Socket Head	11783	2
4	Washer, 5/16" Flat	12496	2
5	Nut, 5/16" Nylon Lock	11815	2
6	Hydraulic Hose Clamp, 1/2"	21561	4
7	Hydraulic Hose Clamp, 3/8"	22180	2
8	Hydraulic Hose Clamp Cap, Large	21725	1
9	Bolt, 5/16" x 1-3/4"	21726	1
10	Grommet, 7/16 x 1/4" Thick	21428	1
11	Wire Clamp	13629	11
12	Spring Hose Holder	24651	1

# NOTE: See page 70 for information on the control box



## Bale Deck

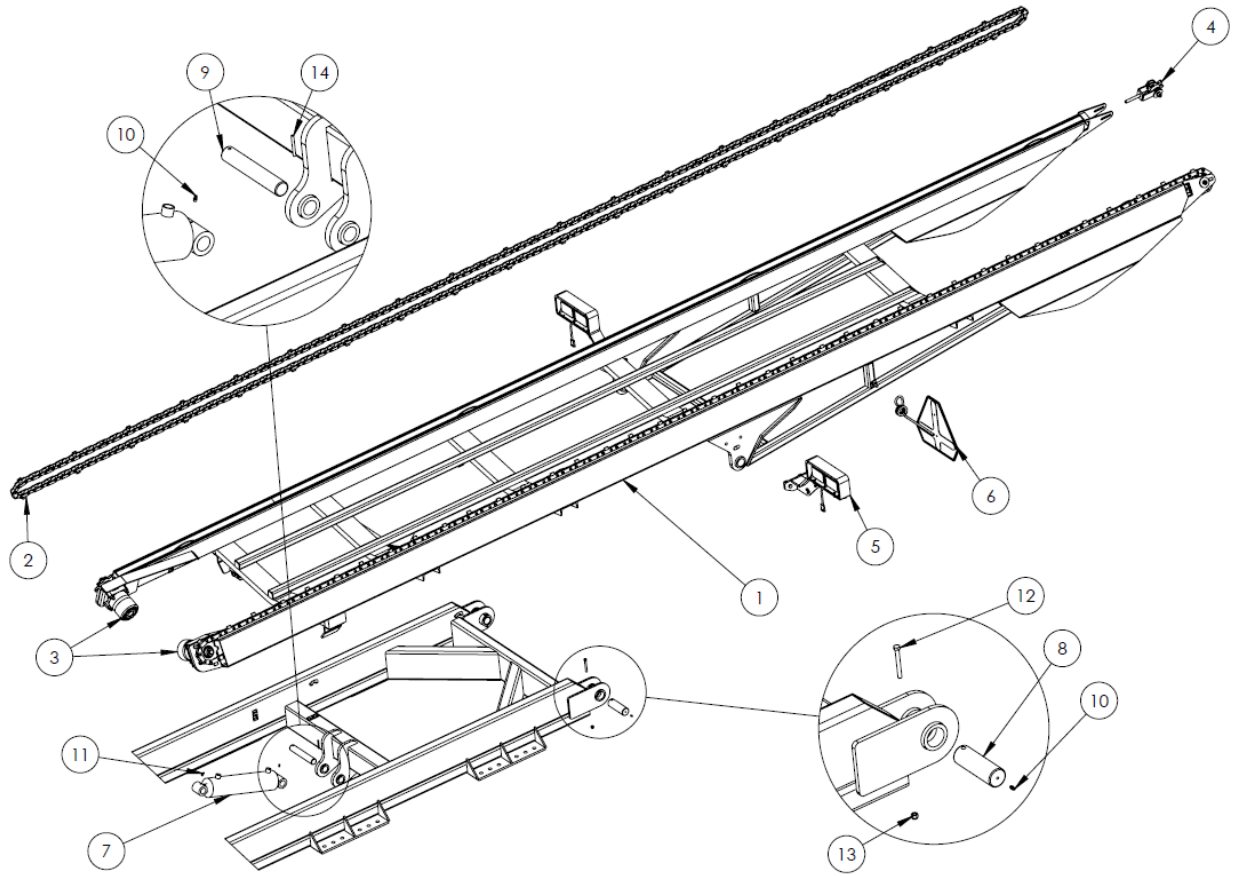

#	DESCRIPTION	PART #	QTY
1	Bale Deck	24727	1
2	2082 Chain with Tabs Connector Link	24748 23093	2
3	Chain Motor Assembly	See breakdown pg. 53	-
4	Idler Sprocket Assembly	See breakdown pg. 54	-
5	Light Assembly	See breakdown pg. 55	-
6	SMV Sign	See breakdown pg. 55	-
7	Hydraulic Cylinder, 4 x 14 x 2"	Comes with straight zerks	23094
8	Deck Pivot Pin	1-15/16 x 5-7/8"	23596
9	Cylinder Pin	1-1/2 x 8-7/8"	24132
10	Grease Zerk, 1/4"		16364
11	Grease Zerk, 1/4" x 45°		20888
12	Bolt, 3/8 x 3-1/4"		23325
13	Nut, 3/8" Nylon Lock		10806
14	Roll Pin, 1/4 x 2-1/4"		23544

### Chain Motor Assembly

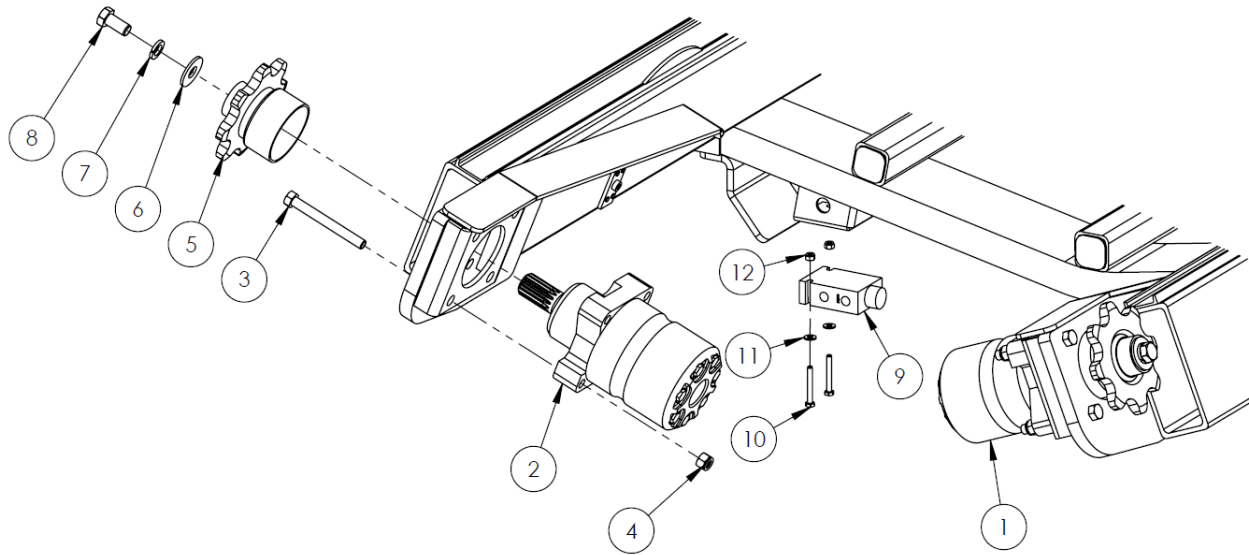

#	DESCRIPTION	PART #	QTY
1	Hydraulic Motor, Left Hand Seal Kit	28702	1
		25891	
2	Hydraulic Motor, Right Hand Seal Kit	28703	1
		25891	
3	Bolt, 1/2 x 4-1/2"	15574	8
4	Nut, 1/2" Nylon Lock	10241	8
5	Sprocket, 8 Tooth	23747	2
6	Washer, 5/8" Heavy Flat	21390	2
7	Washer, 5/8" Lock	10276	2
8	Bolt, 5/8 x 1-1/4" NF	13328	2
9	Flow Divider Valve	11742	1
10	Bolt, 1/4 x 2"	11663	2
11	Washer, 1/4" Flat	11666	2
12	Nut, 1/4" Nylon Lock	11664	2

### Idler Sprocket Assembly

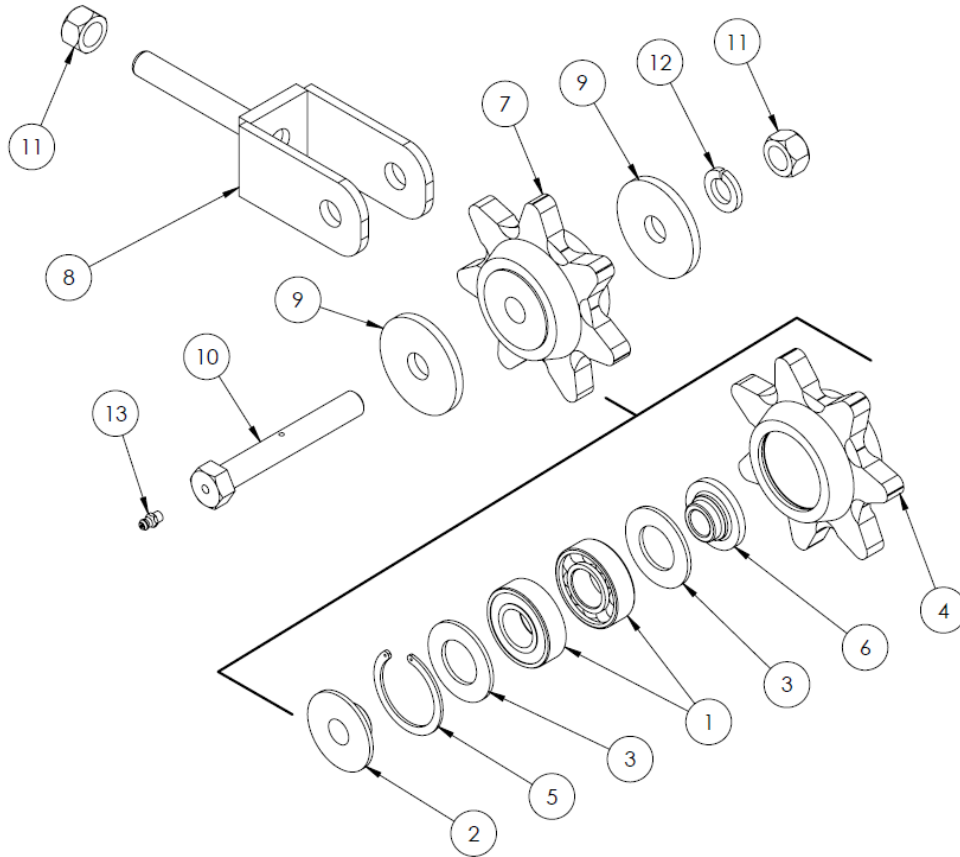

#	DESCRIPTION	PART #	QTY	
1	Idler Sprocket Bearing	23757	(2)	
2	Bushing, Snap Ring Side	27681	(1)	
3	Spacer	27680	(2)	
4	Idler Sprocket (Sprocket only)	27497	(1)	
5	Snap Ring	23755	(1)	
6	Bushing, Non-Snap Ring Side	27682	(1)	
7	Complete Idler Sprocket Assembly	Includes 1 - 6	27683	1
8	Chain Tensioner Bracket	31163	1	
9	Washer, 5/8" Heavy Flat	17972	2	
10	Grease-able 5/8" x 4-1/2" Bolt	23597	1	
11	Nut, 5/8"	10176	2	
12	Washer, 5/8" Lock	10276	1	
13	Grease Zerk	16364	1	

### Lights and SMV Sign

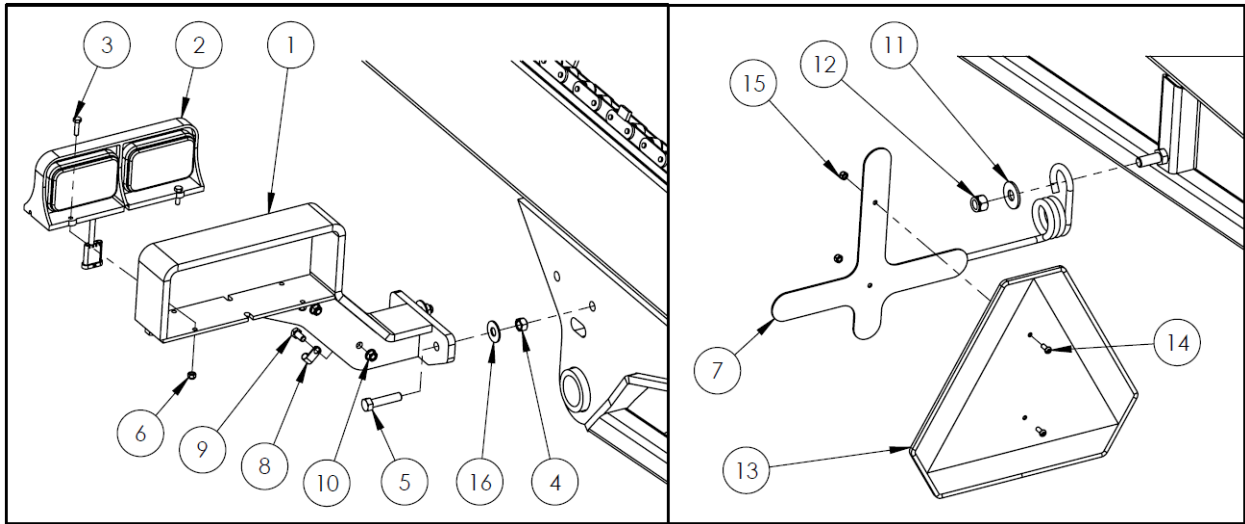

#	DESCRIPTION	PART #	QTY
1	Light Bracket	28689	2
2	Left Light (shown) Right Light	31087 31088	1 1
3	Bolt, 1/4 x 1"	11810	8
4	Nut, 1/2" Stover Lock	20154	4
5	Bolt, 1/2 x 2-1/4"	11820	4
6	Nut, 1/4" Nylon Lock	11664	8
7	SMV Sign Bracket	24656	1
8	Wire Clamp	13629	4
9	Bolt, 3/8 x 3/4"	11816	4
10	Nut, 3/8" Serrated Flange	10271	4
11	Bolt, 5/8" Heavy Flat	21390	1
12	Nut, 5/8" Nylon Lock	10364	1
13	SMV Sign	Comes as kit. Includes 14,15 22411	1
14	Bolt, 1/4 x 5/8" Screw Head	NSS	(2)
15	Nut, 1/4" Nylon Lock	NSS	(2)
16	Washer, 1/2" Flat	11668	2

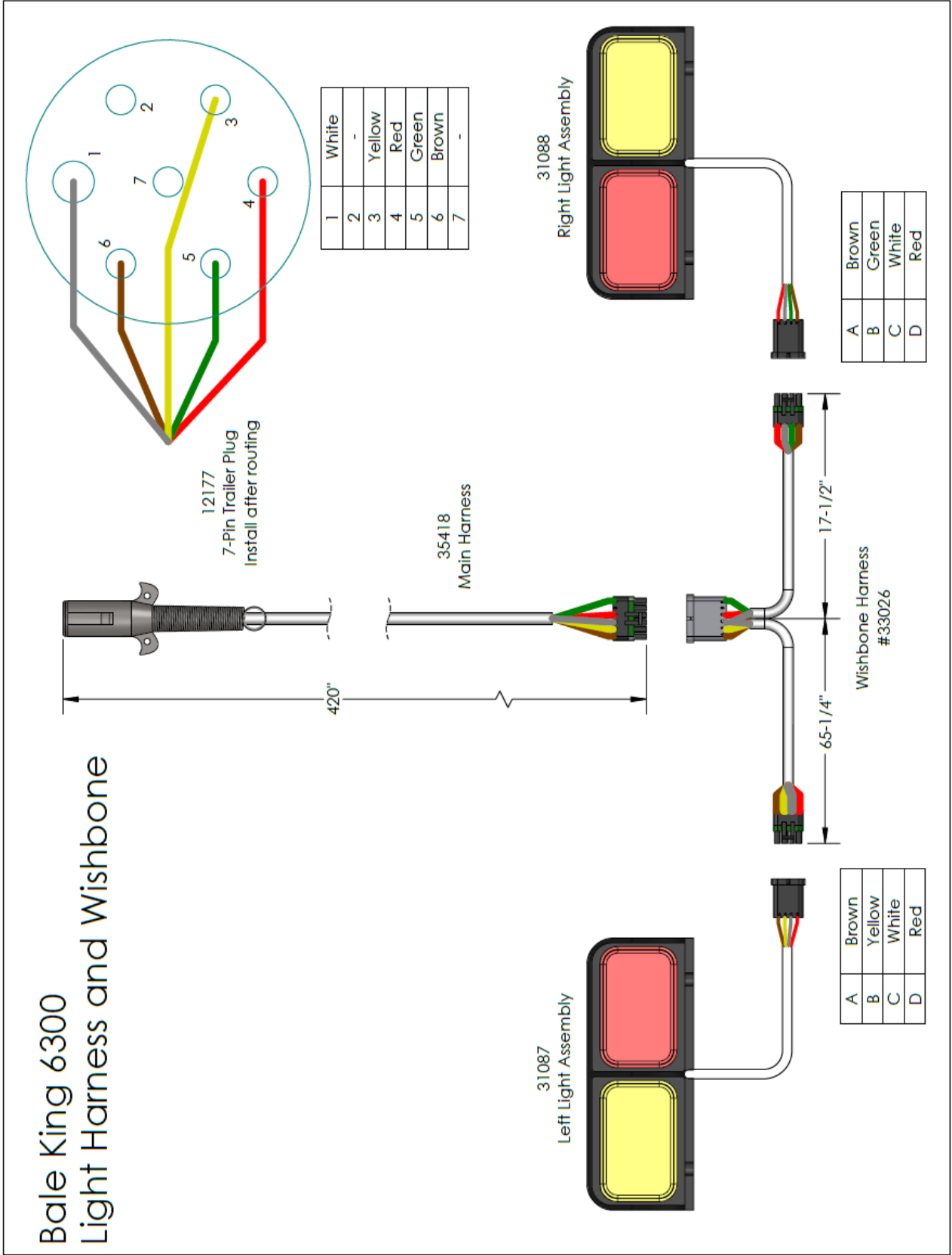

### Decals



1



2



3



4

5

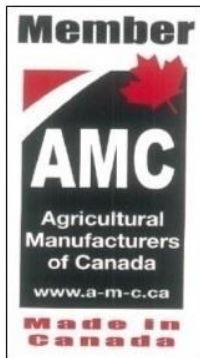

6



7



8

Re-Torque wheels after 1 hour use.  
see operators manual

11



9



10



12



13



14



**DECALS**

#	DESCRIPTION	PART #	QTY
<b>1</b>	“BALE KING” “6300”	32804 35075	2 2
<b>2</b>	“DANGER”, PTO	12219	2
<b>3</b>	“DANGER”, Discharge	12230	4
<b>4</b>	“DANGER”, Stand Clear of Lift	12229	2
<b>5</b>	AMC Member	12239	1
<b>6</b>	FEMA Member	25347	1
<b>7</b>	Wheel Torque Reminder	28385	4
<b>8</b>	Deflector Safety Lock	22292	1
<b>9</b>	Red Reflector	28383	3
<b>10</b>	Amber Reflector	28384	9
<b>11</b>	Hoop Adjustment	32782	1
<b>12</b>	Total Ration **TR Only**	24862	1
<b>13</b>	Speed Limit Decal	33159	1
<b>14</b>	Hyd. Decal	33143	1

## Total Ration Grain Tank Option

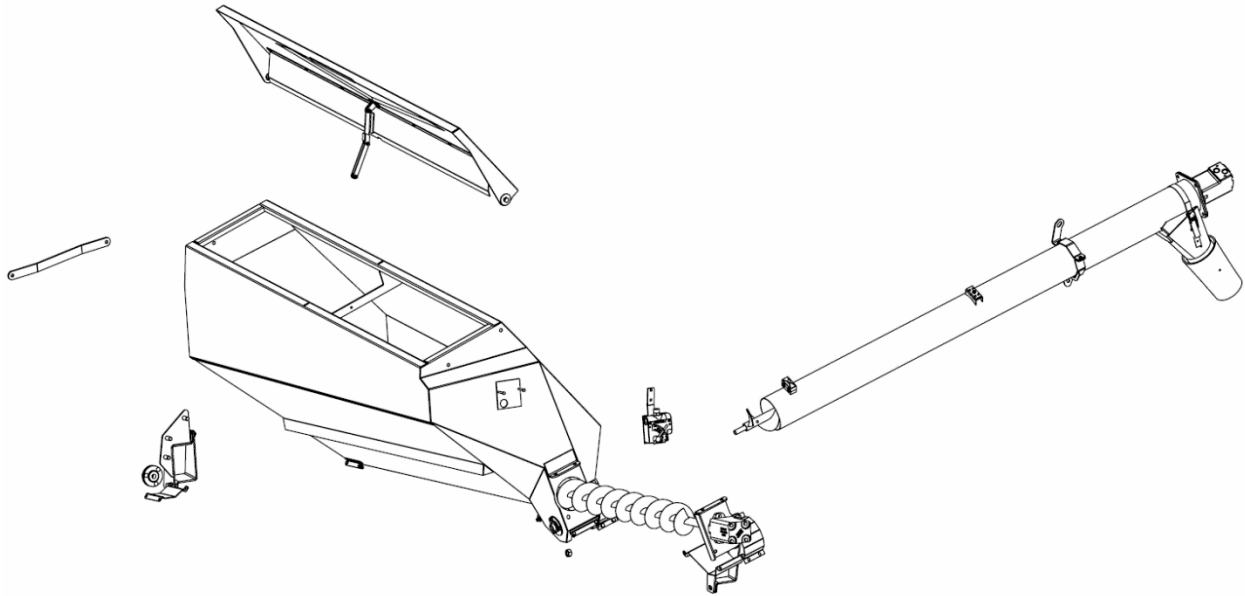

Item #	Description	
1	Tank Front	Page 60
2	Tank Rear	Page 62
3	Cross Auger	Page 64
4	Lid	Page 66

### Total Ration Tank Front

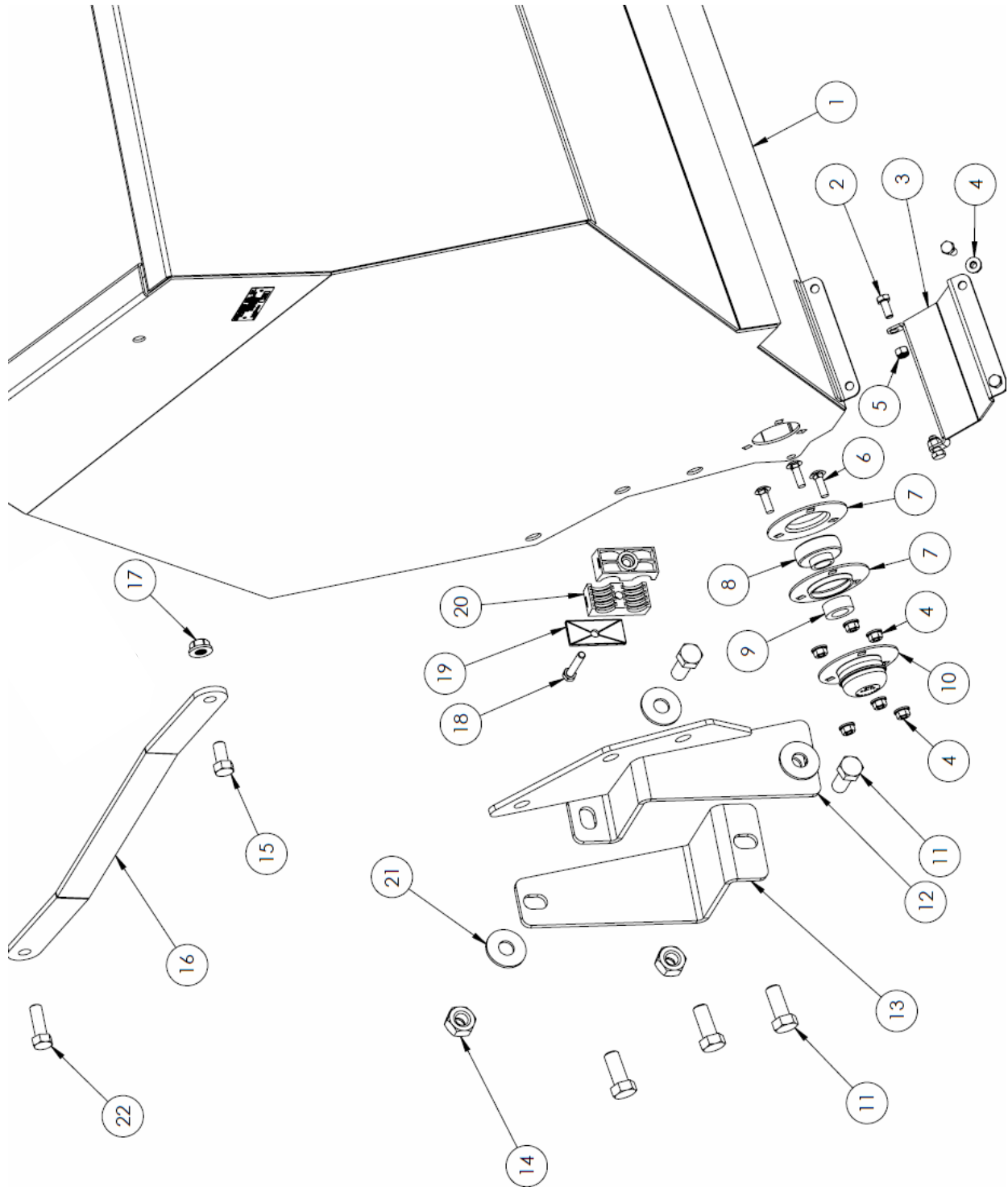

**Total Ration Tank Front**

#	DESCRIPTION	PART #	QTY
1	Total Ration Grain Tank	30199	1
2	Bolt, 5/16" x 3/4"	20903	4
3	Tank Cleanout Cover	30237	1
4	Nut, 5/16" Serrated Flange	11814	8
5	Nut, 5/16" Nylock	11815	2
6	Bolt, 5/16" x 1" Carriage	17884	3
7	Bearing, 3-Bolt Pressed Flange Housing	10368	2
8	Bearing, 3/4" Includes #9	10366	1
9	Bearing Lock Collar	10367	1
10	Bearing Cover	25117	1
11	Bolt, 5/8" x 1-1/2"	10173	5
12	6300 Front Mount Bracket	30252	1
13	6300 Front Mount Strap	30250	1
14	Nut, 5/8" Stover Lock	20150	2
15	Bolt, 1/2" x 1"	10824	2
16	Grain Tank Top Strap	30402	2
17	Nut, 1/2" Serrated Flange	10273	2
18	Bolt, 5/16" x 1.75"	21726	1
19	Hydraulic Hose Clamp Cap, Large	21715	1
20	Hydraulic Hose Clamp, 1/2"	21561	2
21	Washer, 5/8" Flat	13975	4
22	Bolt, 1/2" x 1-1/2"	10174	2

### Total Ration Tank Rear

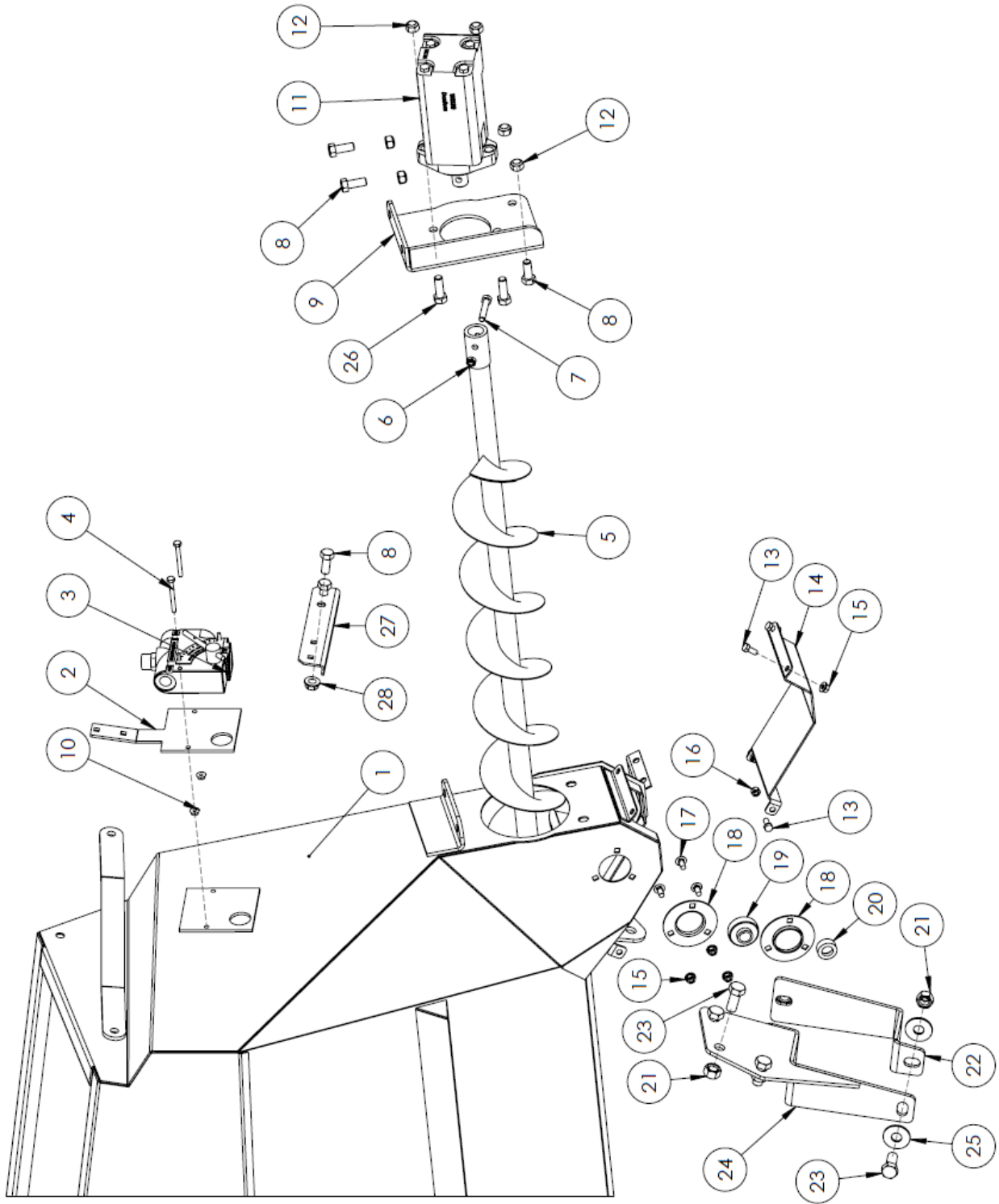

**Total Ration Tank Rear**

#	DESCRIPTION	PART #	QTY	
1	Total Ration Grain Tank	30199	1	
2	5300 SMV Sign Mount	5300TR Only	30389	-
3	Flow Control Valve	10455	1	
4	Bolt, 1/4 x 2-1/2"	20954	2	
5	Tank Auger	30175	1	
6	Nut, 3/8" Stover Lock	17586	1	
7	Bolt, 3/8" x 2"	10279	1	
8	Bolt, 1/2 x 1-1/4"	10240	4	
9	Tank Motor Mount	30233	1	
10	Nut, 1/4" Serrated Flange	11812	2	
11	Tank Motor, WS230	31172	1	
12	Nut, 1/2" Stover Lock	14393	6	
13	Bolt, 5/16 x 3/4"	20903	4	
14	Cross Auger Cleanout Cover	30235	1	
15	Nut, 5/16" Serrated Flange	11814	5	
16	Nut, 5/16" Nylon Lock	11815	2	
17	Bolt, 5/16 x 3/4" Carriage	11662	3	
18	Bearing, 3-Bolt Pressed Flange Housing	10368	2	
19	Bearing, 3/4"	Includes #20	10366	1
20	Bearing Lock Collar	10367	1	
21	Nut, 5/8" Stover Lock	20150	5	
22	6300 Rear Mount Strap	30255	1	
23	Bolt, 5/8" x 1-1/2"	10173	5	
24	6300 Rear Mount Bracket	30257	1	
25	Washer, 5/8" Flat	13975	4	
26	Bolt, 1/2 x 1-1/2"	10174	2	
27	SMV Sign Bracket	5300TR Only	33799	-
28	Nut, 1/2" Serrated Flange	10273	-	



### Total Ration Cross Auger

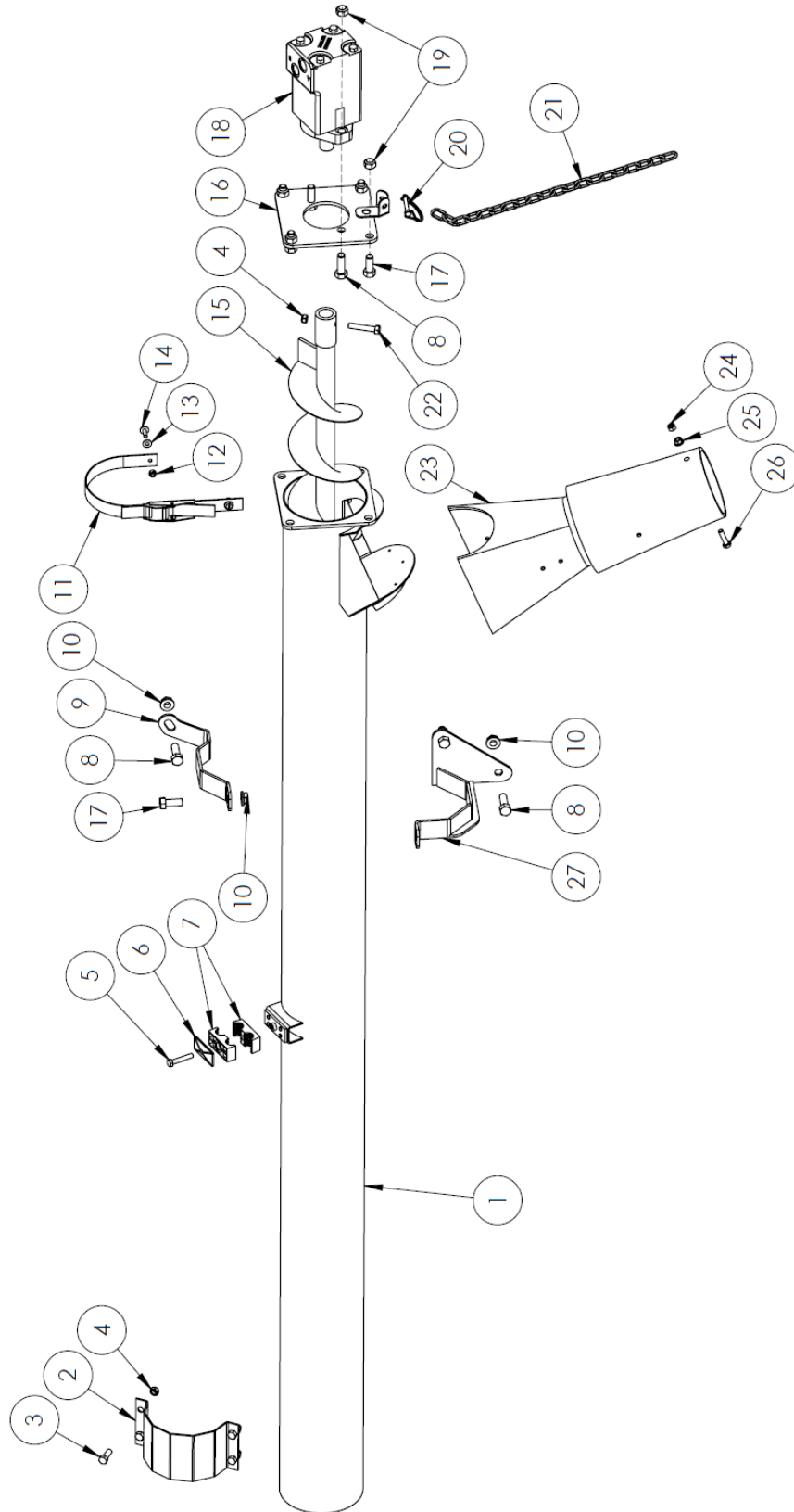

**Total Ration Cross Auger**

#	DESCRIPTION	PART #	QTY	
1	Cross Auger Pipe	30179	1	
2	Cross Auger Half Clamp	30401	1	
3	Bolt, 3/8" x 1"	13806	4	
4	Nut, 3/8" Stover Lock	17586	5	
5	Bolt, 5/16" x 1.75"	21726	1	
6	Hydraulic Hose Clamp Cap, Large	21715	1	
7	Hydraulic Hose Clamp, 1/2"	21561	2	
8	Bolt, 1/2" x 1-1/2"	10174	5	
9	Cross Auger Top Clamp	30187	1	
10	Nut, 1/2" Serrated Flange	10278	8	
11	Spout Strap	Includes both parts	25122	1
12	Nut, 1/4" Nylon Lock	11664	2	
13	Washer, 1/4" Flat	14448	2	
14	Bolt, 1/4" x 3/4" Truss Head	17638	2	
15	Cross Auger	30169	1	
16	Cross Auger Motor Mount	30194	1	
17	Bolt, 1/2" x 1-1/4"	10240	4	
18	Cross Auger Motor, WS080	30132	1	
19	Nut, 1/2" Stover Lock	14393	6	
20	Lock Pin, 1/4" x 1.25"	13951	1	
21	Chain, 3/16" x 20 links	25121	1	
22	Bolt, 3/8" x 2"	10279	1	
23	Auger Spout	10543	1	
24	Nut, 5/16" Nylon lock	11815	1	
25	Nut, 5/16" Serrated Flange	11814	1	
26	Bolt, 5/16" x 1-1/4"	24418	1	
27	Cross Auger Bottom Clamp	30189	1	

### Total Ration Tank Lid

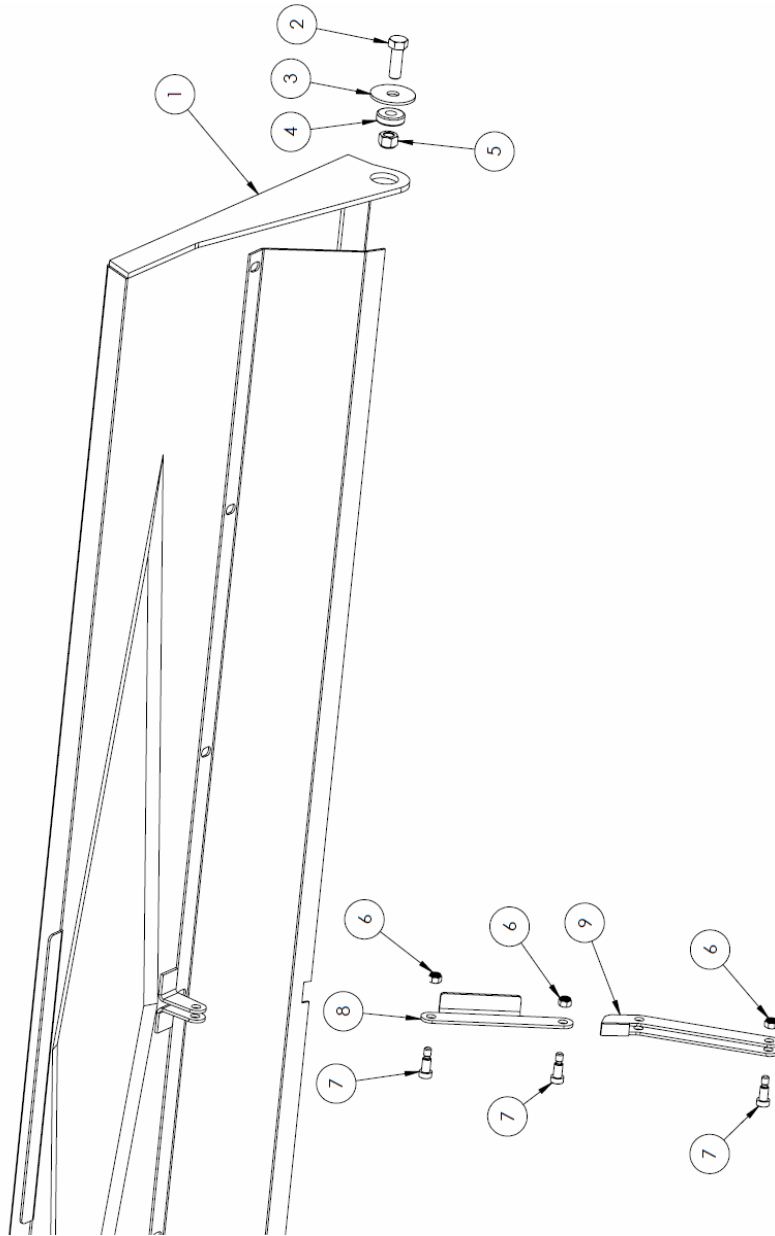

#	DESCRIPTION	PART #	QTY
1	Grain Tank Lid	30165	1
2	Bolt, 1/2" x 1-1/4"	10240	2
3	Washer, 1/2" Fender	10238	2
4	Bushing, 1/2" ID x 1.250" OD	10239	2
5	Nut, 1/2" Stover Lock	14393	2
6	Nut, 5/16" Nylon Lock	11815	3
7	Bolt, 3/8" x 5/8" Shoulder	30466	3
8	Lid Upper Support	30163	1
9	Lid Lower Support	30166	1

### Fine Chop Option

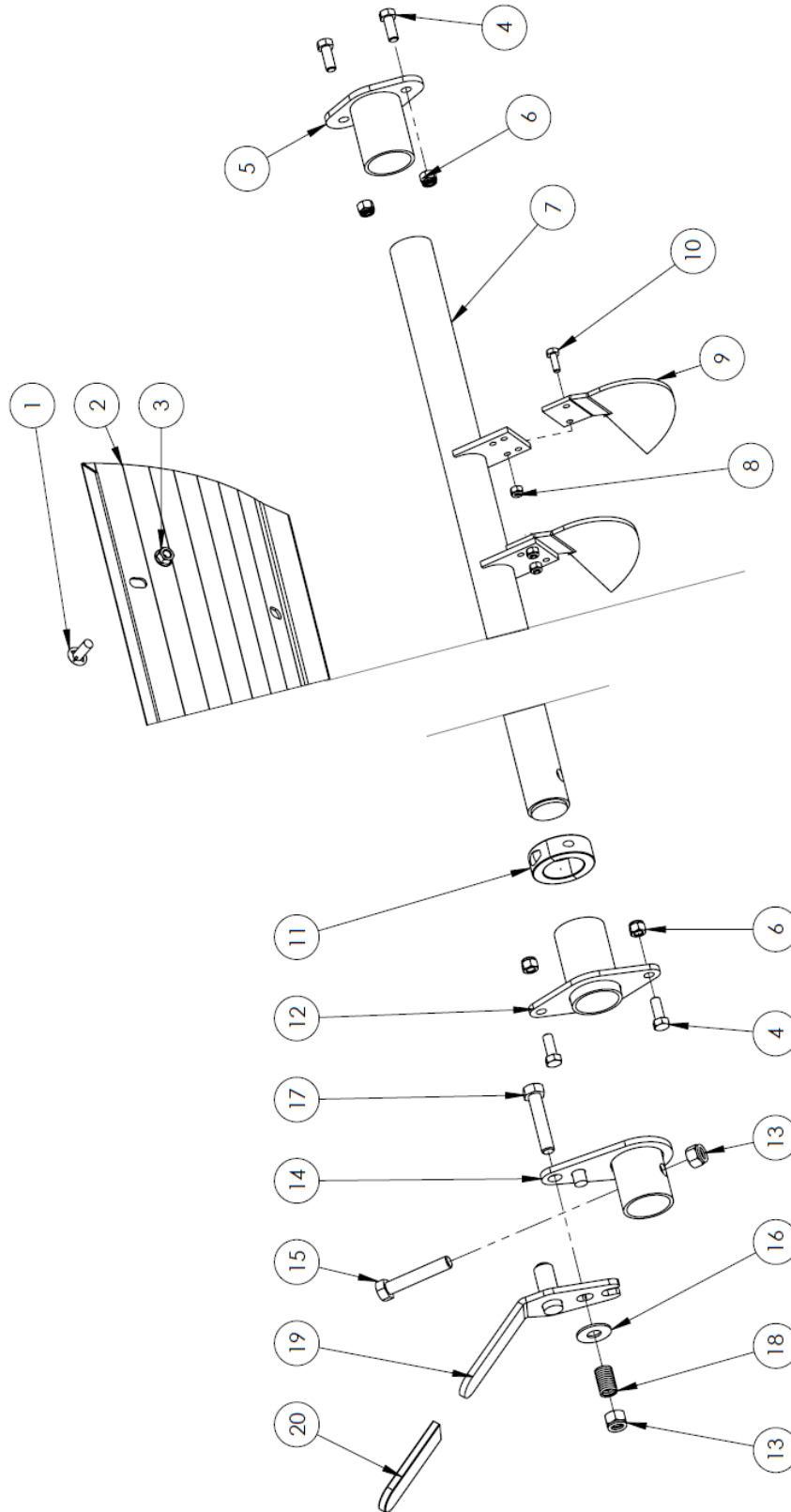

**Fine Chop Option**

#	DESCRIPTION	PART #	QTY
	<b>Fine Chop Cover</b> * IF NO FINE CHOP INSTALLED *		
<b>1</b>	Fin Bolt, 3/8" x 3/4"	10807	8
<b>2</b>	Fine Chop Cover Plate	22438	1
<b>3</b>	Nut, 3/8" Serrated Flange	10271	8
	<b>Fine Chop Kit</b> * Optional *	32117	1
<b>4</b>	Bolt, 3/8" x 1"	13806	4
<b>5</b>	Fine Chop Mount	22444	1
<b>6</b>	Nut, 3/8" Nylon Lock	10806	4
<b>7</b>	Fine Chop Bar	32118	1
<b>8</b>	Nut, 1/4" Nylon Lock	11664	26
<b>9</b>	Fine Chop Blade	10404	13
<b>10</b>	Bolt, 1/4" x 3/4"	11809	26
<b>11</b>	Split Collar	12792	1
<b>12</b>	Fine Chop Front Mount	32122	1
<b>13</b>	Nut, 1/2" Nylon Lock	10241	2
<b>14</b>	Fine Chop Pivot	32127	1
<b>15</b>	Bolt, 1/2" x 2-3/4"	12378	1
<b>16</b>	Flat Washer, 1/2"	11668	1
<b>17</b>	Bolt, 1/2" x 2-1/2"	10804	1
<b>18</b>	Compression Spring	21713	1
<b>19</b>	Fine Chop Handle	32132	1
<b>20</b>	Rubber Cover	10297	1

### Twine Cutter Option

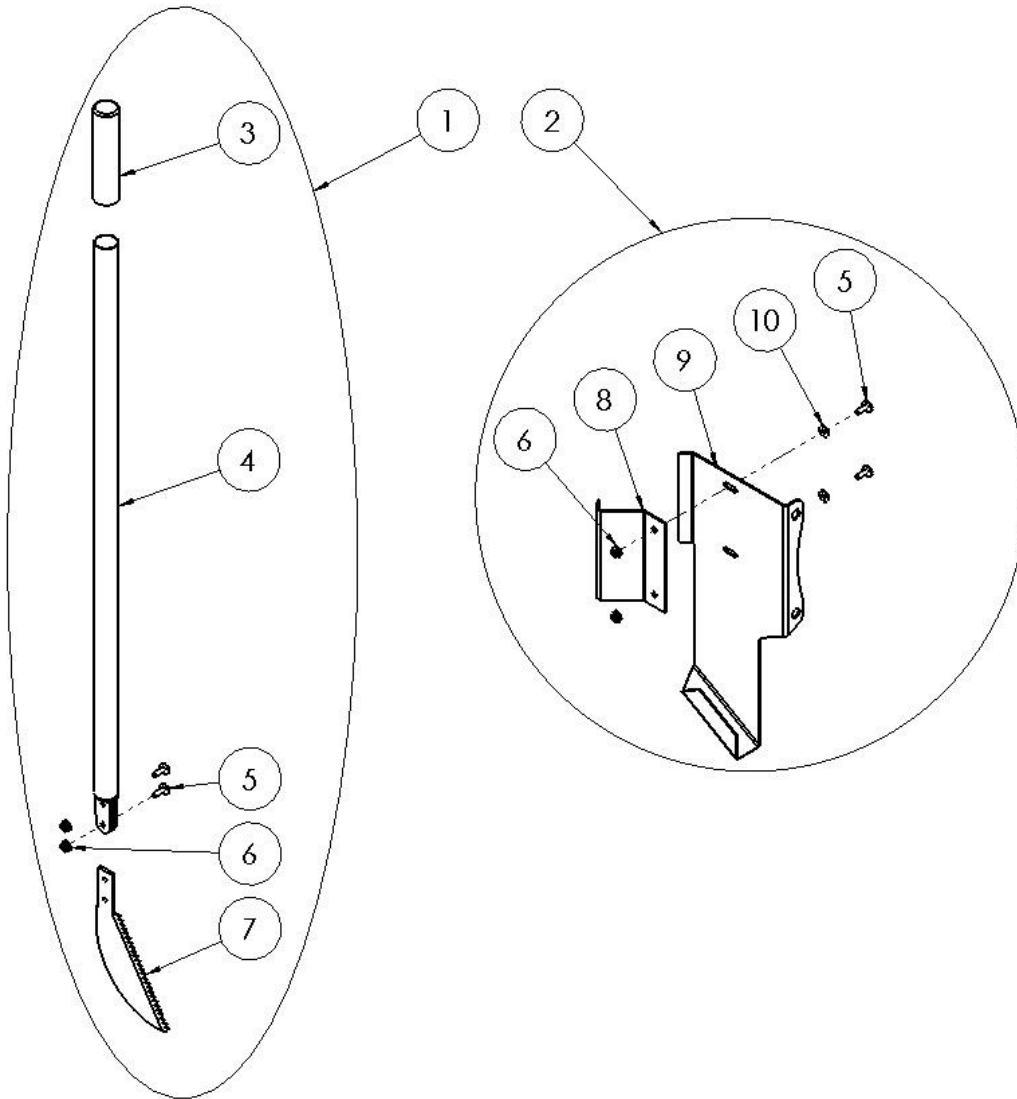

#	DESCRIPTION	PART #	QTY
	<b>Twine Cutter Kit</b>	<b>17686</b>	<b>1</b>
<b>1</b>	Twine Cutter Handle Kit	-	1
<b>2</b>	Twine Cutter Holder Kit	21549	1
<b>3</b>	Rubber Handle Cap	17587	1
<b>4</b>	Twine Cutter Handle	20862	1
<b>5</b>	Bolt, 1/4" x 3/4" Truss Head	17638	4
<b>6</b>	Nut, 1/4" Serrated Flange	11812	4
<b>7</b>	Twine Cutter Blade	17438	1
<b>8</b>	Twine Cutter Holder Inside Bracket	17690	1
<b>9</b>	Twine Cutter Holder Outside Bracket	17691	1
<b>10</b>	Flat Washer, 1/4"	11666	2



### Diverter Control Box

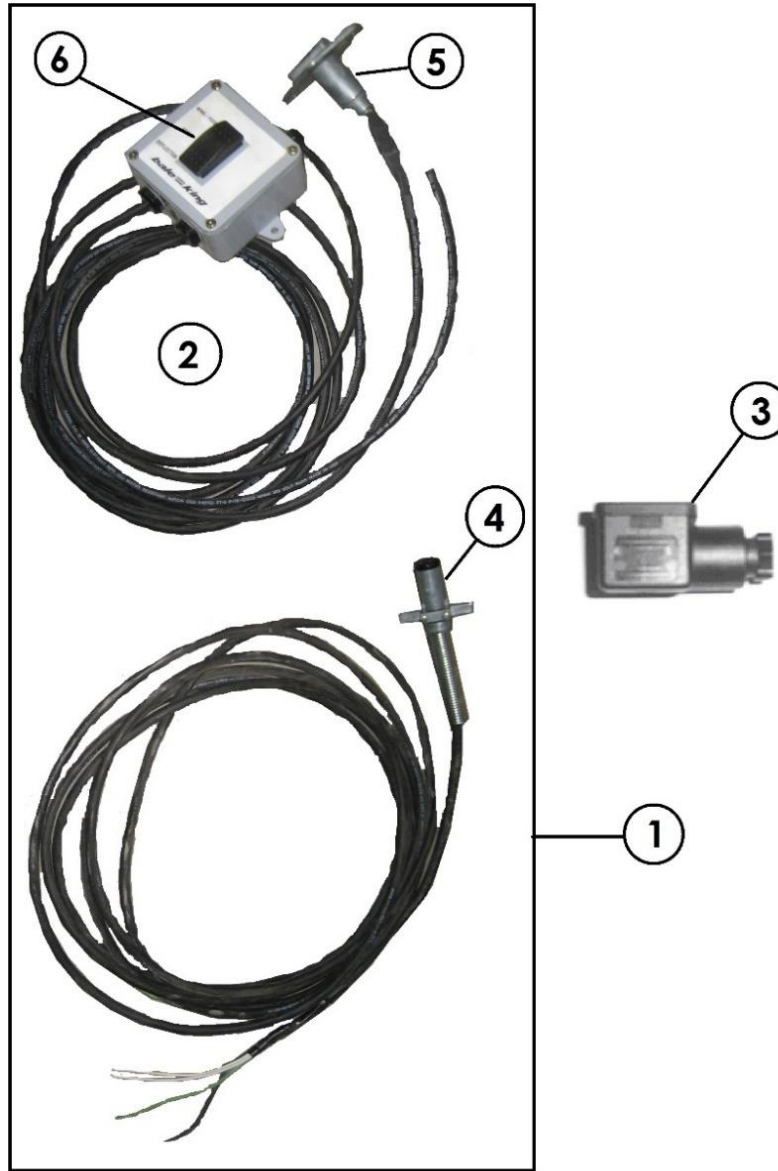

#	DESCRIPTION	PART #	QTY
1	Complete Control Box with Harness (Standard) Complete Control Box with Harness (4 Function) #	24466 33134	1
2	Complete Control Box with Cab to Hitch Harness (6300 Series)	-	1
3	Square Plug for Diverter Valve	13657	*
4	4-pin Trailer Plug	24691	1
5	4-pin Tractor Plug	24690	1
6	3-way Switch	13561	1

\* NOTE: 1 plug is needed for each diverter valve.  
# NOTE: Only used on 6300TR with 3 diverter valves

### Diverter Machine Side Harness

#### FRONT DIVERTER TO REAR DIVERTER HARNESS

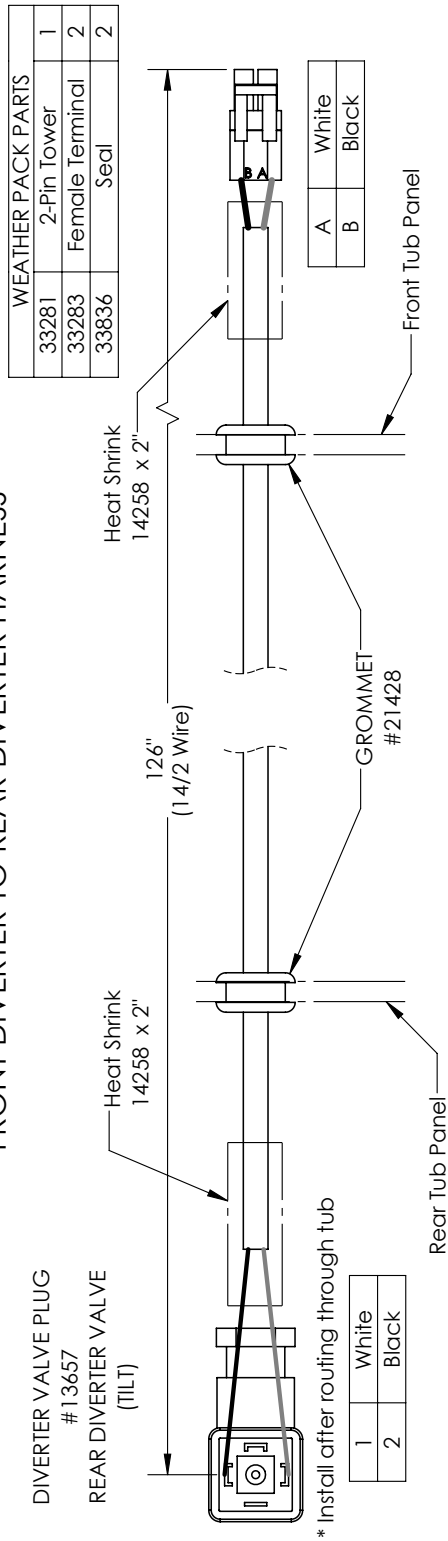

#### FRONT DIVERTER TO TRACTOR HARNESS

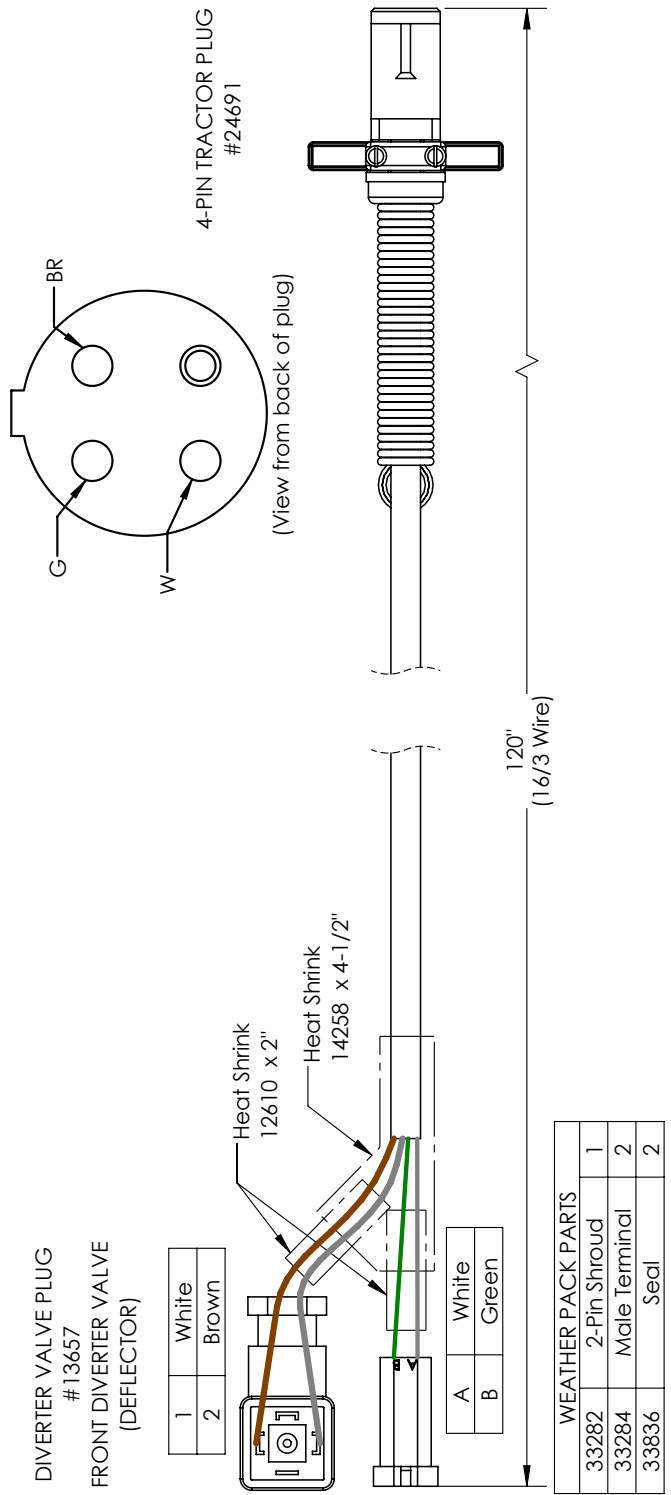

### Diverter Control Box #24466

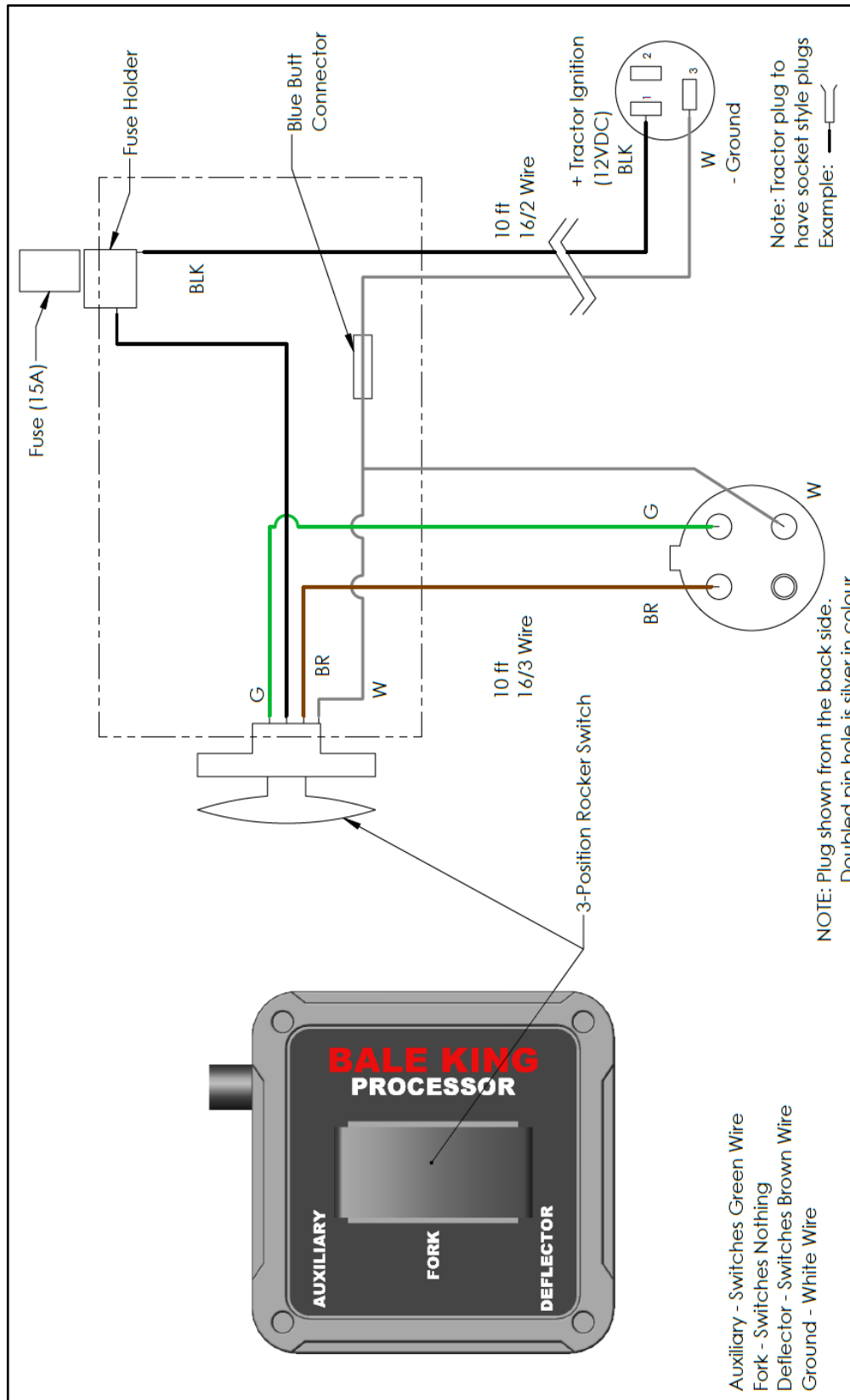

### Diverter Machine Side Harness (TR Option)

#### FRONT DIVERTER TO REAR DIVERTER HARNESS

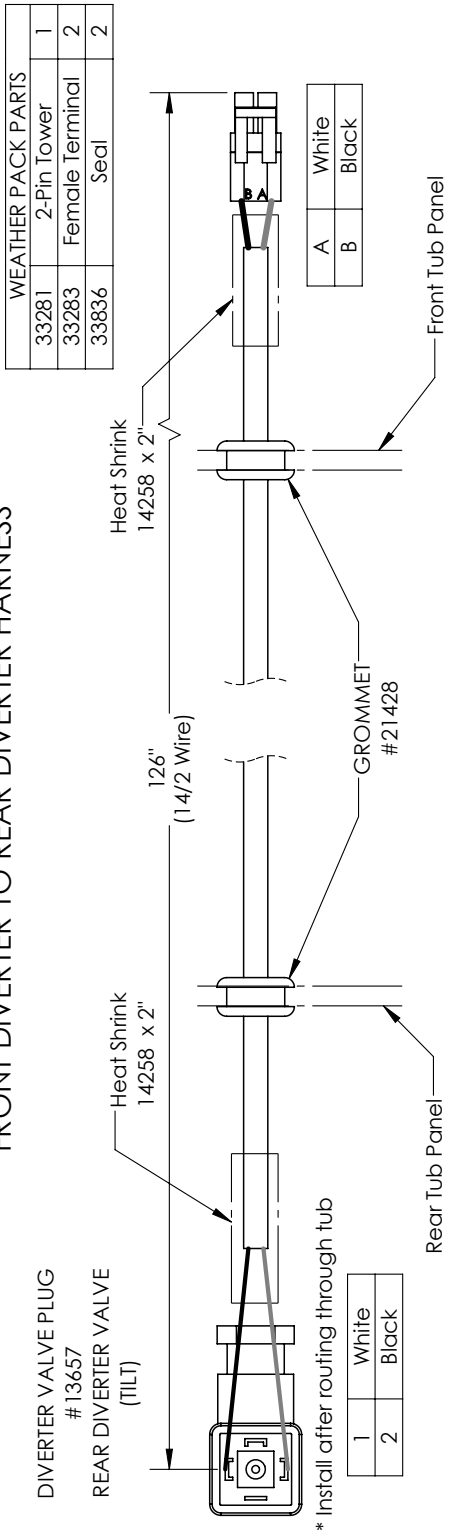

#### FRONT DIVERTER TO TRACTOR HARNESS

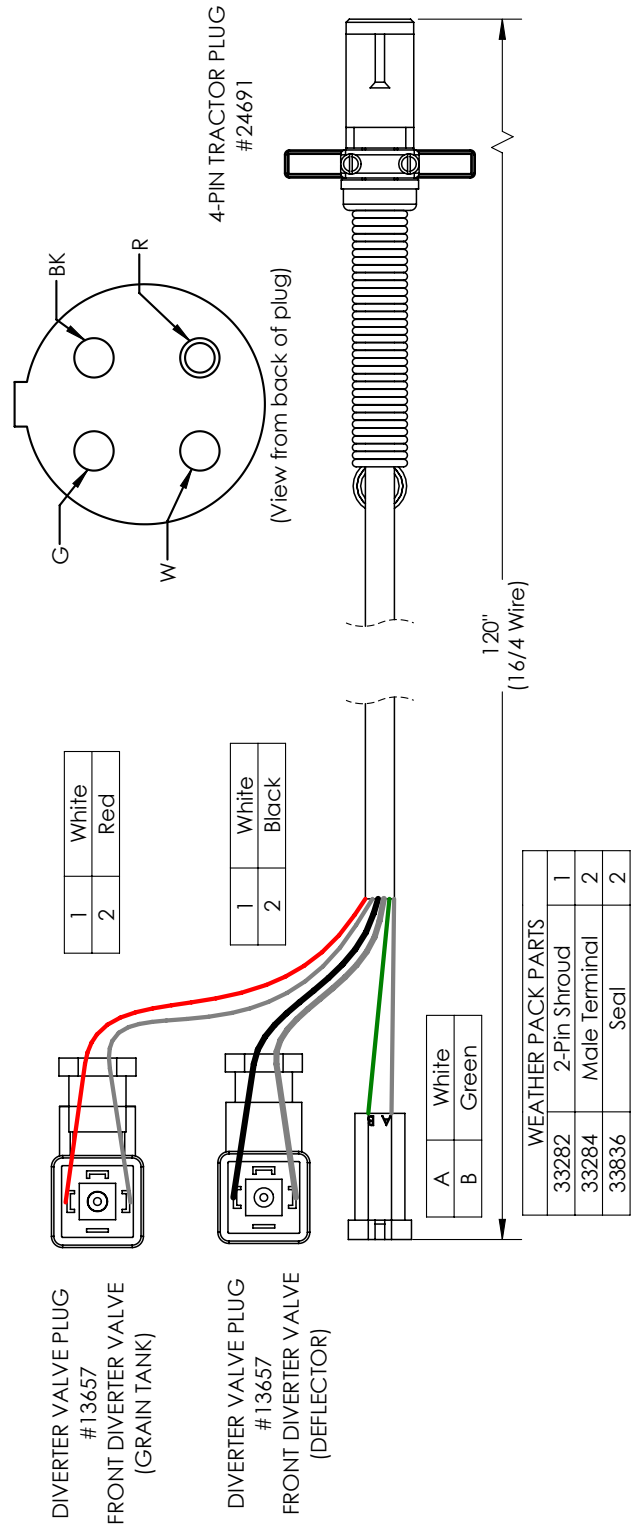



### Diverter Control Box #33134 (4 Function with Additional Push Button Switch)

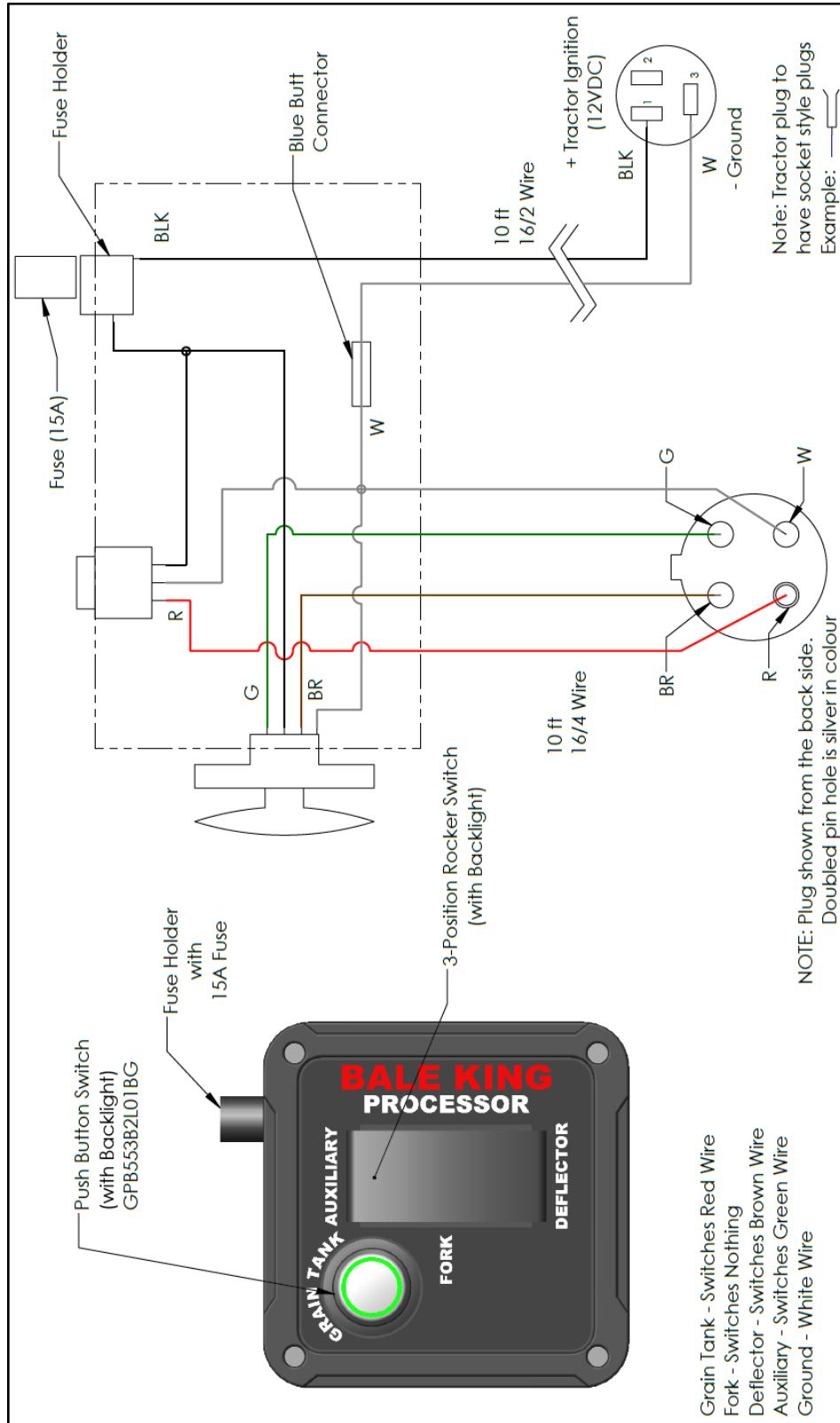

## Hydraulic Schematics

### HYDRAULIC COMPONENTS

#	DESCRIPTION	PART #
<b>AA</b>	Hydraulic Motor * Seal Kit	Agitators
		25872 25891
<b>BB</b>	Hydraulic Motor * Seal Kit	Left Chain
		28702 25891
<b>CC</b>	Hydraulic Motor * Seal Kit	Right Chain
		28703 25891
<b>DD</b>	Hydraulic Motor – WS230	TR Tank Auger
<b>EE</b>	Hydraulic Motor – WS080	TR Cross Auger
<b>FF</b>	Hydraulic Cylinder - 3 x 18 x 1.5” * Seal Kit * Stopper Kit	Rear Forks
		21717 20807 21860
<b>GG</b>	Hydraulic Cylinder – 4 x 14 x 2” *Seal Kit	Bed Tilt
<b>HH</b>	Hydraulic Cylinder - 1.5 x 6 x 1” * Seal Kit	Deflector
<b>II</b>	Flow Divider Valve	Agitator Motors
<b>JJ</b>	Flow Divider Valve	Chain Motors
<b>KK</b>	Pilot-operated Check Valve	Deflector
<b>LL</b>	Diverter Valve * Nut & O-Ring * Magnet * Stack Kit	Fork, Tilt, Deflector
		11743 17977 11789
<b>MM</b>	Flow Control Valve	TR Only
<b>NN</b>	Check Valve, 8MJ-8FB	TR Only
<b>OO</b>	Pioneer Tip, 8FB	
<b>PP</b>	Hose Marker, Long Red	Agitators
<b>QQ</b>	Hose Marker, Short Red	
<b>RR</b>	Hose Marker, Long Blue	Fork, Tilt, Deflector
<b>SS</b>	Hose Marker, Short Blue	
<b>TT</b>	Hose Marker, Long Yellow	Chain
<b>UU</b>	Hose Marker, Short Yellow	

**NOTE:** Quantities vary depending on machine set-up. Order as required.

**HYDRAULIC FITTINGS**

<b>#</b>	<b>DESCRIPTION</b>	<b>PART #</b>
<b>A</b>	Adaptor, 12MB-8MJ90	22174
<b>B</b>	Adaptor, 10MB-8MJ90	12169
<b>C</b>	Adaptor, 10MB-8MJ45	23844
<b>D</b>	Adaptor, 10MB-8MJ	10161
<b>E</b>	Adaptor, 10MB-6MJ45	22722
<b>F</b>	Adaptor, 10MB-6MJ	11739
<b>G</b>	Adaptor, 8MB-8MJ	10561
<b>H</b>	Adaptor, 8MB-8MJ90	12169
<b>J</b>	Adaptor, 8MB-6MJ	11740
<b>K</b>	Adaptor, 8MB-6MJ90	10200
<b>L</b>	Adaptor, 8MJBH	28774
<b>M</b>	Adaptor, 8MJBH90	10531
<b>N</b>	Adaptor, 8MJBHL-8MJT	21581
<b>P</b>	Adaptor, 8MBR-8MJT	22159
<b>Q</b>	Adaptor, 8FJXR-8MJT	11768
<b>R</b>	Adaptor, 6MB-6MJ	10162
<b>S</b>	Adaptor, 6MB-6MJ90	10201
<b>T</b>	Adaptor, 6MJ-6FJX90	12162
<b>U</b>	Adaptor, 6MJBH90	10187
<b>V</b>	Adaptor, 6MBR-6MJT	23726
<b>W</b>	Adaptor, 6MB-6MJ Orifice (1/32")	17436

**NOTE:** Quantities vary depending on machine set-up. Order as required.



**HYDRAULIC HOSES**

#	DIA.	LENGTH	ENDS
1	1/2"	260" OAL	8FJX - 8FJX
2	1/2"	132" OAL	8FJX - 8MB
3	1/2"	122" OAL	8FJX - 8MB
4	1/2"	122" OAL	8FJX - 8FJX90
5	1/2"	102" OAL	8FJX90 - 8FJX
6	1/2"	98" OAL	8MB - 8FJX
7	1/2"	81" OAL	8FJX - 8FJX
8	1/2"	70" OAL	8FJX - 8FJX
9	1/2"	48" OAL	8FJX - 8FJX
10	1/2"	44.5" OAL	8FJX - 8FXJ90
11	1/2"	42" OAL	8FJX - 8FJX45
12	1/2"	40" OAL	8FJX - 8FJX45
13	1/2"	33" OAL	8FJX - 8FJX45
14	1/2"	33" OAL	8FJX - 8MB
15	1/2"	24" OAL	8FJX - 8FJX90
16	3/8"	179" OAL	6FJX - 6FJX
17	3/8"	173" OAL	6FJX - 6FJX90
18	3/8"	122" OAL	6FJX - 8MB
19	3/8"	79.5" OAL	6FJX - 6FJX
20	3/8"	78" OAL	6FJX - 8FJX90
21	3/8"	53" OAL	6FJX - 8FJX
22	3/8"	35" OAL	6FJX - 8FJX
23	3/8"	33.5" OAL	6FJX - 8FJX
24	3/8"	17.25" OAL	6FJX - 6FJX90
25	3/8"	16.25" OAL	6FJX - 6FJX
26	3/8"	13.5" OAL	6FJX - 6FJX
27	3/8"	11.25" OAL	6FJX - 6FJX90
28	3/8"	8.75" OAL	6FJX - 6FJX
29	3/8"	8.5" OAL	6FJX - 6FJX
30	1/4"	20.25" OAL	6FJX90 - 6FJX
31	1/4"	16.25" OAL	6FJX - 6FJX90L
32	1/4"	13.5" OAL	6FJX - 6FJX
33	1/4"	12.25" OAL	6FJX - 6FJX90L

**NOTE:** Hoses are not available for sale. Use the information above to have replacement hoses made up locally.  
All hoses should be double braid, with crimps rated for at least 3500 psi.

**FRONT PANEL – AGITATORS**

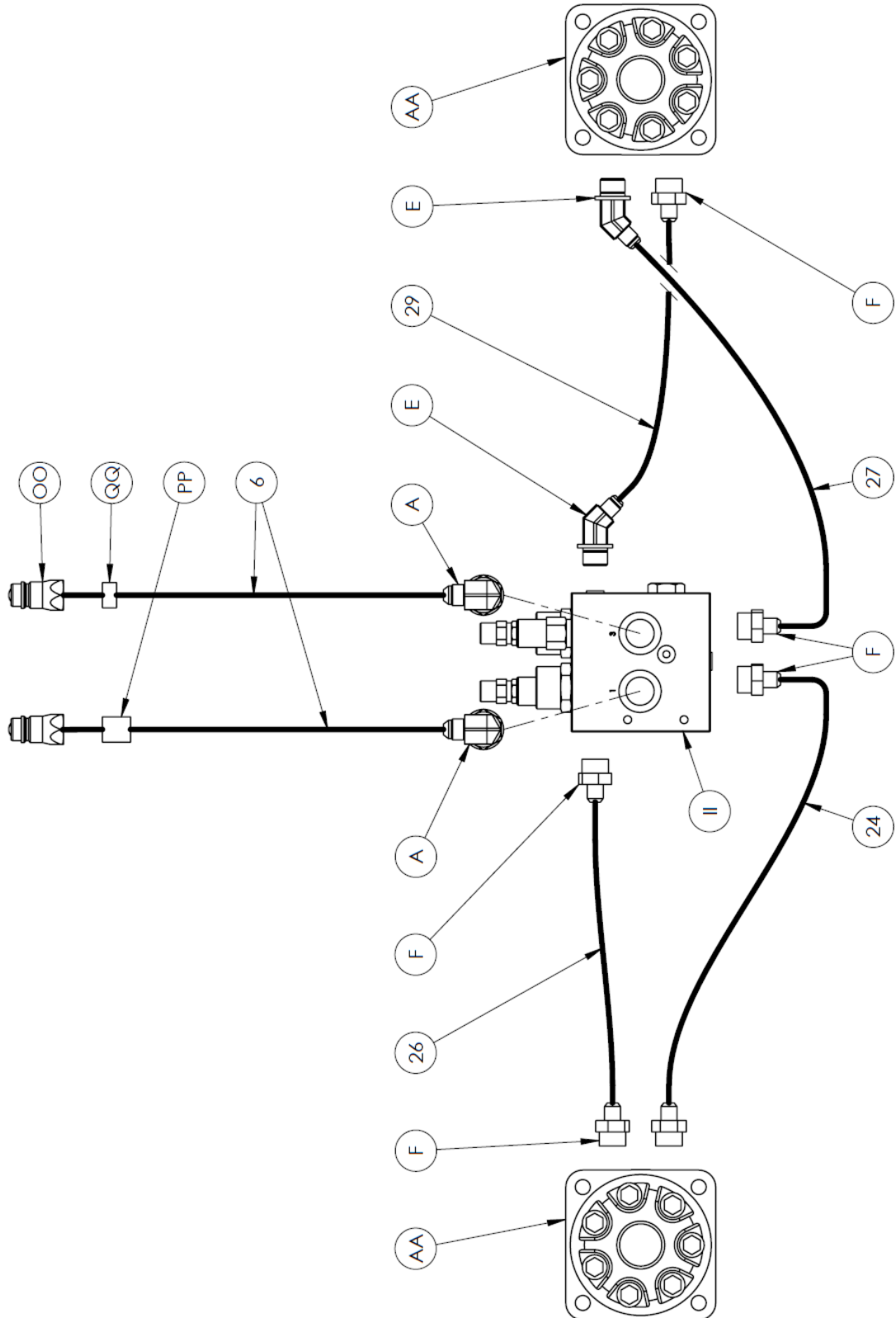

### FRONT PANEL - DEFLECTOR

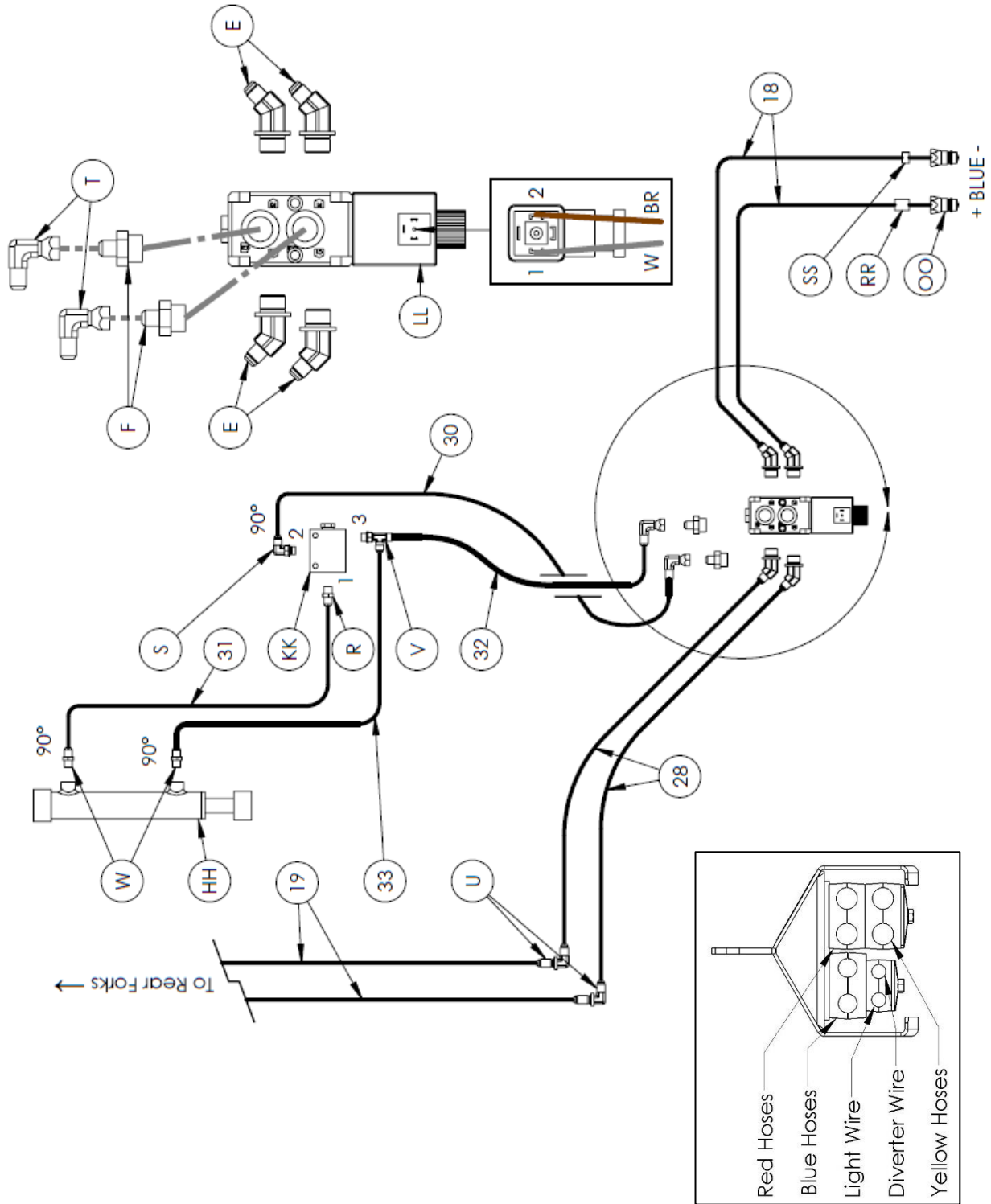

**FRONT PANEL – 6300TR**

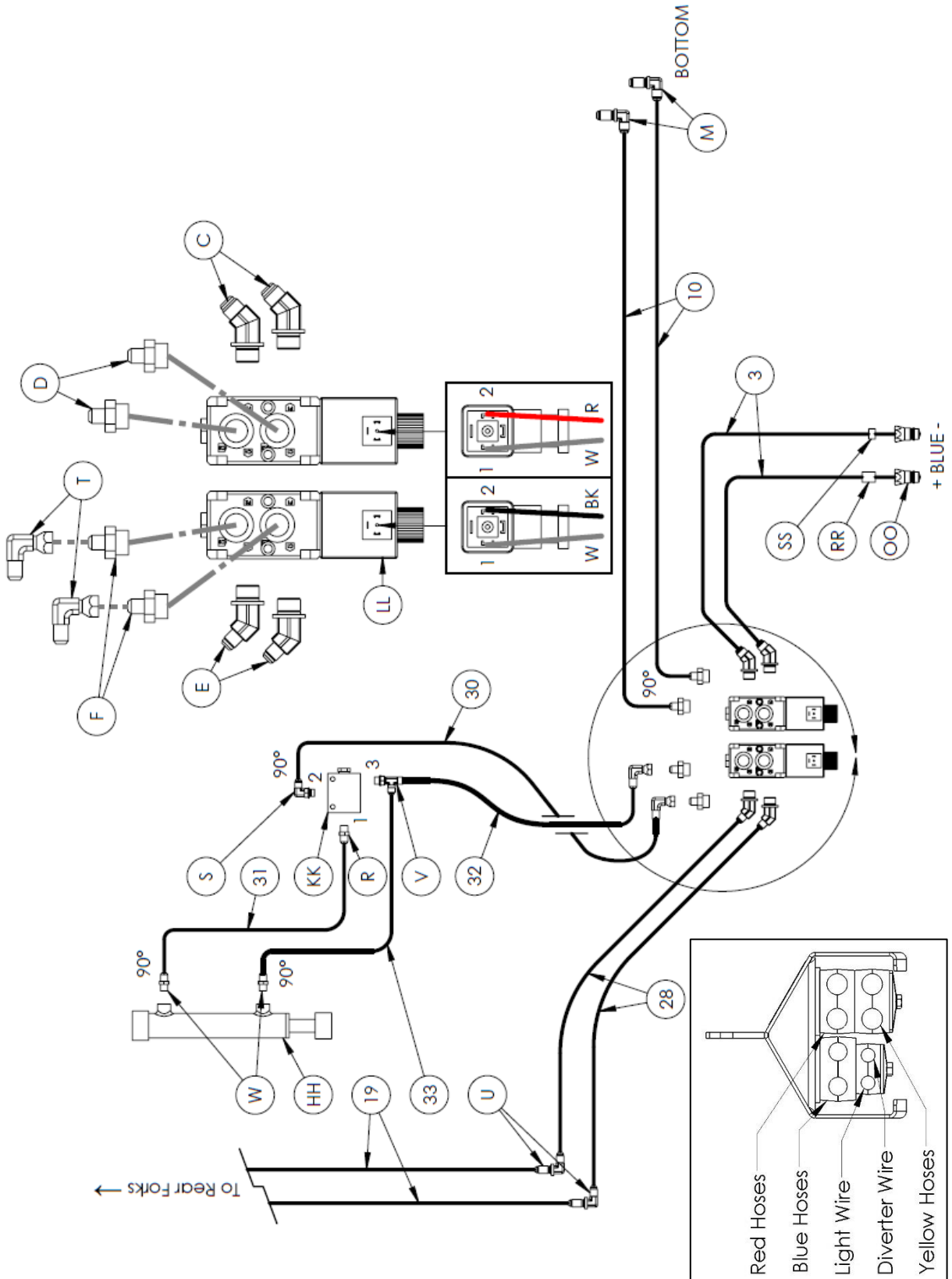

### REAR FORK & TILT

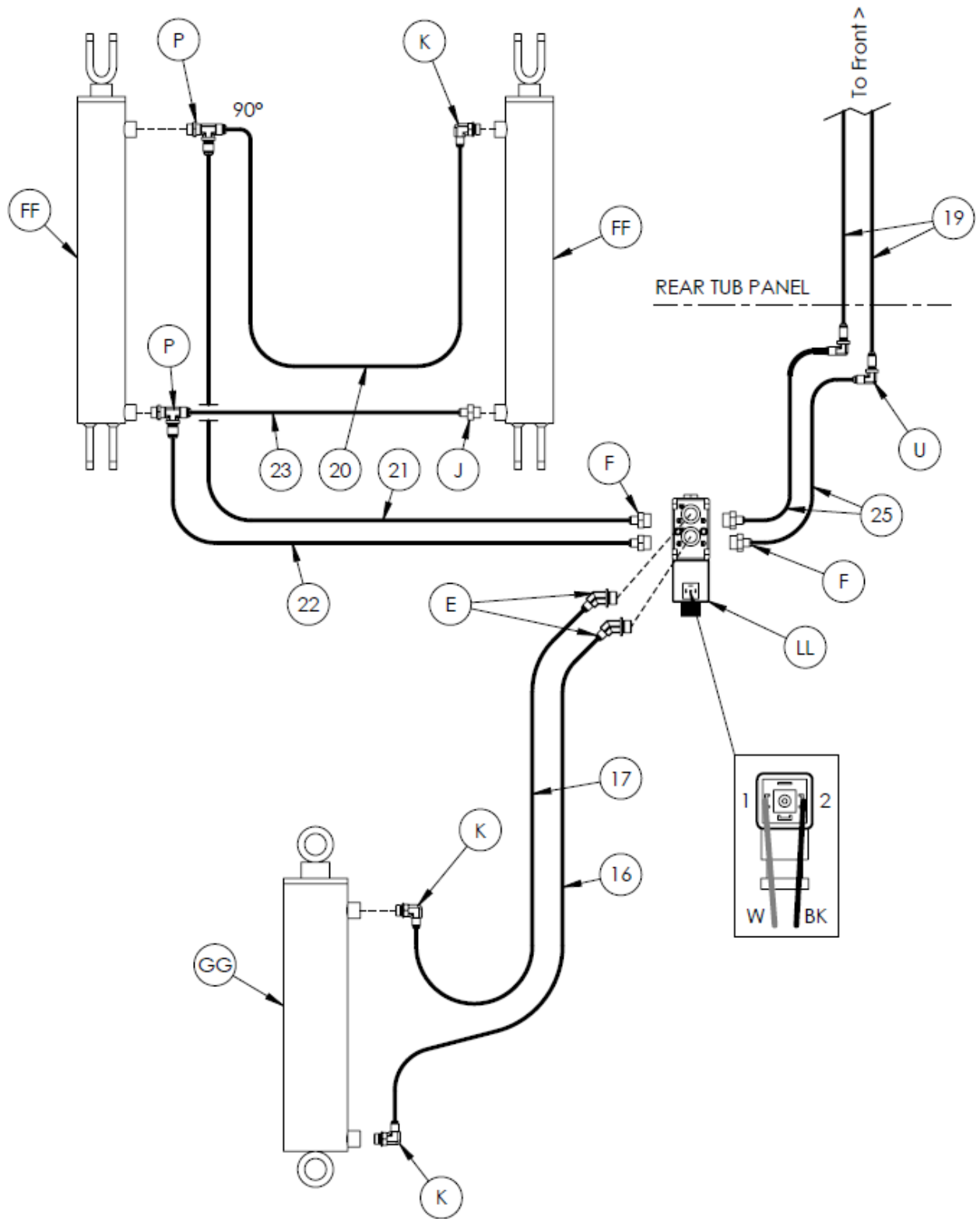

### BALE DECK CHAIN

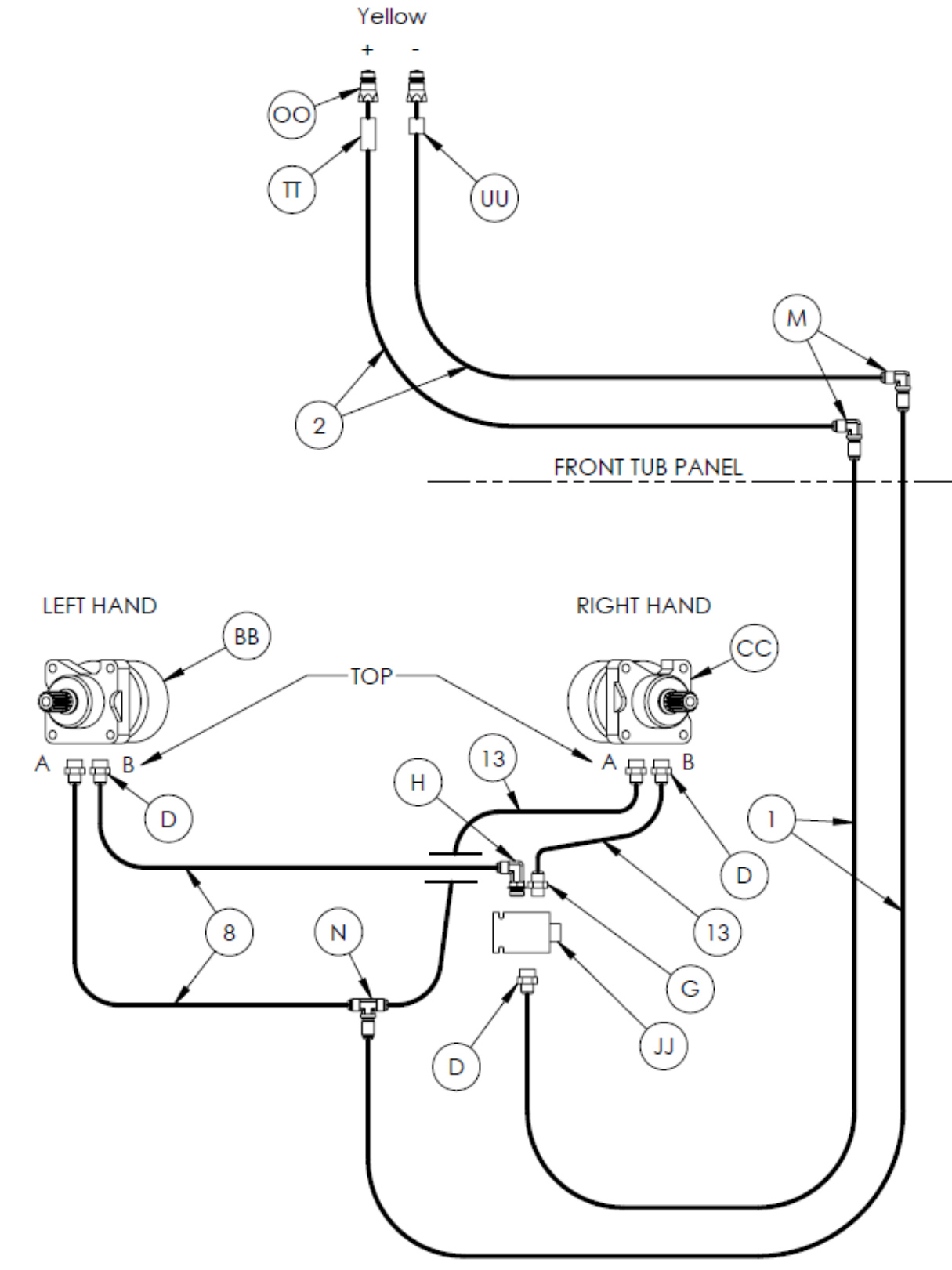

**TR GRAIN TANK KIT**

