



BRIDGEVIEW MFG. INC.



BALE KING 7400
Bale Processor

Operator and Parts Manual

Last Updated: December 2023

Bridgeview Manufacturing Inc.

P.O. Box 4

Gerald, Saskatchewan, Canada

S0A 1B0

Phone: 1-306-745-2711

Fax: 1-306-745-3364

Email: bmi@sasktel.net

www.bridgeviewmanufacturing.com



The Serial Number is located the front tub panel, next to the operator manual box.

Your Authorized Dealer

Your Serial Number

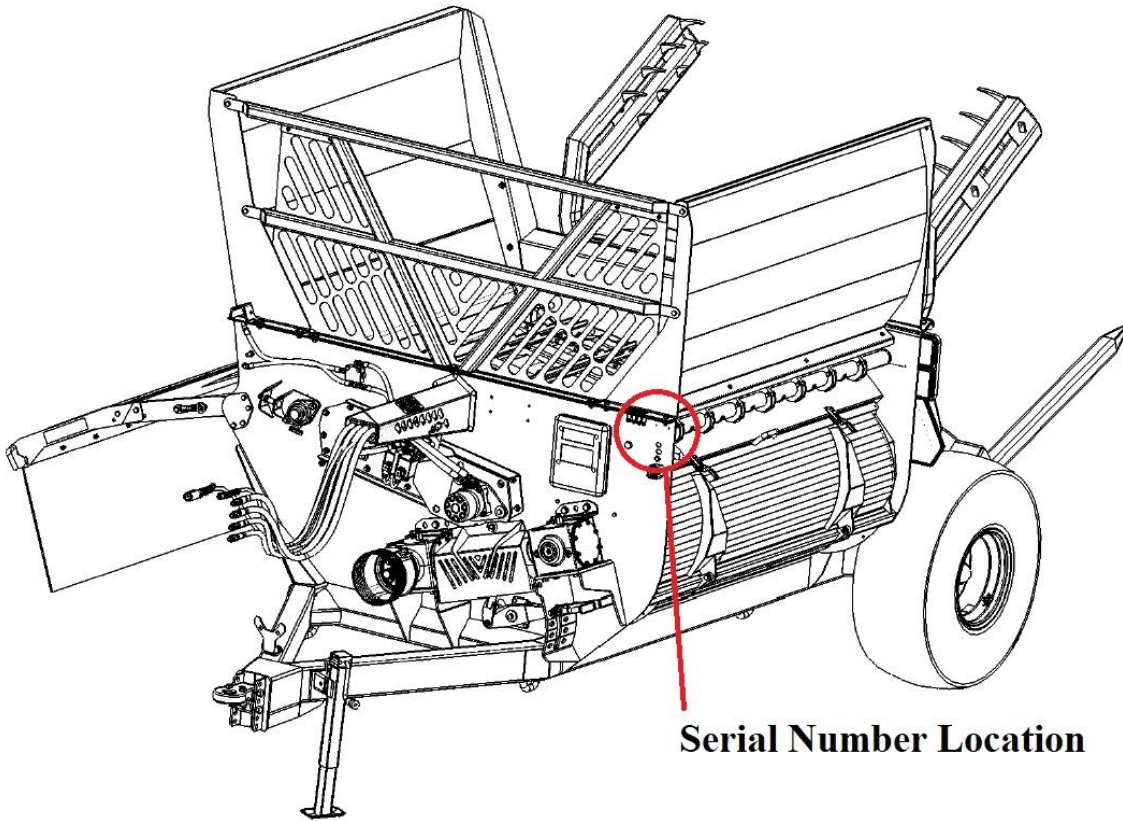

Serial Number Location

	<p>⚠ WARNING</p> <p>Failure to read and understand operator's manual & all safety signs could result in serious injury. Manual must remain with machine.</p>
--	---



TABLE OF CONTENTS

INTRODUCTION	1
Safety Precautions.....	1
Safety Decals	2
Transportation.....	5
FEATURES & OPERATION.....	7
Power Take-off	7
Hydraulics	11
Hose Holder	12
Implement Tongue	13
Rear Fork	13
Loading Bales	14
Deflector	15
Setting the Processor.....	18
Chain and Slats	19
Hoop Grate Adjustment	21
Optional Diverter Kit	24
Optional Fine Chop Kit.....	25
Optional 3 Bale Kit (7400X).....	26
Optional Flow Control Valve.....	30
Optional Back-up Camera.....	31
SERVICE AND MAINTENANCE.....	32
Greasing and Lubrication.....	32
Tires	36
Twine Removal.....	37
Gearbox and Flail Replacement Procedure.....	39
Trouble-shooting Guide	41
FEATURES AND SPECIFICATIONS	42
PARTS MANUAL.....	44





INTRODUCTION

Thank you for purchasing a **Bale King** bale processor. With the proper operation and service as outlined in this manual, the Bale King will provide you with years of trouble-free operation.

This is a complete safety, operation and service manual for the Bale King 7400. The manual covers in detail how to safely and effectively use your new processor. The procedures outlined in this manual should be followed to ensure safe operation and longevity of your machine. The service manual covers all parts you may need to order in case of accident, breakdown, or normal wear. Please read completely through this manual before beginning operation of your new machine.

Safety Precautions

The following safety precautions MUST be followed to ensure safe operation of the Bale King bale processor.

- **ALWAYS** turn **OFF** the tractor when leaving the operating platform.
- **DO NOT** stand in front of the discharge chute while the machine is running.
- **DO NOT** walk or move under the bale forks when they are in the upward position, either loaded with a bale, or connected to a running tractor.
- **DO NOT** enter the machine while in operation, or while connected to a running tractor.
- **DO NOT** open the rotor access panel while the machine is connected to a running tractor.
- **DO NOT** clean machine while in operation.
- **DO NOT** stick any device into the machine to clear debris while the machine is in operation.
- **ALWAYS** turn off the tractor when cleaning the processor, removing twine, or hooking up / unhooking the machine
- **ALWAYS** use safety chain when towing the machine on a highway.
- **DO NOT** operate if any part of the **PTO safety shielding** is missing or is not secured.



Safety Decals

Power Take-off

The operator must obey all safety labels and must maintain the proper shielding. A high percentage of drive-line injuries occur when safety shielding is missing or not functioning properly.

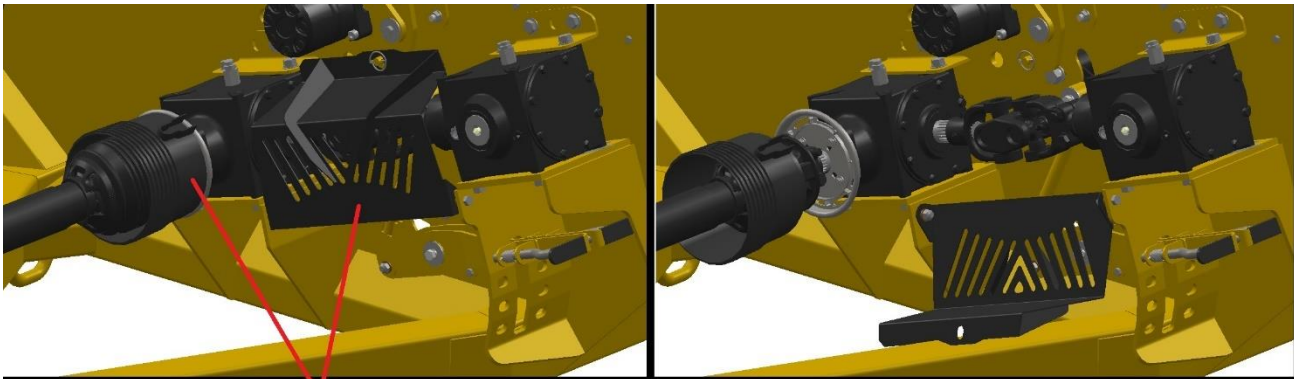
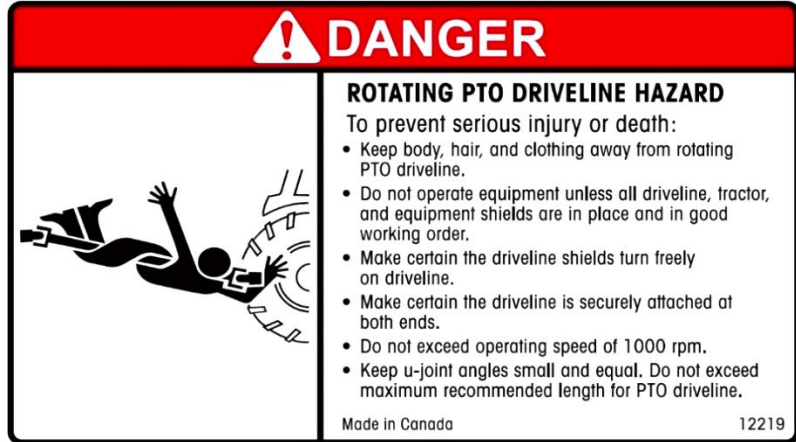

GUARDS MUST REMAIN IN PLACE DURING OPERATION

DANGER: *Contact with a rotating drive-line can cause serious injury or death.*



Discharge



DANGER: *Do not stand on the discharge side of the machine while it is in operation.*

Rear Fork Lift Area



DANGER: *Stand clear of lift area. Do not stand under the forks if tractor is running or if bale is resting on forks. Automatic hydraulic safety locks are installed.*



Deflector Safety Lock

Unlock for operation, lock for transport and storage.

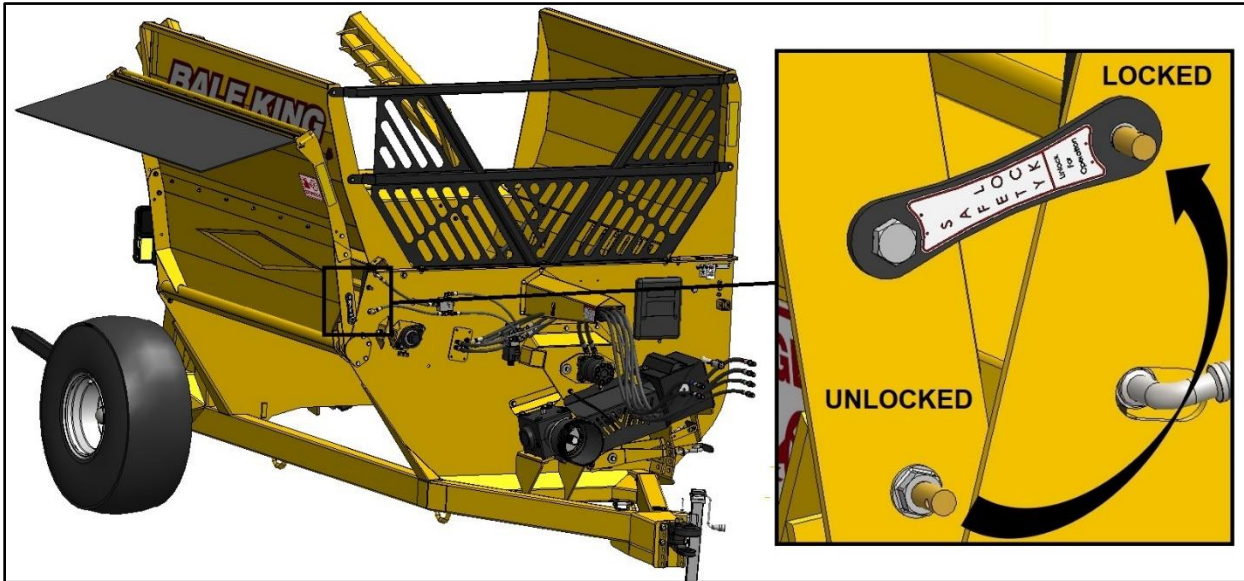

Rotor Access Panel



DANGER: *Never open the rotor access panel when the tractor is running.*



Transportation

The Bale King 7400 can be safely towed on public roads, provided the following precautions are met:

Weights and Dimensions

- The towing vehicle must be suitable for the weight being towed.
- Check with local authorities regarding transport on public roads. Follow all applicable laws and regulations.
- Be aware of your size and weight. Adjust your driving accordingly

	Empty		Loaded	
	7400	7400X¹	7400	7400X¹
Total Weight	5700 lb	6100 lb	9300 lb	11 500 lb
Hitch Weight	1800 lb	1800 lb	2000 lb	1700 lb
Length	17'-2"	17'-2"	21'-4"	21'-4"
Width ²	9'-4"	9'-4"	9'-4"	9'-4"
Height	8'-6"	8'-6"	10'-0"	11'-8"

NOTE 1. The 7400X features the optional 3-bale kit

NOTE 2. Width can be reduced to 8'-6" by folding the deflector

Speed

Tow Vehicle Weight	Empty Processor	Loaded Processor
10000 lb and Under	32 km/h (20 mph)	Not recommended
Over 10000 lb	40 km/h (25 mph)	32 km/h (20 mph)

- The processor features implement tires and hubs and is not suitable for high speed travel
- The processor does not have brakes.
- Slow down for rough conditions, turns, and steep declines.
- If towing long distances, ensure the machine is empty (no bales in tub or on fork)
- If hauling one bale only, place it in the tub instead of on the fork.
- If hauling two or more bales, speed should be further reduced. Note that there will be a significant amount of weight behind the processor axle, causing more "tail whip". This also raises the center of weight of the machine.
- Failure to heed these warnings may result in loss of control or death.



Safety Chain, Jack, PTO, and Hydraulics

- ALWAYS ensure that the safety chain is properly installed. There should be enough slack to allow for turning, but not so much that the chain drags on the ground.
- Ensure that the jack is installed in its storage position on the front tub wall.
- Ensure that the PTO and hydraulic hoses are properly secured
- PTO and hydraulic lines must be connected to the tractor during transport.
- If towing with a pickup, the outer PTO shaft must be removed, and the inner shaft and hydraulic hoses properly secured. The exposed end of the inner PTO shaft should be covered to protect the splines from dust/rocks, etc.

Wheels and Tires

- Check tire pressure and wheel torque. Wheels must be retorqued after 1 hr if being transported for the first time.

Tire Pressure	24 psi	Wheel Torque	125 ft-lb
----------------------	--------	---------------------	-----------

- If transporting long distances, periodically check the tires and hubs for high temperatures. If heating up, you must slow down.

Lights and Marking

- Tow vehicle must have a 7-pin round trailer plug
- Plug in lights and check for proper function and visibility (flashing amber lights, red tail lights and brake lights).
- If towing with a pickup, an adapter will be required to plug into the trailer plug. When braking, both amber lights should activate. Tail lights should always be on.
- Ensure that the supplied SMV (Slow Moving Vehicle) sign is clearly visible from the rear
- Ensure that the reflective markers are cleaned, and visible from all sides

Safety Locks

- Lift the forks all the way up. If carrying a bale, only lift enough for appropriate ground clearance.
- If applicable, the 3-bale clamp should be closed.
- If possible, the deflector should be in the folded position.
- Ensure that the deflector safety lock is installed

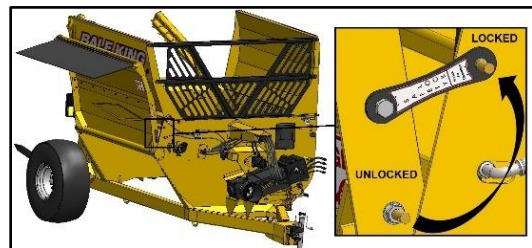



FEATURES & OPERATION

Power Take-off

The Bale King bale processor has a PTO shaft which is splined on both ends. The implement end uses a 1-3/4"-20 spline with locking bolts. Install onto the gearbox and tighten the bolts. The bolts should be torqued to **160 ft-lb** and re-torqued after 8 hrs of use.

The tractor end comes standard with a 1-3/8"-21 spline quick detach constant velocity joint. An optional 1-3/4"-20 spline yoke is available through your Bale King dealer.

The Bale King processor is designed to use a minimum of **100 HP**. The drive shaft is shear-bolt protected. The machine must be operated at **1000 PTO RPM**.

NOTE: *Spread yokes and twisted drive shafts are signs of OVERLOAD, not a manufacturer's defect and therefore not covered by warranty.*

- **DO NOT** operate the machine using a spline adaptor. Use of adaptors will **void warranty** due to damage caused to the tractor PTO, PTO driveshaft, or implement.
- **DO NOT** operate at 540 rpm, or use any kind of adaptor to connect to a 540 rpm spline.
- **ALWAYS** ensure that the PTO shaft is attached securely to the tractor. When the processor is not hooked to the tractor, store the shaft on the PTO holder.
- **DO NOT** transport the processor without securing the PTO shaft. See next page for securing instruction.
- **ALWAYS** ensure that the drawbar is adjusted to **16"** from the end of the tractor PTO shaft to the center of the hole in the drawbar.

Operation

To engage the rotor for processing a bale, be sure the PTO shaft is properly connected to the tractor. Engage the PTO at idle. After the PTO is fully engaged, increase PTO speed until it reaches 1000 RPM.

The processor must not run at any speed less than 1000 PTO RPM as it may result in the flails springing back against the rotor after they come in contact with the bale. This "***backslap***" may cause flails to fatigue and excessive vibration which may cause the bearings to fail. Bales may be dumped into the tub while the rotor is stopped or while it is running.



Shear Bolt

All new Bale King processors are equipped with a **shear bolt** clutch located at the implement end of the PTO shaft. The correct size shear bolt is **3/8 x 2" Fine Thread Grade 5 with Stover Lock Nut**. Any other size or grade will damage the shear assembly. Spare shear bolts are shipped with each new machine and are stored along the front top lip of the tub.

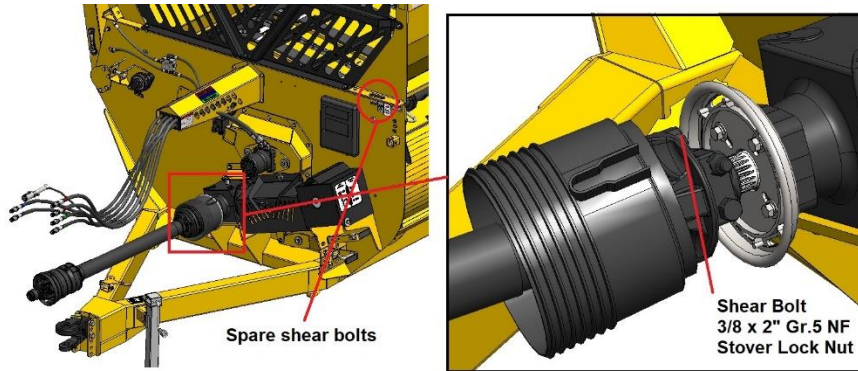

If your shear bolt is shearing excessively, you may be over-loading the machine. If this occurs raise the grate assembly to make the machine less aggressive, or roll the bale more slowly. **Always ensure that your machine is running at 1000 PTO RPM.**

NOTE: *Please consult your local dealer to help pinpoint any problems.*

PTO Holder

A PTO shaft holder is standard with your new Bale King, for safe storage of the PTO shaft when the processor is not in use.

When unhooking the PTO shaft from the tractor, retract and then swing the PTO to the right to rest the PTO on the holder.

DO NOT transport the machine with the PTO in the holder. Slide the outer PTO shaft out and secure elsewhere. When transporting, fasten the inner PTO shaft to the machine and cover the open splined end.

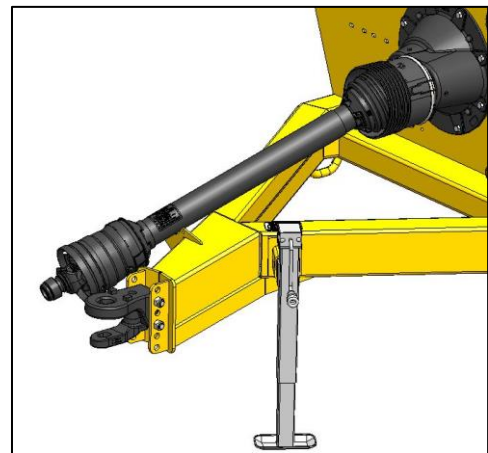



PTO Use and Maintenance

Shut **OFF** the tractor engine and remove the key before doing any maintenance on the machine. Use **ONLY** genuine **Weasler** parts when replacing any worn or damaged PTO components.

Length:

Confirm the minimum and maximum working lengths of the drive-line. The telescoping tubes must overlap at least 1/3 of their length when in use. The PTO is designed to be used with a drawbar length of 16" from the end of the PTO shaft. Adjust your tractor accordingly.

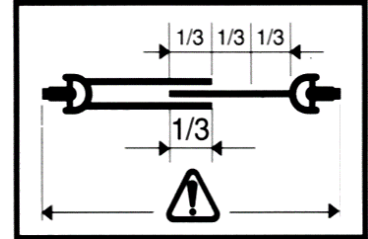

Shielding:

Be sure that the shielding is not damaged and rotates freely on the drive shaft.

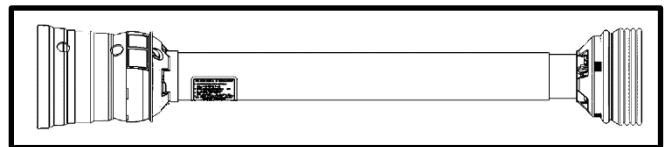

Working Angles:

Constant Velocity joints can operate up to 80 degrees for short periods of time. Do not operate for long periods on sharp angles.

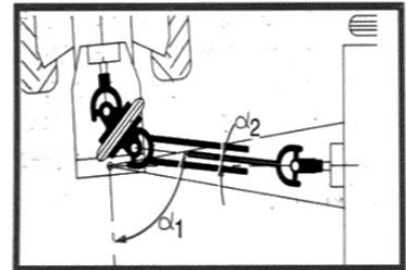

Attachment:

Be sure the drive-line is properly attached and all bolts and screws are tight on the implement input shaft and on the tractor PTO shaft.

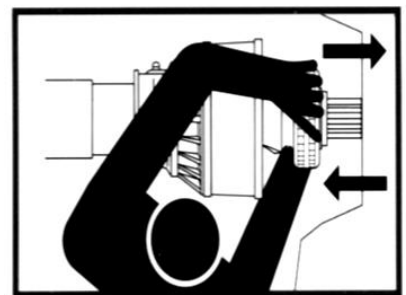

Storage:

When not in use, cover or protect the drive shaft from the weather. When removed from the machine store both halves together to prevent damage. Check all components for proper function and lubrication before use.



**BEFORE ATTEMPTING ANY REPAIR PROCEDURES,
ALWAYS USE APPROPRIATE EQUIPMENT SUCH AS
SAFETY GLASSES, SAFETY SHOES, AND GLOVES**

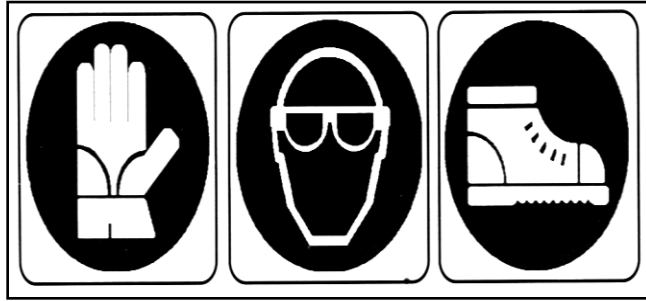

Shield Removal:

- To remove the shield, pop out the red snap, then rotate the guard on the bearing to line up the three tabs with the openings and pull it off away from the knuckle joint.
- Remove the nylon bearing from the shaft by spreading it open.

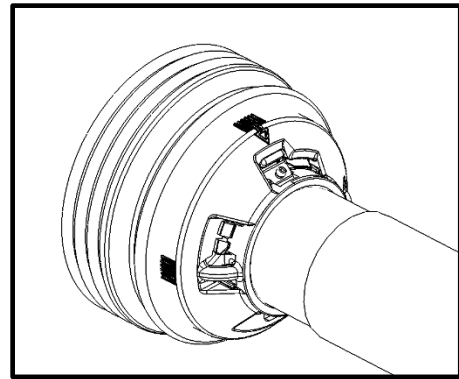

Shield Assembly:

- Be sure to lubricate the groove in the inner yokes where the shield bearing rides. Reinstall shields in the reverse order that they were removed.





Hydraulics

WARNING: Pressurized hydraulic fluid can cause serious injury.

- When working with hydraulic equipment, eye and hand protection should be worn.
- Do not test for leaks with bare hands.
- Relieve any pressure before removing a hose or fitting.
- Never work under components raised by hydraulic equipment unless supported externally.



There are three sets of hydraulic hoses to connect to the tractor. Each hose has a coloured marker to identify its function. They should be connected at best convenience for the tractor's controls. Note that the hoses are paired by colour and the following tables show the operation when pushing oil into the hose with the longer marker.

7400 – 3 Remote	
Long Blue	Lift rear fork
Long Red	Slats towards rotor
Long Yellow	Lift deflector

An optional diverter kit is available to allow the Bale King 7400 to run using only two sets of hoses. The function is then determined by a control box, mounted in the cab of the tractor.

7400	Optional Diverter Kit	33769
-------------	-----------------------	-------

7400 – 2 Remote		
Control Box	<i>“FORK”</i>	<i>“DEFLECTOR”</i>
Long Blue	Lift rear fork	Lift deflector
Long Red	Slats towards rotor	

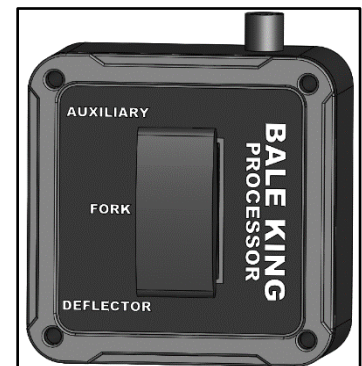

Maintaining proper slat speed ensures consistent and smooth feeding of the bale into the rotor. Refer to page 18 for more information on setting the machine.



An optional 3-bale kit is available to allow the Bale King 7400X to carry an extra bale on the rear of the machine (see page 26). If this kit is installed, an additional clamp is added to the hydraulic functions. This changes the hydraulic setup as shown in the following table.

7400X – 2 Remote			
Control Box	<i>“AUXILIARY”</i>	<i>“FORK”</i>	<i>“DEFLECTOR”</i>
Long Blue	Clamp bale	Lift rear fork	Lift deflector
Long Red	Slats towards rotor		
7400X – 3 Remote			
Control Box	<i>“FORK”</i>		<i>“DEFLECTOR”</i>
Long Blue	Lift rear fork		Lift deflector
Long Red	Slats towards rotor		
Long Green	Clamp bale		
7400X – 4 Remote			
Long Blue	Lift rear fork		
Long Red	Slats towards rotor		
Long Yellow	Lift deflector		
Long Green	Clamp bale		

Hose Holder

The hydraulic hoses may need to be adjusted to avoid damage from rubbing on the PTO shaft. This can be done by lifting or lowering the hose holder. Loosen the pin handle, then lift the end of the hose holder to drop the pin into the slot. Then adjust the height as desired and catch the pin into the desired notch. Finally, retighten the pin handle to prevent it from switching positions if the machine bounces.

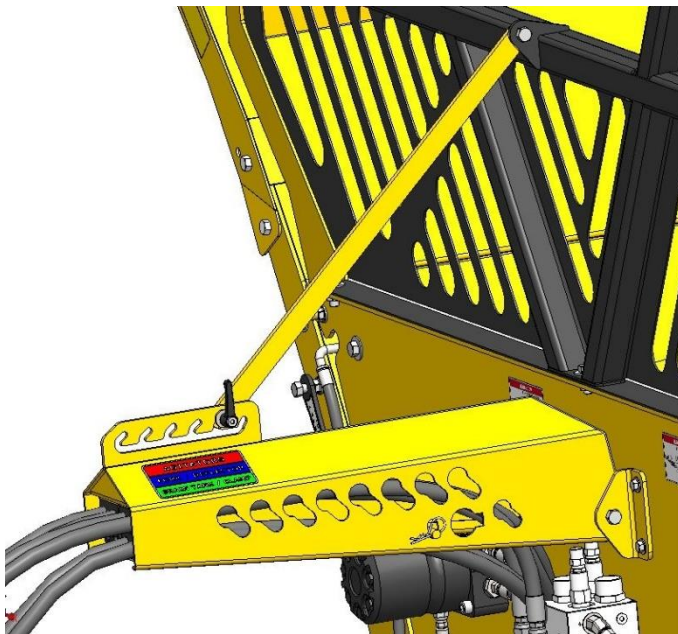

- Loosen handle
- Lift end of holder
- Slide pin in slot
- Choose setting
- Tighten handle

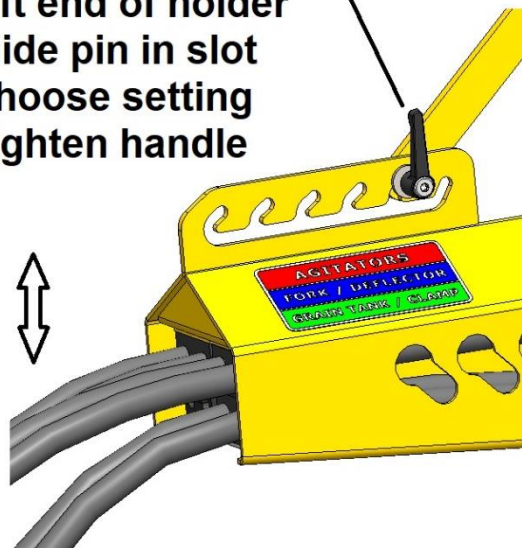



Implement Tongue

The adjustable hitch on the Bale King features a cast single tongue with optional clevis insert (**BMI #29786**). This allows for use with tractors equipped with a hammer strap or with a single drawbar. It also allows the machine to move independently over rough terrain without bending the draw pin.

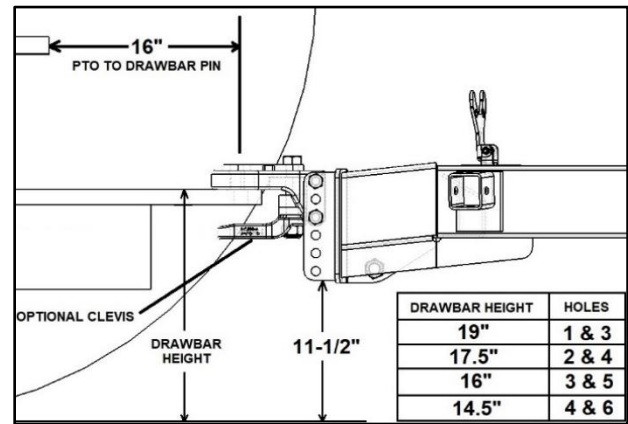

- Make sure that the drawbar is set to **16 inches** behind the PTO shaft for proper PTO length.
- Measure the drawbar height of the tractor and adjust the machine tongue height to the closest match. This will ensure that the PTO runs as straight as possible.
- **DO NOT** install the optional clevis if using a tractor with a hammer strap as this will bend the hitch pin.
- **ALWAYS** connect the safety chain during road transport

Rear Fork

The rear loading fork tines can be adjusted side to side by removing the pin connecting the tine to the machine and replacing the tine in the other available gap. The widest position is recommended for all situations, except for the smallest bales. Always use tines in the same position on either side to keep the load on the forks and cylinders balanced.

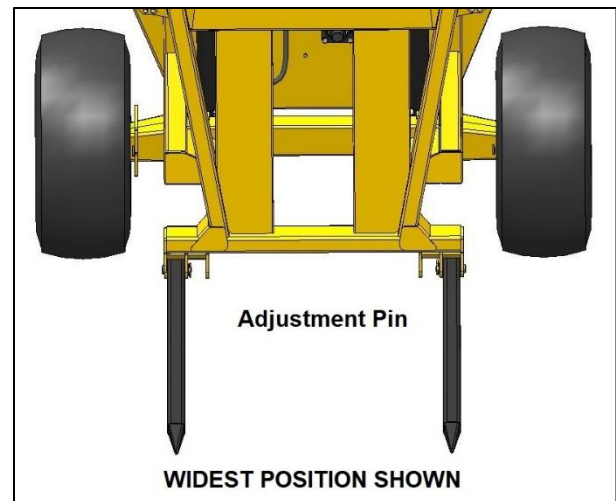

For transport, and safety when working under the forks, the Bale King 7400 is equipped with hydraulic safety valves that do not allow the forks to come down without hydraulic pressure. Lowering the forks using the tractor controls overrides this valve and allows the forks to fall. Never stand under the forks. When greasing or servicing around the rear end, the forks should be down. Never attempt to loosen or replace hydraulic hoses while the forks are up.



Loading Bales



When loading bales into your Bale King bale processor, the following procedure should be followed:

- Position the tractor and the Bale King so as to be lined up to back straight into the row of bales.
- When close to the bale, lower the forks completely (you will feel a light vibration as the forks bottom out against the frame.)
- Back completely under the first bale.
- Allow the tractor to move forward while lifting the bale, because the bale fork moves away from the machine while loading.
- If you are loading from the same row you can dump the bale into the machine and back straight into the second bale. If you are going to a different stack for the second bale only raise the first bale enough to clear the ground. Move to the next row and align the machine to the bale before dumping the bale into the tub. This gives you good visibility to line up to the second bale.
- Once you have the first bale in the tub and the second bale on the forks, raise the bale fork about 1/4 of the way up. You can now transport to your feeding or bedding area to begin processing.

Note: *Carry the bale as low as possible to lessen the stress on the cylinder shafts. Carrying the bale too high may bend hydraulic cylinder shafts.*

- When the first bale has been processed, it is common practice to **leave the rotor running at full speed** when loading the second bale into the bale chamber from the rear forks. **The chain should be stopped during loading.**

For information on the optional 3-bale kit, see page 26.



Deflector

The Bale King 7400 is equipped with a hydraulic side deflector to change the discharge distance and distribution. It also comes with a flipping rubber flap for superior control of the spread pattern.

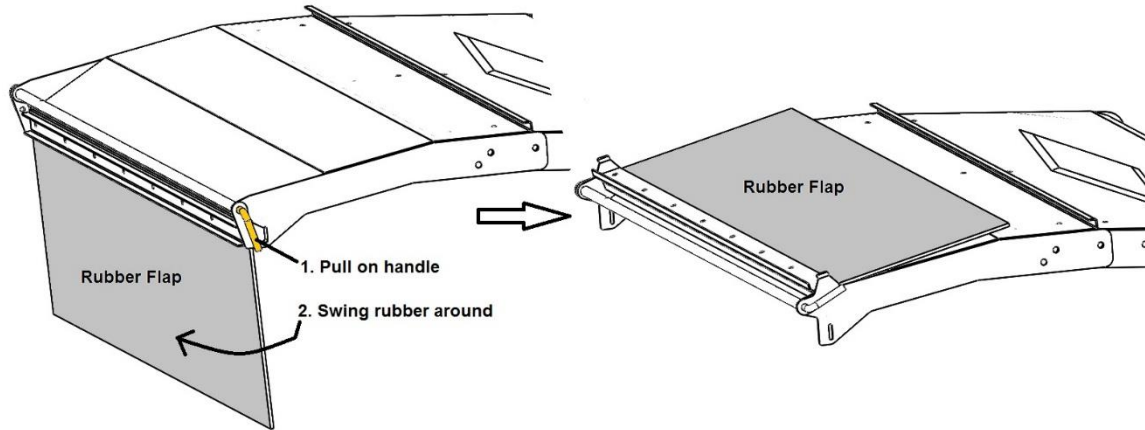

Moving the deflector to the **down** position and flipping the rubber down (above left) will allow the hay to be laid in a windrow, or bunk feeder. Swinging the deflector **up** will allow you to spread straw out over a large area. If you also flip the rubber up (above right), you will be able to aim the discharge, to control the height and distance.

To flip the rubber, simply pull on the handle and swing into position. Then push the handle so that the tabs catch in the notches and lock into place.

The Bale King 7400 deflector will bunk feed to a distance of 32" from the tire when in the lowest position. When the deflector is not folded, the transport width of the machine is 9'-1".



For transport and storage, the deflector lock should be put in place by swinging the lock as shown and fastening with a lynch pin.

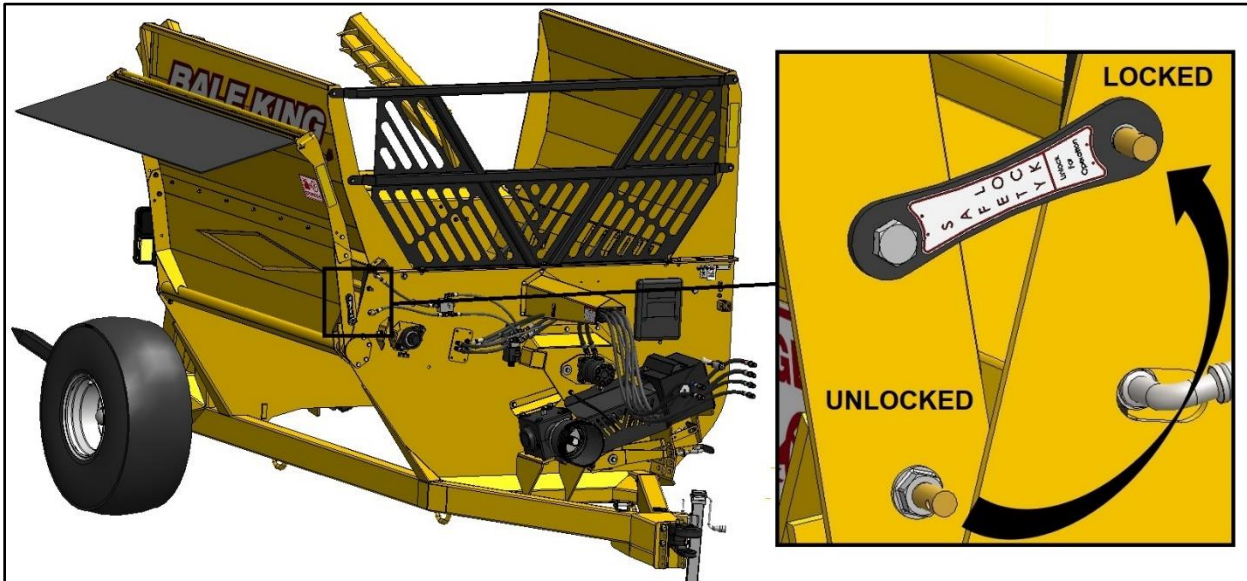

The Bale King 7400 deflector also has the ability to fold for more compact long-term storage or long-distance transport.

- Move the deflector to its lowest position
- Remove the 7 top carriage bolts from the deflector. Set aside for later.
- Remove all 4 bolts on the front and back of the deflector. Slide the outer deflector outward until the second set of holes align. Bolt together loosely.
- Raise the deflector with the hydraulics. Fold the outer deflector down until the third set of holes line up. Install and tighten all four bolts.

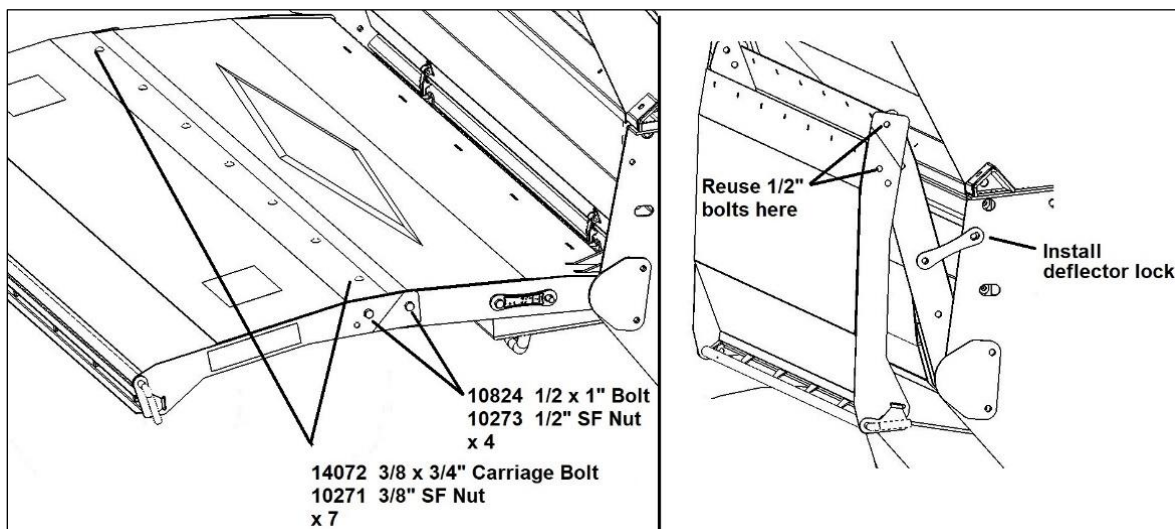

BE CAREFUL WHEN LIFTING THE DEFLECTOR WITH THE OUTER PANEL ABLE TO PIVOT TO AVOID CONTACTING THE TIRES.



Lower Deflector

The 7400 processor also features an adjustable lower deflector. This allows the operator to change how high the material is discharged. The higher setting will allow for further spread pattern of bedding, or to shoot material upward to clear a bunk feeder. Lower settings are recommended for windrow feeding, as well as heavy wet material. This will reduce the chance of plugging. To adjust the lower deflector, use the handle closest to the tub beneath the gearbox.

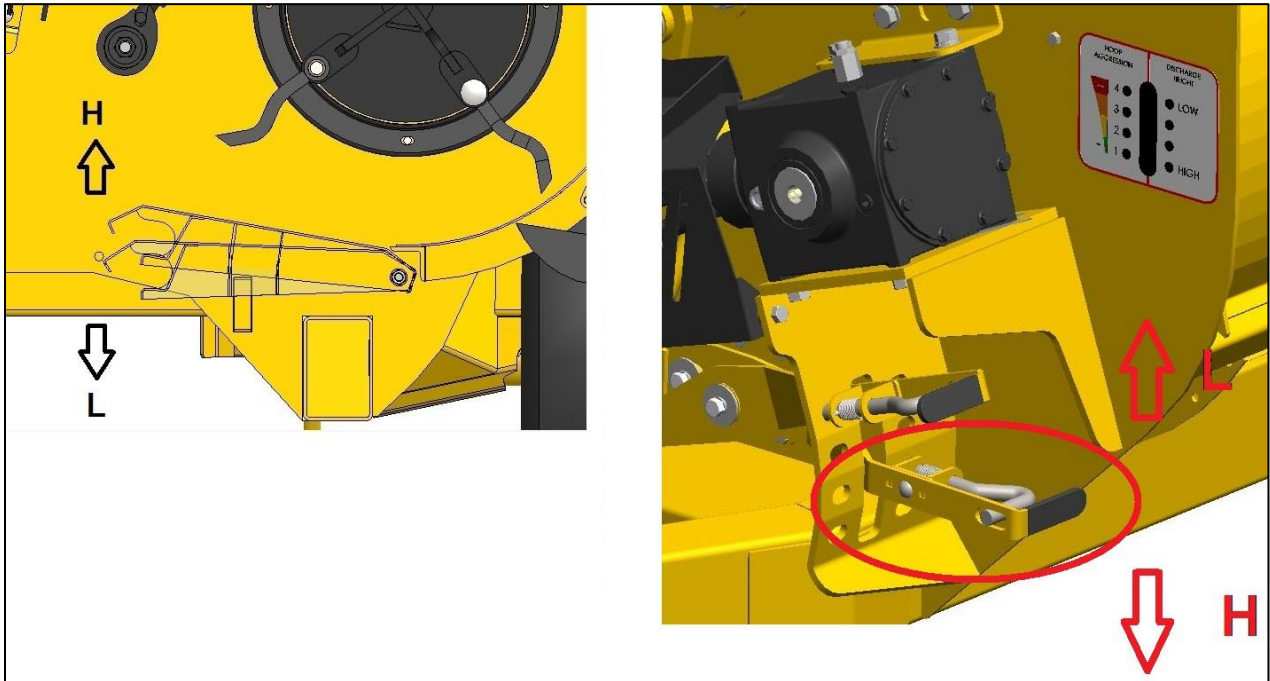



Setting the Processor

Processing speed must be balanced with overall aggression and vibration levels. Excessive continuous vibration may affect the service life of the processor.

Processing times of 1-2 minutes are considered normal in dry bale conditions. Extended times are expected in tougher conditions such as high moisture feed, frozen, or misshapen bales. *The processor may need to be adjusted for each type of bale for optimal performance.*

QUICK SET-UP SUMMARY (See subsequent sections for further details):

1. Chain Speed
See page 19
100 – 140 RPM (120 recommended)
Increase to improve bale rotation and throughput
Decrease to reduce vibration and increase chain life

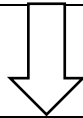

2. Upper Hoop Setting	3. Lower Hoop Setting
See page 21	See page 21
Affects processing speed while bale is between 25 – 100% size	Affects processing speed of the core of the bale
Recommend position C as starting point	Recommend position 2 as starting point
Lower hoops to increase throughput and improve bale rotation (A -> D)	Lower hoops to increase throughput (1 -> 4)
Raise hoops to reduce vibration (D -> A)	Raise hoops to reduce vibration (4 -> 1)

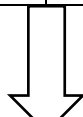

4. Hoop Quantity	5. Hoop Type
11 Hoops are standard	7 Low Profile and 4 High Profile Hoops are standard
If desired throughput cannot be achieved via chain speed and hoop height adjustment, remove the middle 3 low profile hoops (leaving 3 high profile and 4 low-profile on 10" centers)	If desired throughput cannot be achieved via all above adjustments, remove the 3 high profile hoops and replace with the 3 standard profile hoops previously removed (total of 7 low profile hoops).
If vibration is excessive, 2 extra hoops can be purchased and installed	If vibration remains excessive after all above adjustments have been made, high profile hoops can be purchased and installed in lieu of the 7 standard profile hoops.



Chain and Slats

The hydraulic chain and slat table feeds the bale into the rotor. Chain speed is one of the primary feed rate and aggression controls.

Operate the conveyor clockwise (as viewed from the tractor) causing the bale to rotate counter-clockwise in normal operation. Reverse the chain as necessary to clear slugs.

Typical chain conveyor shaft speeds are 100-140 RPM. The speed is controlled by the tractor flow control valves or an optional processor-mounted flow control valve kit (see page 30).

It is best practice to start at a slower speed, and gradually increase until desired performance is achieved. Excessive chain speed will cause premature wear.

Plastic guides are bolted to the bed underneath of all the slats to prevent wear. Inspect the slats and plastic guides periodically. Replace as necessary.

It is good practice to run the chain in reverse for momentarily at the end of each day to clear loose material and/or snow from the lower chain return pan.

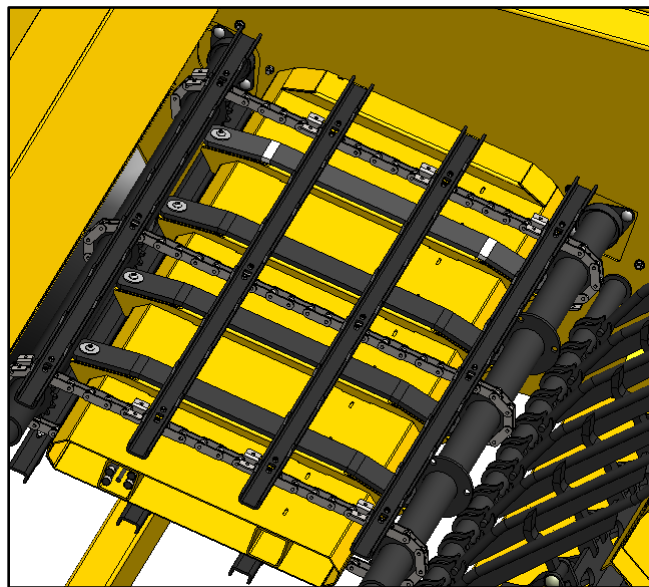
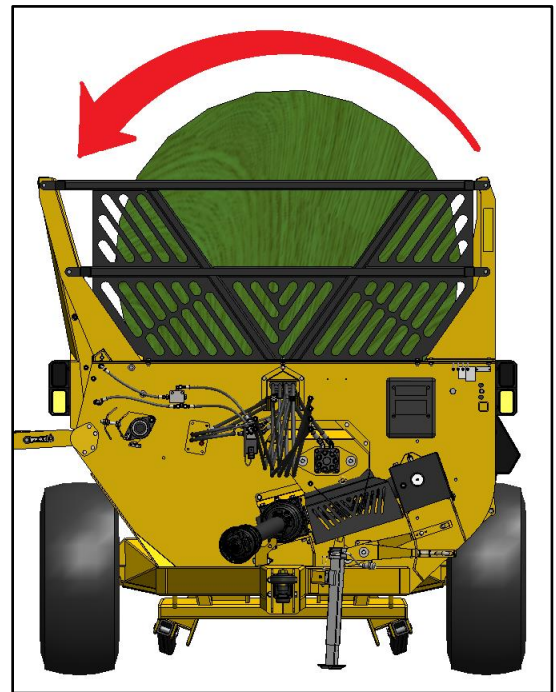



Chain Adjustment

The chain tension can be adjusted using the threaded rods on the front and rear of the tub. The bearing bolts must be loosened before the adjustment is started, then re-tightened after desired tension is achieved.

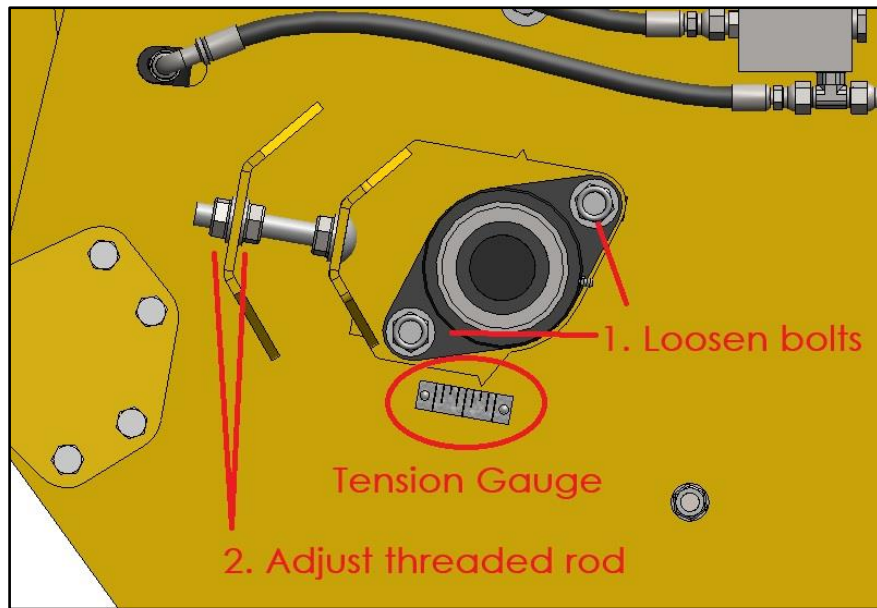

The chain tension should be checked front and rear. When lifting the slat nearest to the center between the drive shafts (by hand), the slat should lift by about 3/4" (roughly finger width) off of the plastic slider. There is also a gauge provided so that both sides can be adjusted evenly. It is best practice to use the same setting on both sides.

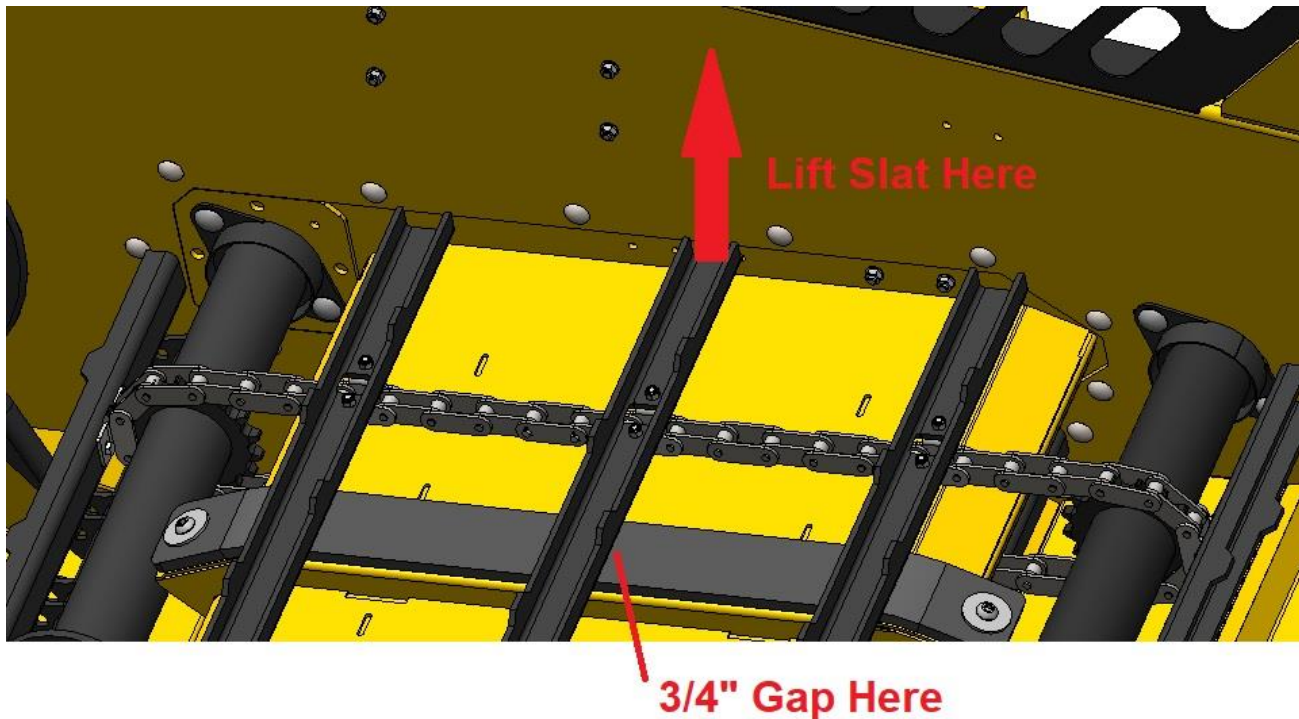



Hoop Grate Adjustment

The hoop grate controls the flow of material into the rotor. Along with chain speed, this is the primary feed rate & aggression control. Both the top and the bottom of the hoop bars can be adjusted independently to optimize feed flow. Hoops can be added or removed (subject to limitations described below) to further optimize performance.

Top Hoop Adjustment

The top hoop adjustment controls the feed rate of the majority of the bale (while bale is approximately 25%-100% of full size). There are 4 positions on the spring-loaded adjust lever on the left side of the processor. Aggression increases from A to D.

To improve throughput and bale rotation, move the lever from A towards D. Best practice is to increase aggression one position at a time and then process a bale as a test before any further adjustment.

To reduce noise and vibration, reduce the top hoop aggression from D towards A. Excessive vibration may break the PTO shear pin and reduce the life of the rotor and driveline components.



Lower Hoop Adjustment

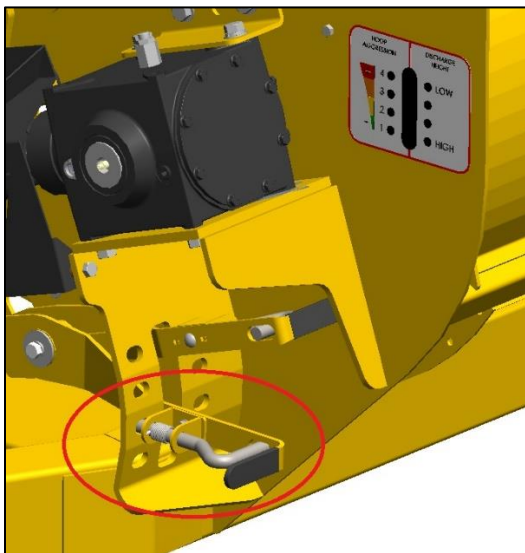

The lower hoop adjustment controls the feed rate of the core of the bale (when the bale is approximately 25% of full size or less). There are 4 positions on the outer spring-loaded handle on the front left corner of the processor. Aggression increases from position 1 to position 4.

If vibration is excessive on the core, reduce aggression from 4 towards 1.

If higher throughput is desired, increase aggression from 1 towards 4.



Number of Hoops

The Bale King 7400 is designed to run with a minimum of 7 hoops (10 inch spacing) to a maximum of 13 (5 inch spacing). Do not exceed 10 inch spacing.

From the factory, 11 hoops are installed. 7 low profile hoops at 10” spacing plus 4 high profile hoops in the middle of the processor. This combination is suitable for a wide range of bale conditions.

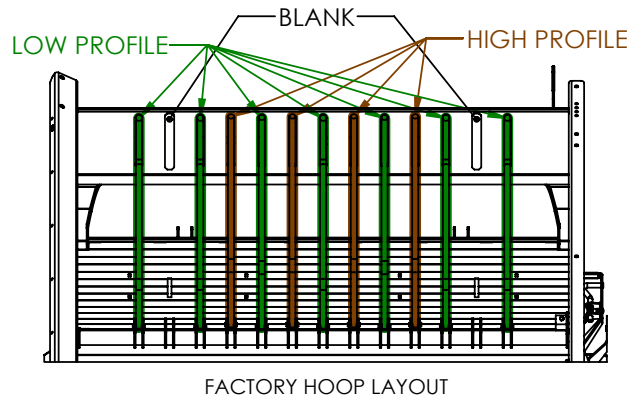

To increase throughput in dry conditions beyond what can be achieved via standard chain speed and hoop height controls (subject to overall vibration levels), remove 3 of the low-profile hoops and one of the high-profile hoops in the center of the machine (*leaving 4 low profile and 3 high profile hoops evenly spaced at 10” centers*) across the rotor. Reposition the high hoops to maintain 10” centers. Fine tune by adjusting the chain speed and hoop height settings.

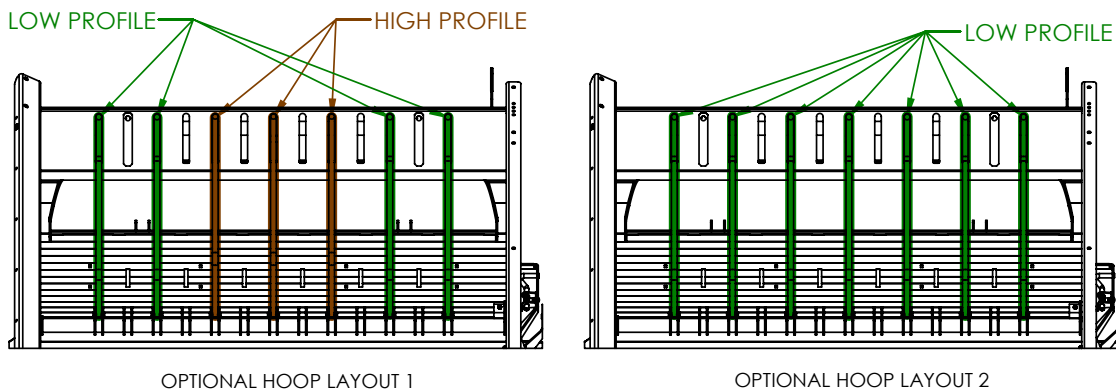

If further throughput is desired (subject to overall vibration levels), remove the 3 high-profile hoops and replace with the previously removed 3 low-profile hoops (*end result is 7 low-profile hoops evenly spaced on 10” centers*). Fine tune by adjusting the chain speed and hoop height settings.



To reduce aggression over factory settings beyond slowing the chain and raising the hoops, 2 additional hoops can be purchased and installed for a total of 13 hoops. Alternatively, the low-profile hoops can be replaced with high profile hoops for improved control.

7400	Additional Low Profile Hoop	33746
7400	Additional Low Profile Hoop Package (includes clamp)	33833
7400	Additional High Profile Hoop	35197
7400	Additional High Profile Hoop Package (includes clamp)	35249
7400	Additional Hoop Plug Package	35248

To remove hoops, follow the steps as outlined below:

1. Lower hoops fully (handle to highest setting)
2. Remove the top hoop clamp (2 x 3/8" bolts)
3. Swing the top of the hoop into the tub.
4. Lift the hoop out of the tab on the lower pipe.
5. Remove hoop from tub and store for later.
6. Install hoop plug over the exposed hole. Fasten with retainer clip and nut.

To install hoops, reverse the above steps.

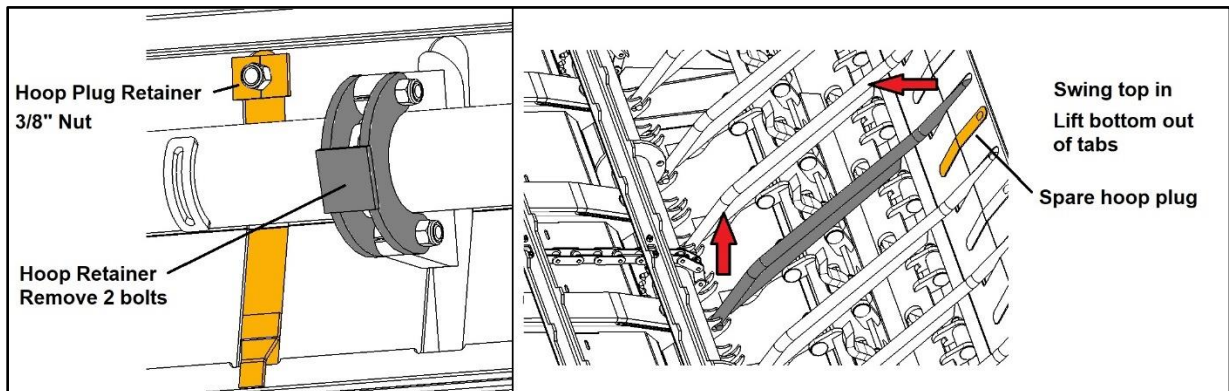



Optional Diverter Kit

The Bale King 7400 processor has an optional diverter kit which allows it to operate using only 2 hydraulic remotes. The fork and deflector functions are then controlled by a cab-mounted switch box. This box must be wired up to the tractor. You may use the provided plug to plug into the accessory outlet. If this is not available, the plug can be disassembled, and wired as necessary.

Black Wire	White Wire
+12V (Ignition Switched)	-12 V / Ground

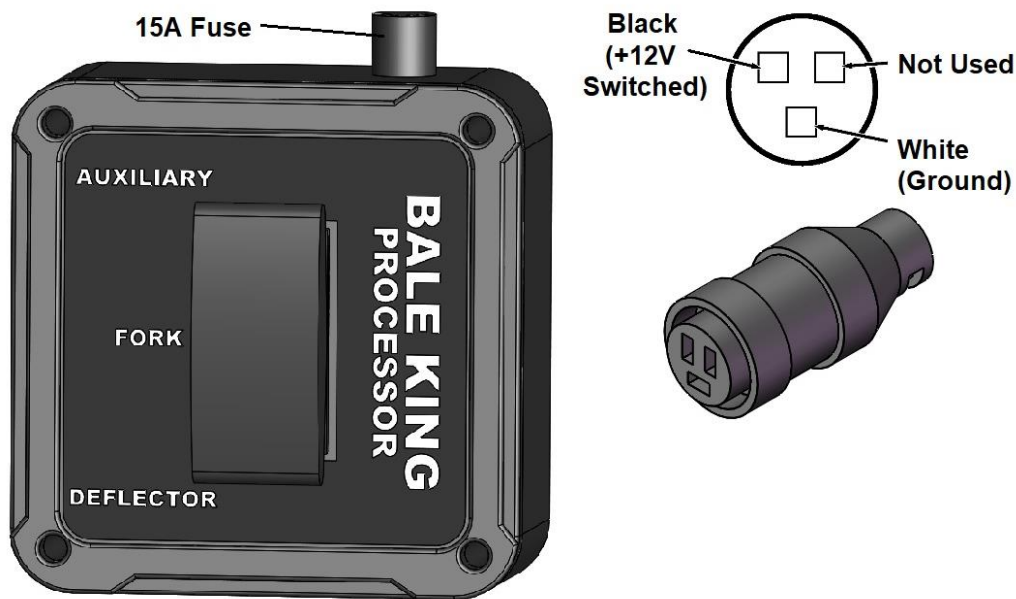

7400	Diverter Kit (3 – 2 Remote)	33769
7400X	Diverter Kit (4 – 3 Remote)	33771
7400X	Diverter Kit (4 – 2 Remote)	33772

A 4-pin plug is used to power the diverter valve on the processor. Route the plug to the rear end of the tractor so the trailer end can be plugged in. If no power is supplied, the hydraulics will still control the rear forks, but the deflector will not be functional. If the switch in the tractor is activated, the deflector can be controlled. On 7400 machines with the option, this box can also control the 3-bale clamp (as “Auxiliary”).

The diverter kit also features a pilot operated check valve to ensure that the deflector will not fall down due to leaking across the valve.



Optional Fine Chop Kit

The Bale King 7400 processor has an optional fine chop knife kit available to go into the lower tub area. This option is available if you require a finer cut on the material which you are processing such as slough hay and silage bales.

7400	Optional Fine Chop Kit	33773
------	------------------------	-------

It is recommended that the knives be lowered when bedding straw as it will affect your spread pattern. Adjust the machine as needed.

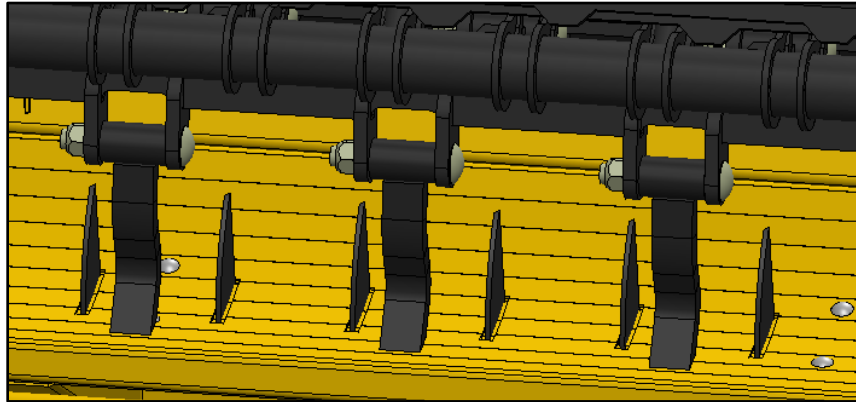

There are two settings for the fine chop, depending on how fine you wish to cut the material. These settings are achieved by pulling on the handle (towards the back of the machine), then selecting the desired hole.

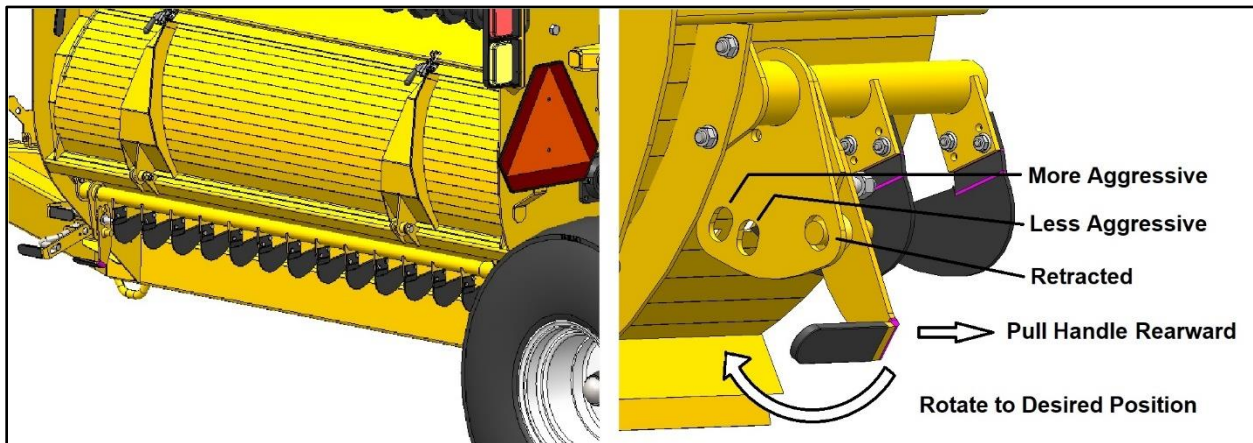



Optional 3 Bale Kit (7400X)



7400X	Optional 3-Bale Kit	33697
-------	---------------------	-------

The Bale King 7400 has an available attachment kit which increases the carrying capacity of the processor by 50%, while maintaining the easy maneuverability of the two-bale processor. The attachment kit stores the second loaded bale behind the first and above the third in a set of powerful hydraulic clamps.

The 3-bale kit changes the loading process of the bale processor slightly. The loading of the second bale involves lifting the bale so the fork and bale are parallel to the ground, or just above this point. The clamp can be closed around the bale at this point and the fork then lowered back to the ground. The third bale can then be backed under and lifted until it is lightly supporting the second bale. After the first bale processing is complete, the clamp can be opened (while the third bale is supporting the second), and the fork can be lifted until the third bale pushes the second into the tub.

An optional back-up camera (page 31) is available to aid in the loading process by giving the operator direct visibility of the loading forks, even with a bale in the tub. See the next section for more information.



3 Bale Kit Loading Sequence:

1. Position the tractor and the Bale King so as to be lined up to back straight into the row of bales.
2. Ensure the bale clamp is opened fully.
3. When close to the bale, lower the forks completely (you will feel a light vibration as the forks bottom out against the frame).
4. Back completely under the first bale.
5. Lift the first bale, allowing the tractor to roll forward slightly while lifting the bale. This is because the lifting fork moves away from the machine slightly when loading.
6. If you are loading from the same row, you can dump the bale into the machine and back straight into the second bale. If you are going to a different stack for the second bale, only raise the first bale enough to clear the ground. Move to the next row and align the machine to the bale before dumping the bale into the tub. This gives you good visibility to line up to the second bale.
7. Once you have the first bale in the tub and the second bale on the forks, raise the second bale until it presses on the bale in the tub and then lower it until the fork is approximately horizontal or just above. Raising and then lowering the bale puts it in the optimal position for clamping and clearance on the bottom bale.





8. Once the bale is in the appropriate location, close the clamp fully and then lower the lifting fork.
9. Back under the third bale and lift the forks until the third bale is lightly supporting the second bale. You will see when to stop lifting as the clamped bale will tilt forward slightly.
10. When the first bale has been processed and the third bale is still lightly supporting the second, open the clamp to release the second bale. Once the clamp is opened, lift the fork until the third bale pushes the second bale into the tub.
11. Once the second bale is processed, the fork can be fully lifted to load the third bale into the tub.





Lockout Mechanism Adjustment and Setting

The 3 Bale Kit is equipped with a lockout mechanism that prevents damage to the clamps if the fork is lifted before the clamps are released. The lockout mechanism works by allowing the clamps to “break-away” if contacted, or if a bale in the fork pushes too hard on a clamped bale. When this happens, a valve is activated which locks out the forks and prevents them from lifting any higher. To reset, lower the bale slightly to release the valve, then open the clamps.

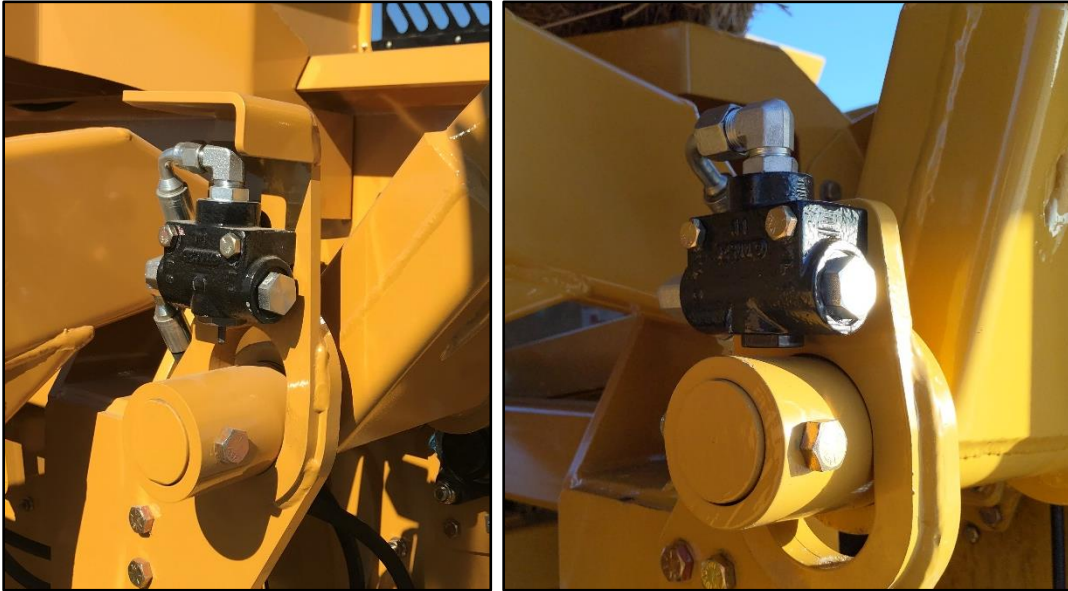

Clamps lift up in slot, activating the valve. Lowering the forks resets this.



Optional Flow Control Valve

The Bale King 7400 processor has an optional flow control valve to control the speed of the chain and slats if it is not possible to control this directly from the tractor. Rotate the lever left or right to slow or quicken the speed of the chain.

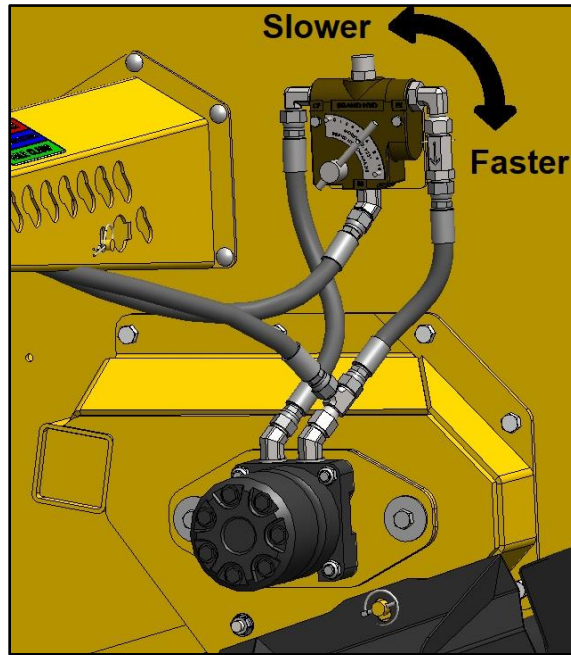

7400	Optional Flow Control Valve	33767
------	-----------------------------	-------

The speed should be adjusted so that the bale makes one full revolution in 8-12 seconds. This corresponds to a shaft rotation of 80-120 rpm, or 120 to 180 slats per minute. When adjusting the speed, make sure that the tractor is running at PTO RPM.



Optional Back-up Camera

The Bale King 7400 processor has an optional back-up camera to provide increased visibility while loading bales. This is especially helpful when combined with a 3-bale kit.

7400	Back-up Camera Kit (Standard)	32619
7400X	Back-up Camera Kit (Pro)	32628



There are two versions of the kit.

Standard Kit	Pro Kit
Camera Rated to -20°C (-4°F)	Camera Rated to -40°C (-40°F)

The kit includes a mounting bracket to install the camera on the rear axle of the processor, as well as cables to run to the tractor. The monitor can be installed in the tractor cab, with a plug between the tractor and processor.



SERVICE AND MAINTENANCE

Greasing and Lubrication

Greasing of the Bale King processor should be done on a regular basis.

Every 50 bales			
C	Rotor Gearbox	1	3-5 pumps
Every 150 bales			
A	Bale Fork Pivot	2	3-5 pumps
B	3 Bale Kit Arm Pivot	2	3-5 pumps
D	PTO Cross & Bearings	3	5 pumps
	PTO Guard Bushings	2	5 pumps
	PTO Spline	1	8-10 pumps
	PTO Spline	4	2-3 pumps
Every 500 bales (or annually)			
D	PTO CV Joint	1	30 pumps
E	Chain Table Bearings	4	3-5 pumps (DO NOT OVERGREASE)
F	Rotor Bearing	1	3-5 pumps (DO NOT OVERGREASE)
G	3-Bale Kit Cylinder Eye	2	3-5 pumps
H	Jack	1	8 – 10 pumps
Annually			
I	Wheel Hubs	2	Pack hubs full

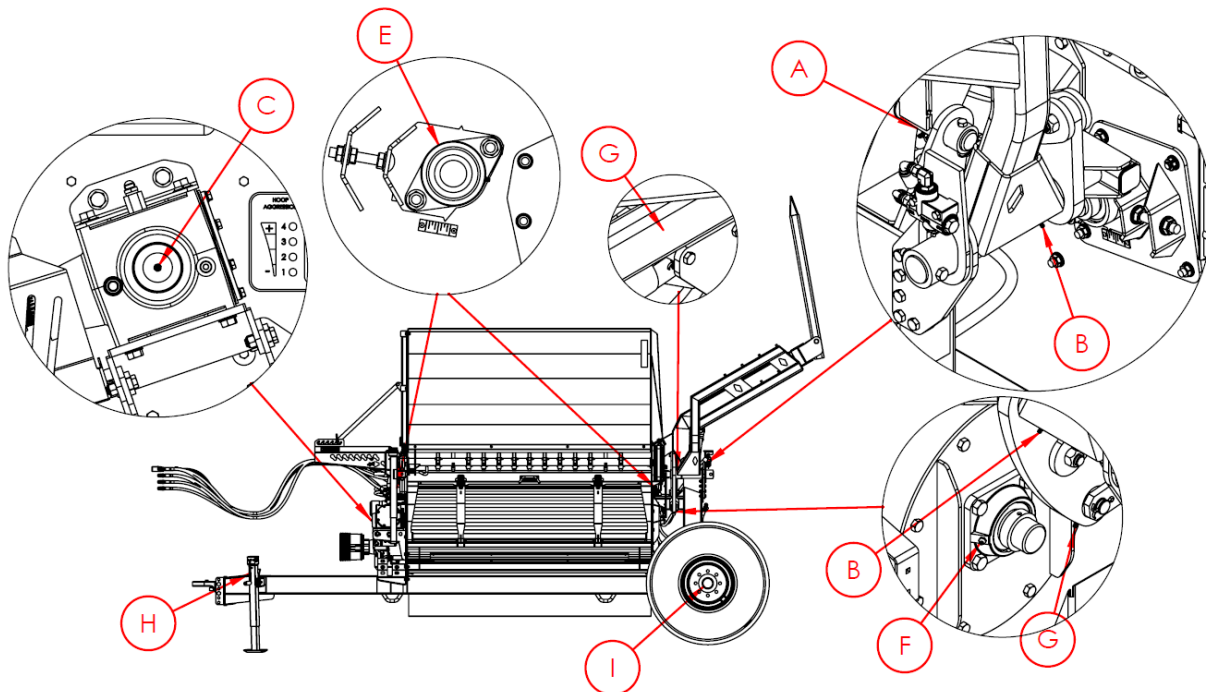



PTO/Driveline

The Bale King 7400 features two PTO shafts. One connecting to the tractor, and one between the gearboxes. Frequent lubrication is required. Grease the driveline parts as required on the chart. The guards must be removed for access.

All zerks can be accessed while the PTO is connected to the tractor EXCEPT for the telescoping spline, which can only be accessed when the PTO is fully retracted.

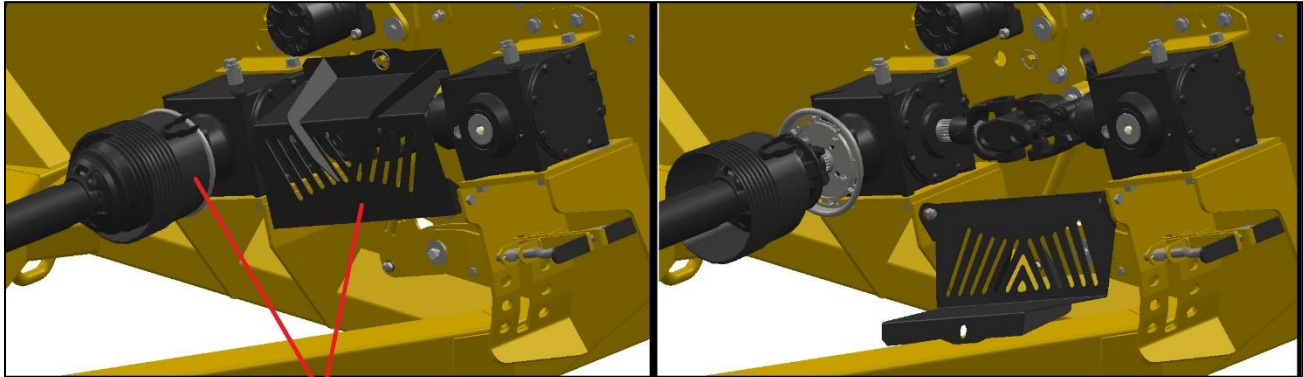

GUARDS MUST REMAIN IN PLACE DURING OPERATION

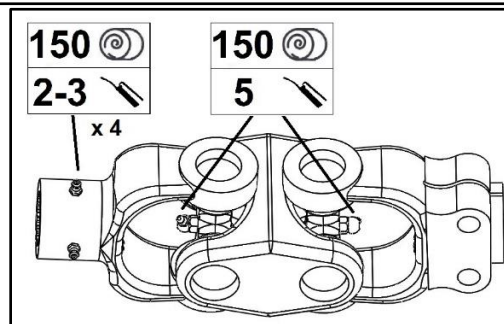
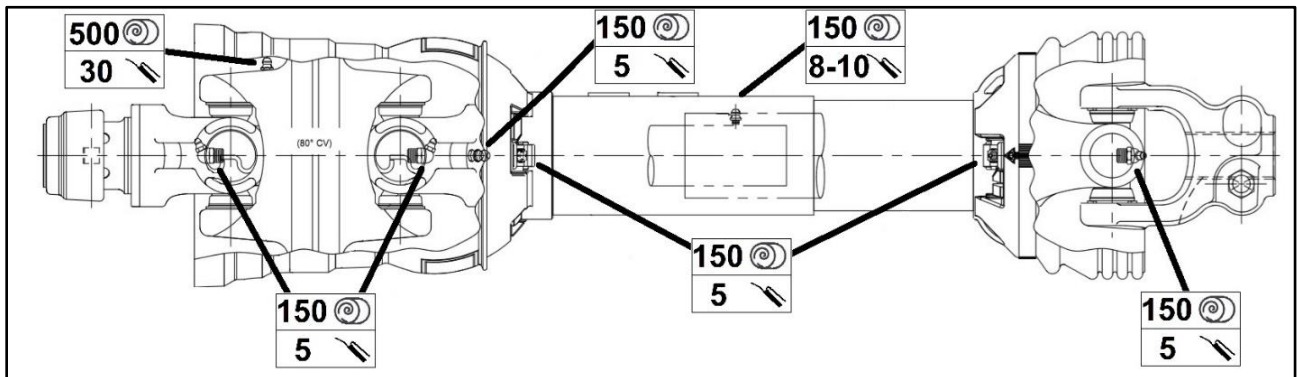

After storage for long periods of time, lubricate and check the function of every driveline component before operating.

Failure to grease all the joints will **VOID** warranty.



Gearboxes

There is one grease zerk on the front of the outer gear box. Apply 3-5 pumps of good quality grease every 150 bales.

If the gearbox is removed to replace the rotor or perform any other service, add **150 pumps** of grease to the grease zerk upon reinstallation.

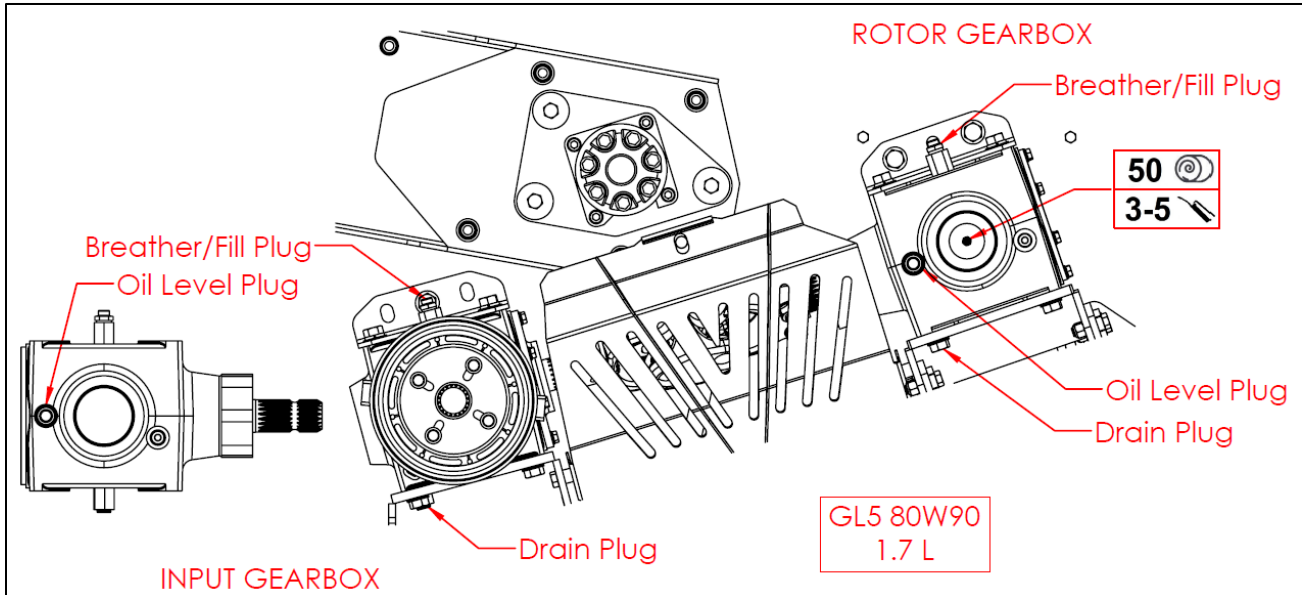

The gearboxes require GL5 80W90 gear oil. The gearbox should be filled to the level plug (approximately **1.7 L**) and checked on a regular basis. Check the breathers for any oil spillage. The oil should also be changed at the following intervals:

- 500 bales after first use
- 2000 bales after first use
- Every 5000 bales afterwards (or every 2 years, whichever comes first)

Chain

The bale turning chains should be lubricated every 500 bales or annually (whichever comes first).

Apply graphite chain lubricant spray to both sides of each chain connection.

Inspect the sprockets and plastic wear strips for excessive wear. Inspect the slats and straighten or replace any bent ones.

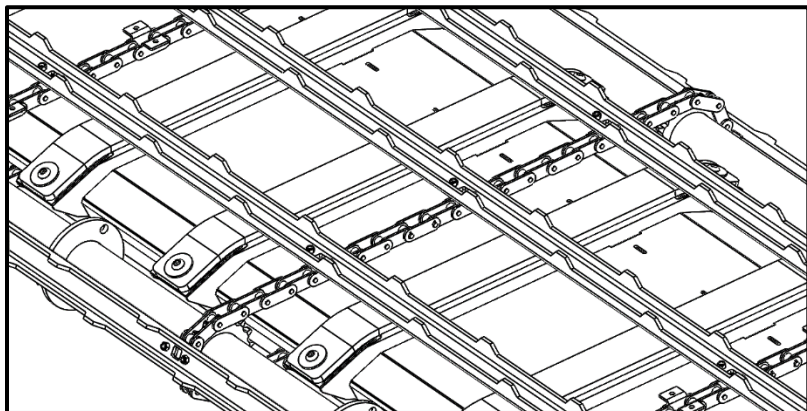



Cylinder Maintenance

The hydraulic cylinders are easily removed for repair or maintenance simply by:

- Lowering the fork (or deflector) to the down position and unhooking the hydraulic lines. Be sure there is no pressure on the lines and mark the line locations so there is no confusion when reinstalling the cylinders. Check hydraulic schematics.
- Removing the cotter pin closest to the frame of the machine and sliding the cylinder pins out
- To reinstall, reverse the removal procedure

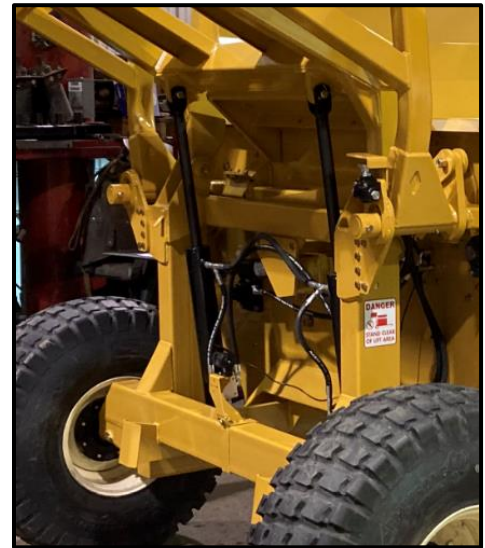

NOTE: *Always cover exposed cylinder shafts with grease to avoid rusting of shafts if the unit is not used for extended periods of time. Rusted cylinder shafts are NOT covered by warranty*

NOTE: *Check all hoses and fittings periodically for leaks. Tighten or replace any dripping components or any worn out hoses.*



Tires

Wheel bearings should be inspected annually for adjustment and lubricated annually. Inspect more often for extensive traveling.

- To tighten the wheel bearings, lift up each wheel (one at a time) until the wheel spins freely.
- Remove dust cap and the cotter pin which retains the castle nut.
- Tighten the nut until the wheel will rotate approximately two turns when given a firm spin.
- Align castle nut to closest hole and insert the cotter pin.
- Pack hub full of grease and reinstall the dust cap.

Proper tire inflation will help to alleviate puncture problems when towing and operating on rough terrain.

Check for proper tire inflation	24 psi
Replace any damaged or worn tires	16Lx16.1 8-ply
Check and tighten wheel bolts on a regular basis	125 ft.lb

Note: Warranty does not cover damaged rims and hubs due to loose wheel bolts or flat tires. Tire warranty is covered by the tire manufacturer.



Note: When inflating tires, use a clip-on chuck and extension hose long enough to allow you to stand to one side and NOT in front of or over the tire assembly.



Twine Removal

It is natural that twine that has been removed from the bales will wrap around the rotor. It is recommended to remove the twine from the rotor every 10-15 bales to avoid having so much that it begins to hinder the flail movement. The more often this is done, the easier it is to remove, since the twine has not had a chance to wrap more tightly. The patented “X” shape makes twine removal much easier.

To make this process even easier, an access door is available for easy access to the rotor. This is found on the left side of the machine and is opened and closed using the over-center latch at the top of the door. Always make sure this door is properly closed while operating.

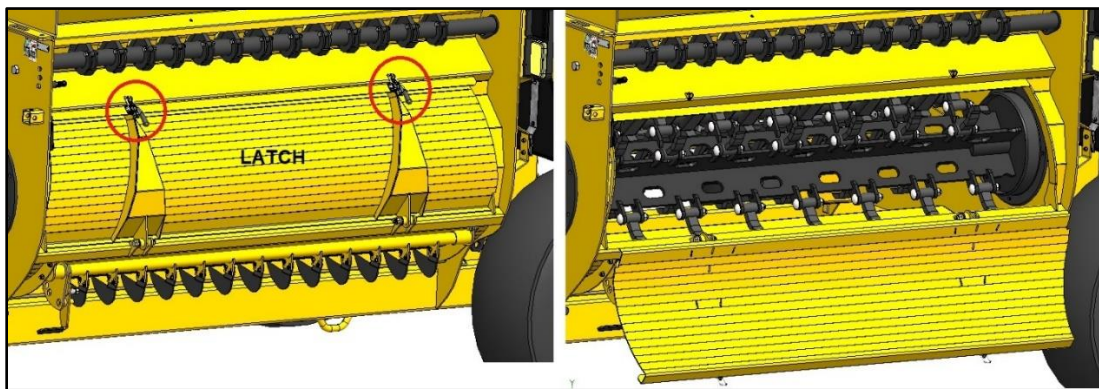

WARNING: Before attempting the removal of twine from the rotor, be sure that the machine is stopped and the tractor is shut **OFF**. Place the tractor in park. Twines can be removed with the use of any knife. Cut the twine/net along the full length of the rotor, then pull this twine out of the machine and dispose of it.

An electric device is also available from suppliers to melt the twine & allow it to be pulled off. Twine/net combined with hay dust is extremely flammable. **NEVER** leave the machine unattended until all twine, dust, and embers have been removed. It is **NOT PERMITTED** to leave the twine burning on the rotor as this has several adverse effects:

- It may take the temper out of the steel, rendering it weaker.
- Loose straw and hay remaining in the machine may ignite causing a fire in the processor.
- Excessive buildup of melted plastic.
- Dry out bushings causing them to wear prematurely.

NOTE: Bridgview Manufacturing Inc. VOIDS warranty for any damage caused by twine burning in the processor.



Twine guards are also installed on the machine to keep bale twine out of important areas such as bearings. They should be checked for twine wrap periodically.

- The wheel hubs have a twine guard to keep anything from getting tangled in the wheel bearing. Check for and remove any twine which may have wrapped around the spindle.
- The main rotor and the chain table shafts are equipped with removable twine guards. The guards are mounted to the front and rear walls of the machine. The twine guards are bolted and need to be removed if you need to remove or tighten the bolts on the bearings or the hydraulic motors.
- Remove any twine which may have wrapped around the chain table shafts

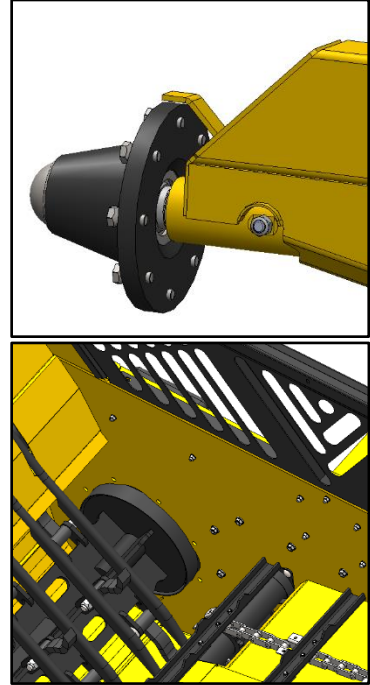



Rotor and Flail Replacement Procedure

Flail replacement is accomplished by removing the 3/4"x 4-3/4" bolt holding the flail to the rotor. The flail is then lifted away from the rotor. The bushing can now be removed by using slight pressure to push it out of the flail. Inspect the bolt, bushing, and the flail for wear. If wear is excessive, replace with new parts.

Bridgview Manufacturing Inc. recommends when changing flails to change in **PAIRS** (opposite each other). Processing bales with broken flails causes the rotor to be out of balance and excessive vibration may cause machine deterioration.

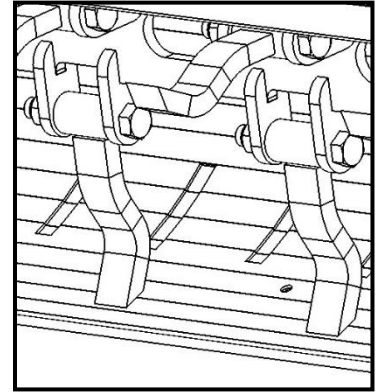

If a new rotor is required, care must be taken when reinstalling:

- Clean the spline and shaft ends of the rotor of any debris
- Clean the inside of the gearbox. Check the splines for damage.
- Remove the hoops
- Slide front twine guard over the rotor
- Drop rotor into top of tub. Drop the back side through the rear tub hole, then push the splined end through the front tub panel into the gearbox.
- Install new bearing to the rear bearing plate and torque to **200 ft-lb**. Slide bearing over the rotor shaft. Do not tighten collar yet.
- Check flail clearance of **1/2 to 5/8"** to tub panel
- Center the rotor in the tub so that the flails are centered between the hoops and slots
- Tighten bearing lock collar **counter-clockwise**. Apply *loc-tite* to the set screw and torque to **100 in-lb**.
- Check gearbox oil. Drain and replace if necessary.
- Add **100-150 pumps** of grease to the front gearbox grease zerk. Grease should begin coming out of the splines between the gearbox and tub
- Install front twine guard using 3/8" bolts. Make sure it is not rubbing on the rotor plate.



If a new gearbox is required, care must be taken when installing:

- Remove the 4 bolts holding the old gearbox to the tub. Drain oil and remove the drain plug from the gearbox
- Gently support the rotor to take the weight off of the gearbox
- Slide the gearbox off of the rotor shaft
- Clean and inspect the rotor splines for any damage. Replace if necessary
- Slide the new gearbox onto the rotor shaft. Lower the rotor so that it is held by the gearbox
- Bolt the gearbox to the tub using NEW bolts and washers provided. **Torque to 185 ft-lb**
- Install gearbox drain plug and breather. Install oil level sight glass as shown.
- Fill gearbox with oil. **1.7L of GL5 80W90**
- Apply grease to the front of the gearbox. About **150 pumps** will be required. Pump until grease starts to come out of the rotor spline between the gearbox and tub.

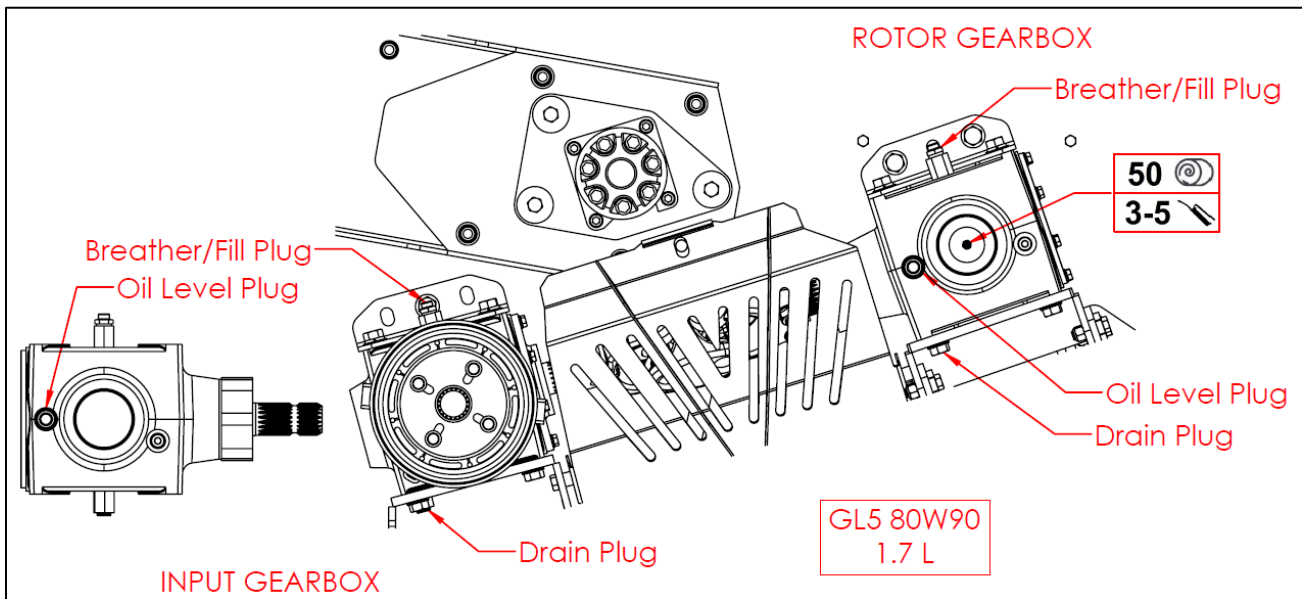



Trouble-shooting Guide

Problem	Possible Cause	Remedy
Excessive main shear bolt breakage	Engaging PTO at high engine speed or too quickly	<ul style="list-style-type: none"> • Idle tractor to engage PTO then bring up to full operating speed • Feather PTO lever into position
	Excessive twine wrapped on rotor causing flail movement to be restricted	<ul style="list-style-type: none"> • Cut twine off rotor
	Broken flails causing rotor to be out of balance	<ul style="list-style-type: none"> • Replace broken flails (in pairs opposite each other)
	Overloading rotor	<ul style="list-style-type: none"> • Set hoops to less aggressive position • Slow rotation of bale • Install 2 extra hoops for a total of 13 • Replace low profile hoops with high profile • Change direction of bale rotation
	Incorrect shear bolt used	<ul style="list-style-type: none"> • Use correct shear bolt (3/8 x 2" Gr.5 Fine Thread)
	Operating machine at less than 1000 PTO RPM	<ul style="list-style-type: none"> • Operate machine at rated 1000 PTO RPM
Excessive vibration while processing bales	Excessive twine wrapped on rotor causing flail movement to be restricted	<ul style="list-style-type: none"> • Cut twine off rotor
	Broken flails causing rotor to be out of balance	<ul style="list-style-type: none"> • Replace broken flails (in pairs opposite each other)
	Overloading rotor	<ul style="list-style-type: none"> • Set hoops to less aggressive position • Slow rotation of bale • Install 2 extra hoops for a total of 13 • Replace low profile hoops with high profile • Change direction of bale rotation
	Operating machine at less than 1000 PTO RPM	<ul style="list-style-type: none"> • Operate machine at rated 1000 PTO RPM
	Rotor bearing failure	<ul style="list-style-type: none"> • Replace failed parts
Bale not turning	Bale on fork or 3 bale clamp is contacting the bale in the tub	<ul style="list-style-type: none"> • Lower the forks • Adjust the bale in the 3 bale clamps by supporting with the fork bale, opening the clamps, lowering slightly, then re-clamping
	Excessive loose material in tub causing chain to lose contact with bale	<ul style="list-style-type: none"> • Reverse direction of bale rotation temporarily • Turn bale more slowly • Increase hoop aggression • Adjust top hoop setting
	Tractor relief pressure set too low	<ul style="list-style-type: none"> • Set tractor relief pressure to at least 2200 PSI
	Chain too tight	<ul style="list-style-type: none"> • Reduce chain tension
	Chain broken	<ul style="list-style-type: none"> • Replace failed parts
	Coupler between motor and drive shaft broken	<ul style="list-style-type: none"> • Replace failed parts
With 3 Bale Kit, fork is not lifting to full stroke	Bale or fork are hitting the 3 bale kit arms	<ul style="list-style-type: none"> • Lower fork and fully open 3 Bale Kit fully before lifting



FEATURES AND SPECIFICATIONS

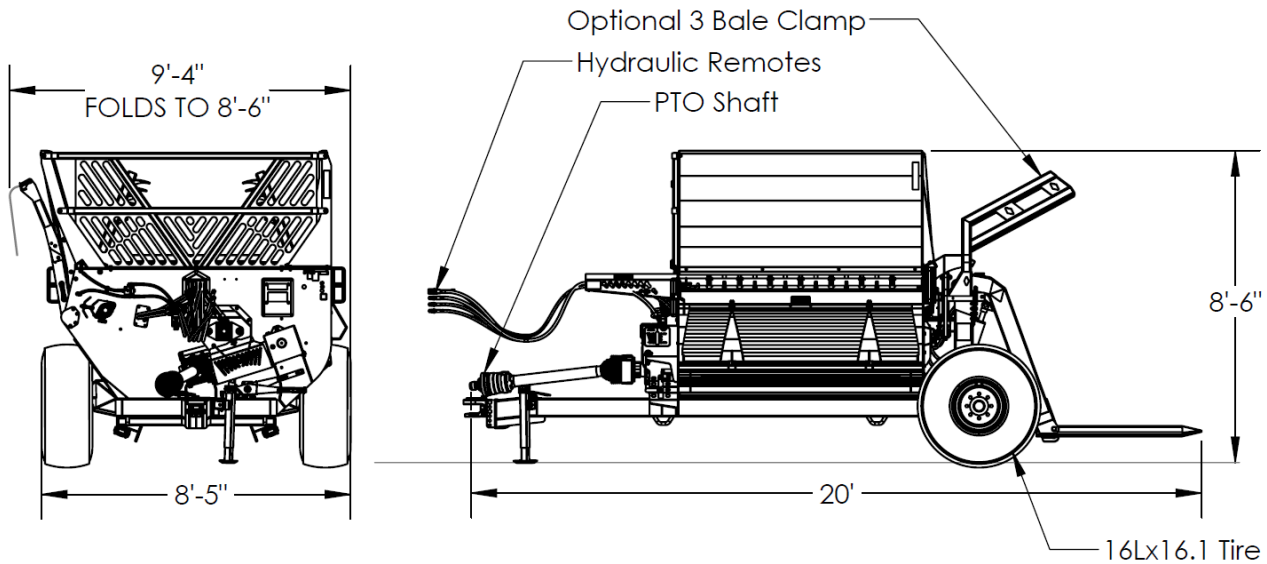

Dimensions:

	7400	7400X
Overall Weight	5700 lb	6100 lb
Drawbar Weight	1750 lb	1700 lb
Overall Length (Forks Up)	17'-2"	
Overall Width (Deflector Down)	11'-6"	
Tread Width (on centers)	7'-1"	
Rotor Extended Tip Diameter	27"	
Discharge Opening	80" wide, 9-12" high (adjustable)	

Wheels:

Tire Size	16L x 16.1 8 Ply
Tire Inflation	24 psi
Wheel Nut Torque	125 ft-lb

Driveline:

Minimum Horsepower	100 HP *Ensure sufficient horsepower for terrain driven.
PTO Shaft	Weasler Cat. 6 w/ 80 deg. C.V.
Shear Bolt	3/8 x 2" Fine Thread Gr. 5
Rated PTO RPM	1000 RPM
Rotor Flail Tip Speed at 1000 RPM	7000 FPM
Number of Rotor Flails	28
Rotor Flail Size	3/4 x 1-1/2 x 7"
Rotor Flail Bushing	Oil Impregnated Brass
Rotor Shaft	1-15/16" Bearing (rear)
Gearbox Oil	GL5 80W90
Gearbox Oil Capacity	1.7 L each



Hydraulics:

Required Remotes	7400	3 STD (2 OPTIONAL)
	7400X	4 STD (2 or 3 OPTIONAL)
Minimum Flow Requirements	15 GPM	
Minimum Pressure Requirements	1800 psi	

Other:

Chain Table Drive Shafts	1-3/4" Bearings (all)
Twine Guards	Rotor, Chain Table, Axles
Adjustable Bale Fork Width (on centers)	48 in. or 40.5 in.
Adjustable Hitch Height	4 settings at 1.5 in. intervals
Discharge deflector	Adjustable top and bottom
	Removable rubber end flap



PARTS MANUAL

Machine Overview	45
Jack and Hitch	46
Wheels & Hub	47
Hub & Spindle	48
Driveline	49
Driveline Guards	51
Rotor	54
Rotor Gearbox	56
Input Gearbox	57
Gearbox Coupler Shaft	58
PTO Shaft	59
Chain Table	60
Chain Table Overview	61
Chain & Slat Assembly	68
Chain & Slat Front Panel	62
Chain & Slat Rear Panel	64
Chain & Slat Access Panel	66
Hoop Grates	68
Hoop Grates	71
Adjustment Handles	72
Lower Tub Components	73
Lower Deflector	75
Fine Chop Option	76
Deflector	78
Upper Tub Components	80
Front Tub Components	84
Hose Holder & Hydraulic Clamps	87
Diverter Control Box	88
Rear Tub Components	90
Slow Moving Vehicle (SMV) Sign Kit	91
Lights	92
Rear Fork	94
Three Bale Kit Option	95
Three Bale Kit Left Arm	96
Three Bale Kit Right Arm	97
Three Bale Kit Center	98
Back-up Camera Option	99
Decals	100
HYDRAULIC SCHEMATICS	101



Machine Overview

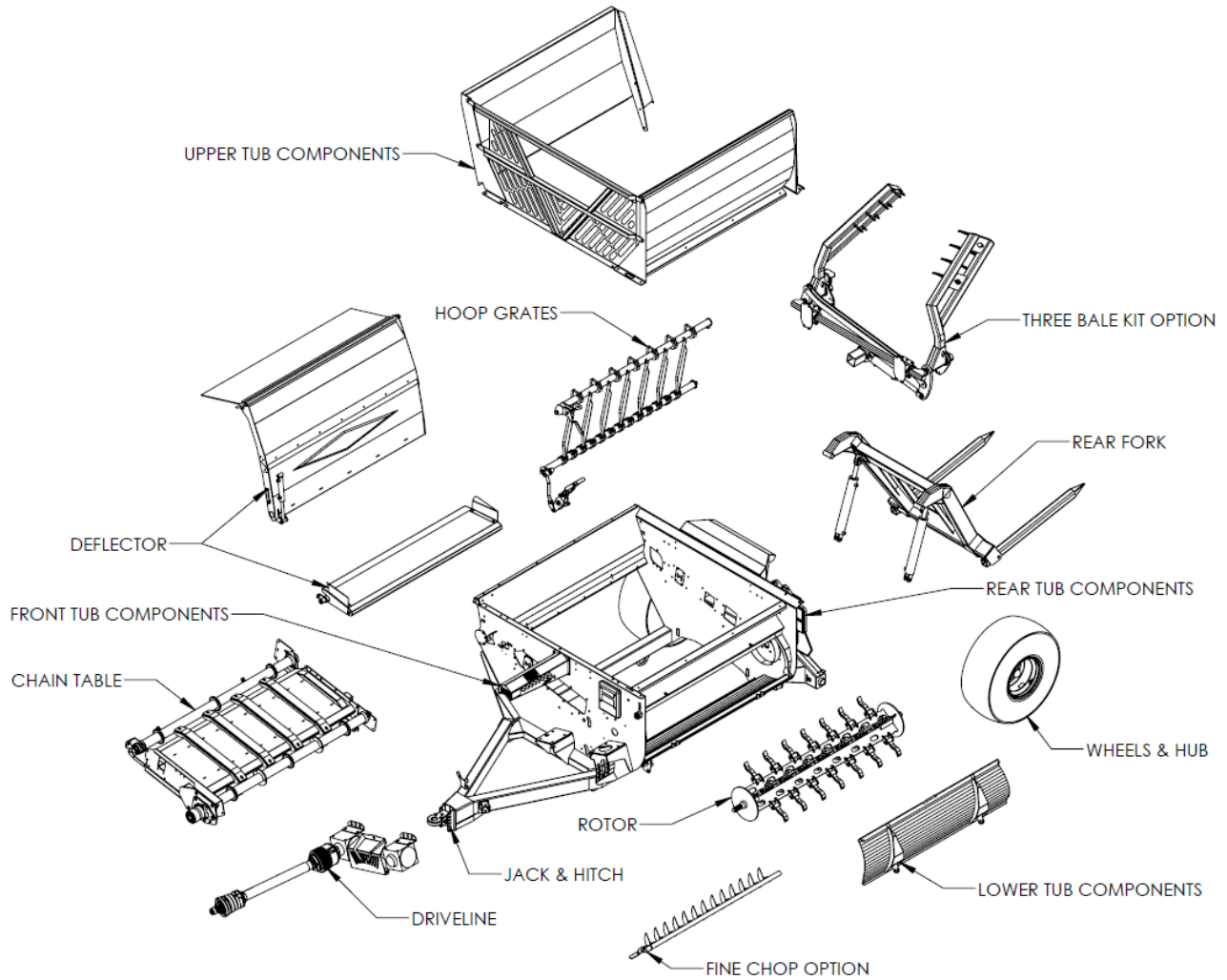

**

**** PAY ATTENTION TO SERIAL NUMBER RANGES WHERE APPLICABLE ****
THIS MANUAL IS FOR SERIAL NUMBERS BK7372 & UP ONLY.
FOR PRIOR SERIAL NUMBERS, CONTACT BRIDGEVIEW DIRECTLY.

Per quantities: A/R = As Required.
Per ID #: NSS = Not Sold Separately



Jack and Hitch

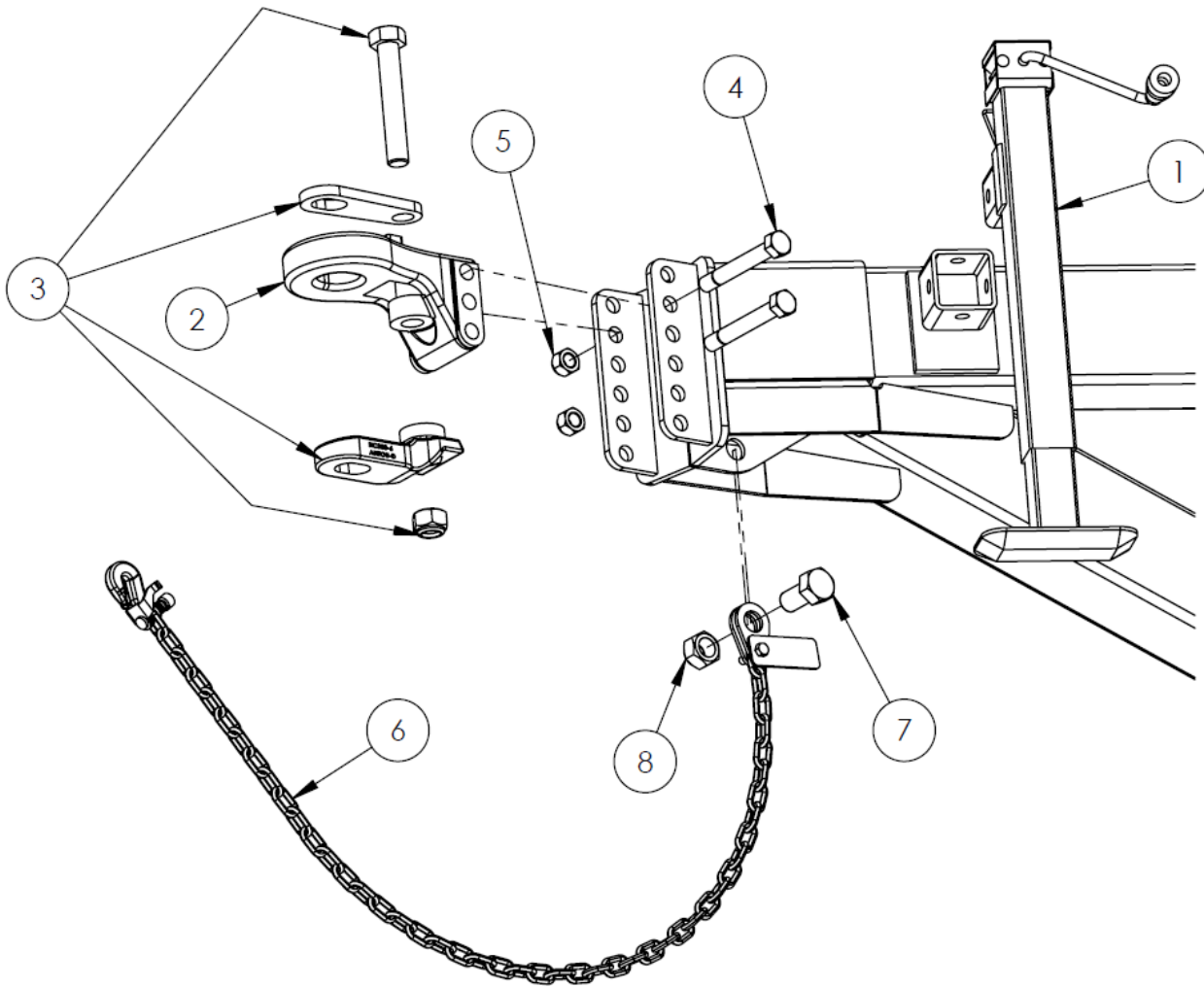

	Description	ID #	QTY		Description	ID #	QTY
1	Jack, 5000lb Square Mount w/ Pin	31637	1	5	Nut, 3/4" Stover Lock	11823	2
2	Hitch Tongue	29785	1	6	Safety Chain, 11000lb x 53"	21715	1
3	Hitch Clevis Kit <i>Individual parts NSS</i>	29786	1	7	Bolt, 1 x 2"	18992	1
4	Bolt, 3/4 x 5-5/8"	10802	2	8	Nut, 1" Stover Lock	21746	1



Wheels & Hub

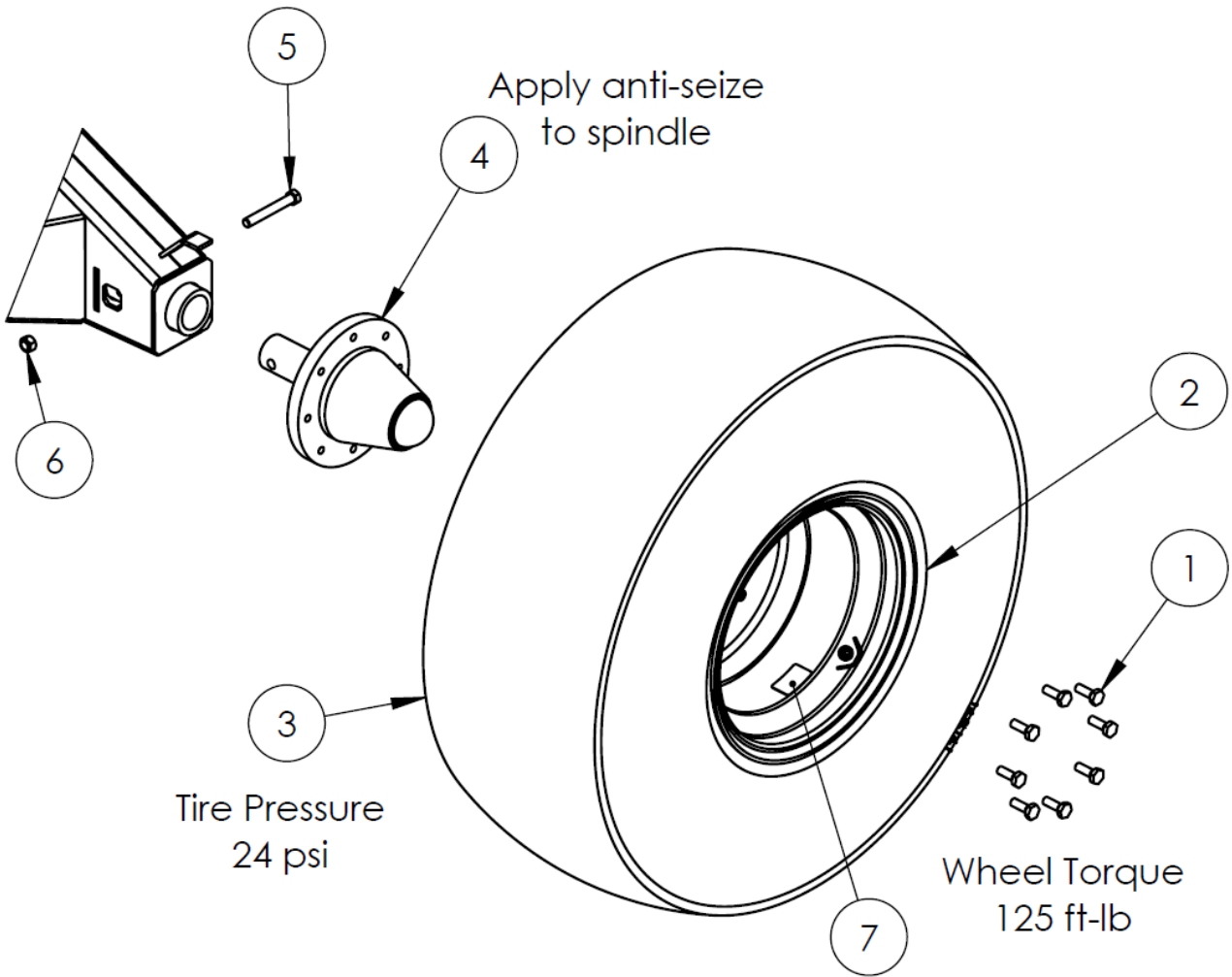

	Description	ID #	QTY		Description	ID #	QTY
1	Wheel Stud, 9/16" NF x 1-3/4"	10347	16	5	Bolt, 9/16 x 4"	33912	2
2	Rim, 16.1x14, 8 on 8"	10354	2	6	Nut, 9/16" Stover Lock	21165	2
3	Tire, 16.5L-16.1 8 ply	NSS	2	7	Wheel Torque Decal	28385	2
4	Spindle & Hub Assembly	29679	2				



Hub & Spindle

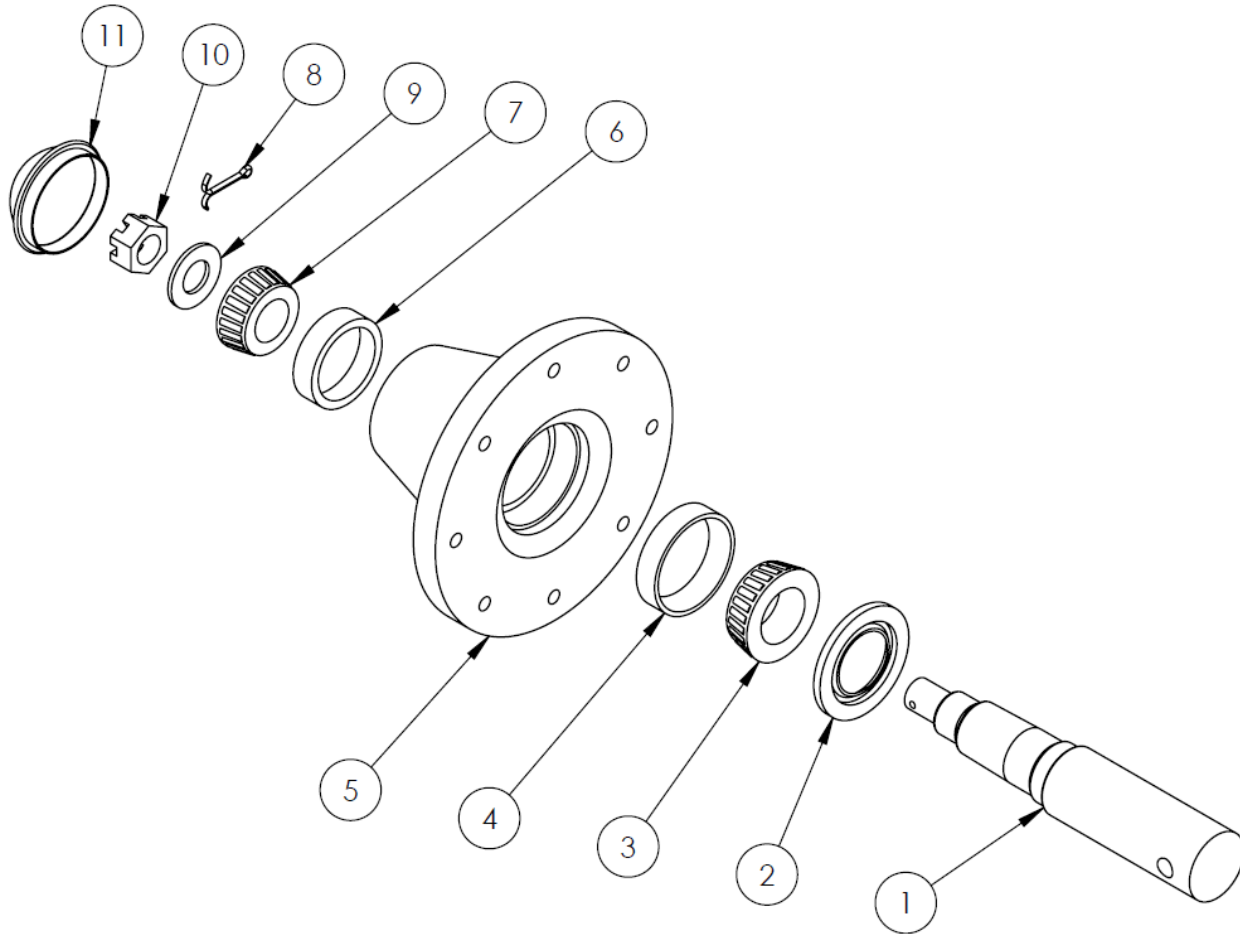

	Description	ID #	QTY		Description	ID #	QTY
-	Complete Assembly	29679	1	6	Outer Bearing Race 25821	10346	1
1	Bolt-on Spindle	29730	1	7	Bearing Cone, 1.375" LM25877	10348	1
2	Seal, 2" ID	10344	1	8	Cotter Pin, 3/16 x 1-1/2"	10072	1
3	Bearing Cone, 1.796" LM25590	10345	1	9	Flat Washer, 1-1/16" ID x 2" OD	10071	1
4	Inner Bearing Race 25520	10349	1	10	Castle Nut	10153	1
5	Hub Housing <i>Includes 4 & 6</i>	10343	1	11	Dust Cap	10350	1



Driveline

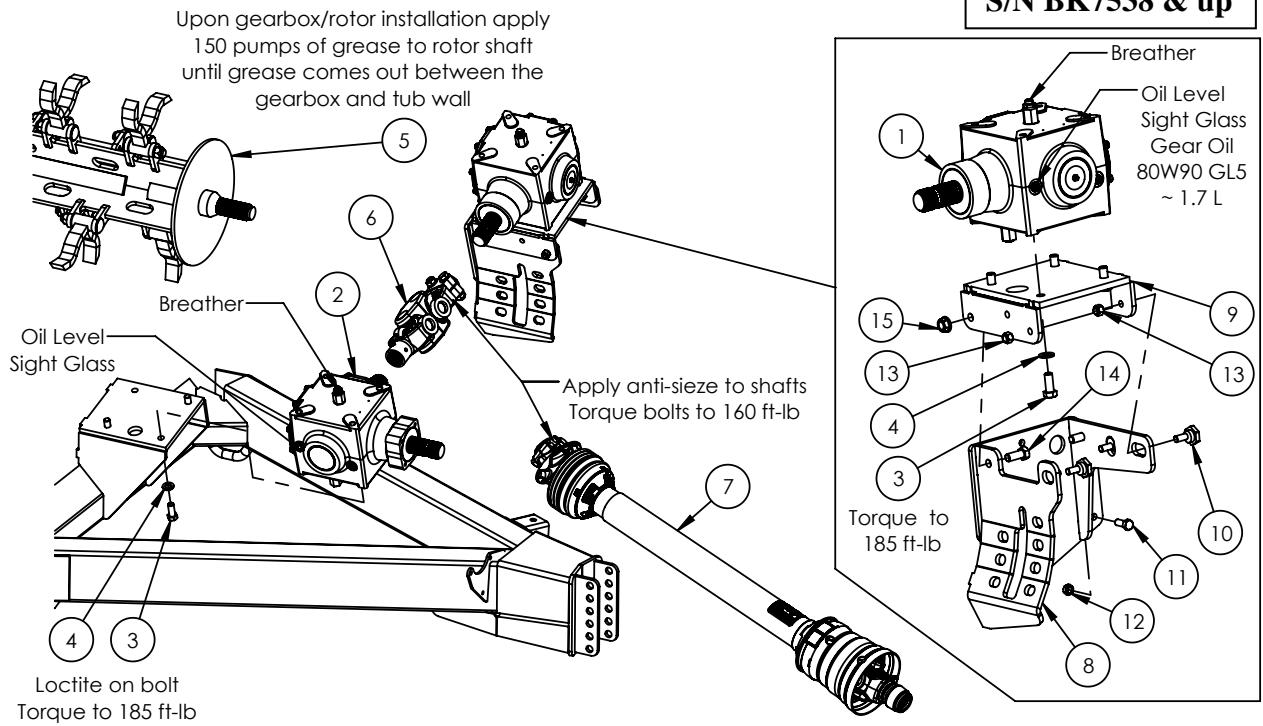

	Description	ID #	QTY		Description	ID #	QTY
1	Rotor Gearbox <i>Includes 3,4 mounting hardware See breakdown page 56</i>	35247	1	8	Gearbox Tub Mounting Plate @	35193	1
2	Input Gearbox <i>See breakdown page 57</i>	33010	1	9	Gearbox Adjustment Plate @	35191	1
3	Bolt, 5/8 x 1-1/2" w/ Threadlocker	33930	8	10	Cam Adjuster @	35203	3
4	Washer, 5/8" Nord-Lock	34441	8	11	Bolt, 1/2 x 1-1/4"	10240	8
5	Rotor <i>See breakdown page 54</i>	-	1	12	Nut, 1/2" Stover Lock	20154	8
6	Gearbox Coupler Shaft <i>See breakdown page 58</i>	32803	1	13	Nut, 1/2" NF Stover Lock	32153	3
7	PTO Shaft <i>See breakdown page 59</i>	20546	1	14	Bolt, 5/8 x 1-1/2"	33953	2
				15	Nut, 5/8" Stover Flange Lock	33842	2

@ When installing a new gearbox mounting plate, an alignment kit is required.

This kit #34468 can be rented from Bridgeview. This will ensure that the gearbox is properly aligned
Always install new bolts (3) if gearboxes are removed.



Driveline

S/N BK7408 - 7537

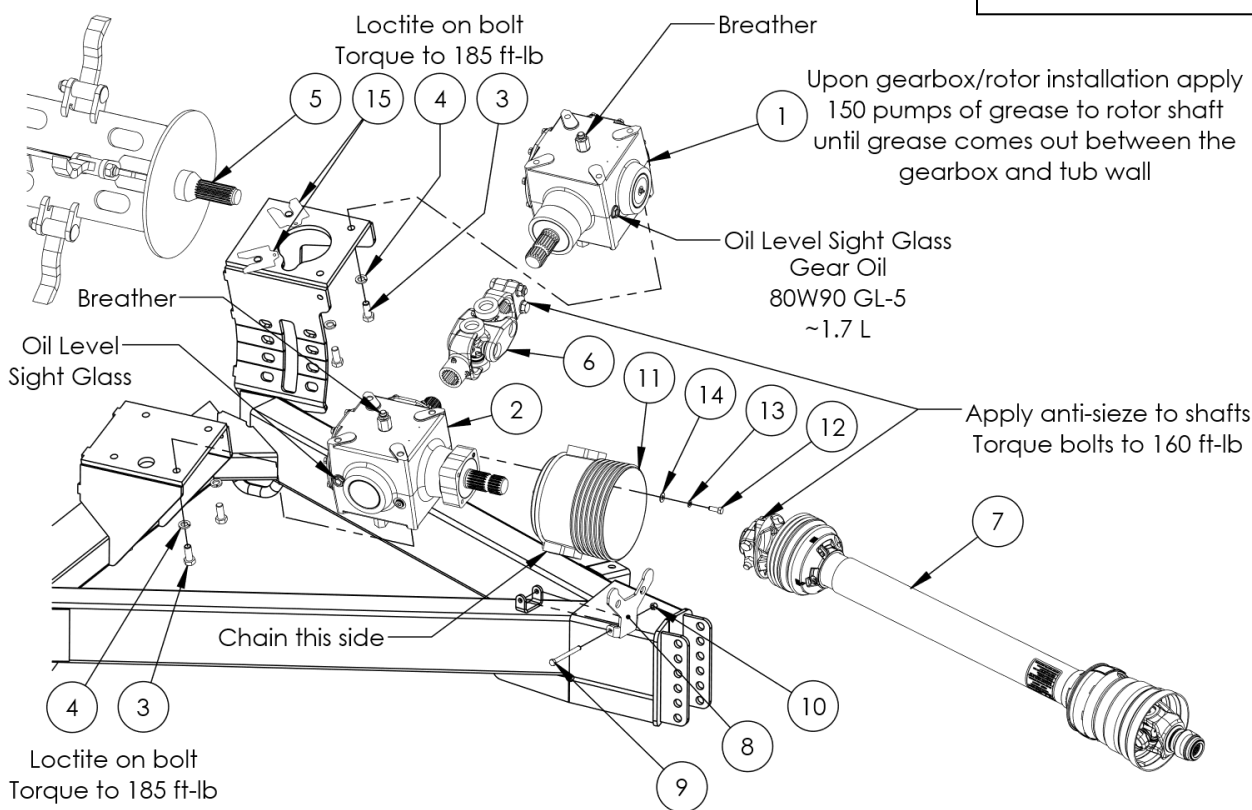

	Description	ID #	QTY		Description	ID #	QTY
1	Rotor Gearbox @ Includes 3,4 mounting hardware See breakdown page 56	35247	1	9	Bolt, 3/8 x 4"	14379	1
2	Input Gearbox See breakdown page 57	33010	1	10	Nut, 3/8" Nylon Lock	10806	1
3	Bolt, 5/8 x 1-1/2" w/ Threadlocker	33930	8	11	PTO Guard	34899	1
4	Washer, 5/8" Nord-Lock	34441	8	12	Bolt, 3/8 x 1"	13806	4
5	Rotor See breakdown page 54	-	1	13	Washer, 3/8" Lock	13971	4
6	Gearbox Coupler Shaft See breakdown page 58	32803	1	14	Washer, 3/8" Flat	11667	4
7	PTO Shaft See breakdown page 59	20546	1	15	Gearbox Shims		A/R
8	PTO Cradle	31760	1		.050" Thick	34335	
					.025" Thick	34336	
					.015" Thick	34337	
					.010" Thick	34338	
				.005" Thick	34339		
				.003" Thick	34340		

**@ When installing a new rotor gearbox, an alignment kit is required.
This kit #34468 can be rented from Bridgeview. This will ensure that the proper shims are used.
Always install new bolts (3) if gearboxes are removed.**



Driveline Guards

S/N BK7538 & up

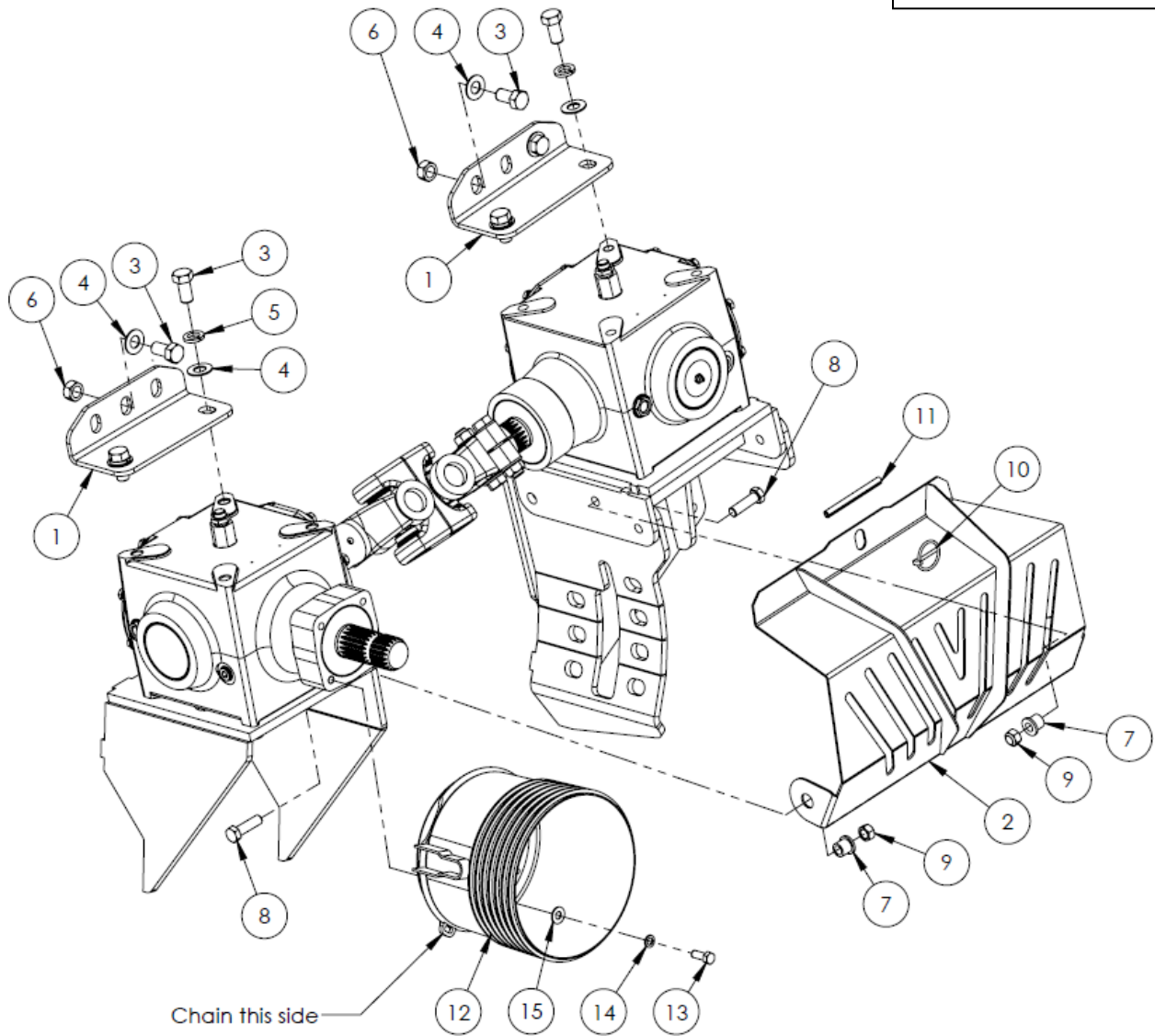

	Description	ID #	QTY		Description	ID #	QTY
1	Gearbox Upper Cover Bracket	34311	2	9	Nut, 1/2" Stover Lock	20154	2
2	Gearbox Coupler Guard	35201	1	10	Lynch Pin	13233	1
3	Bolt, 5/8 x 1-1/4"	24645	7	11	Rubber Trim	35205	1
4	Washer, 5/8" Flat	13975	7	12	PTO Guard	34899	1
5	Washer, 5/8" Lock	10276	4	13	Bolt, 3/8 x 1"	13806	4
6	Nut, 5/8" Stover Lock	20150	3	14	Washer, 3/8" Lock	13971	4
7	Flanged Bushing	33002	2	15	Washer, 3/8" Flat	11667	4
8	Bolt, 1/2 x 1-3/4"	10805	2				



Driveline Guards

S/N BK7428 - 7537

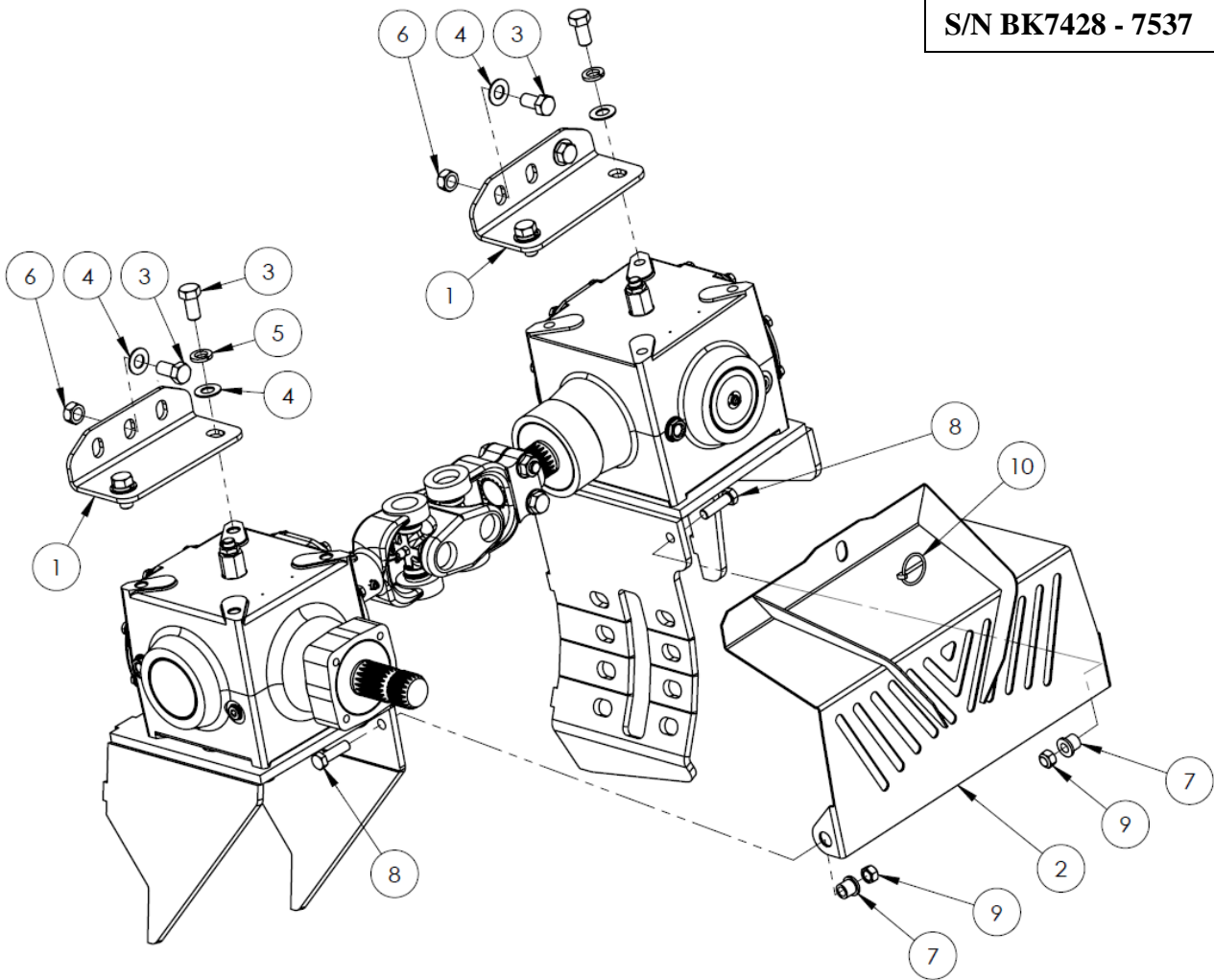

	Description	ID #	QTY		Description	ID #	QTY
1	Gearbox Upper Cover Bracket	34311	2	6	Nut, 5/8" Stover Lock	20150	3
2	Gearbox Coupler Guard	33718	1	7	Flanged Bushing	33002	2
3	Bolt, 5/8 x 1-1/4"	24645	7	8	Bolt, 1/2 x 1-3/4"	10805	2
4	Washer, 5/8" Flat	13975	7	9	Nut, 1/2" Stover Lock	20154	2
5	Washer, 5/8" Lock	10276	4	10	Lynch Pin	13233	1



Driveline Guards

S/N BK7408 - 7427

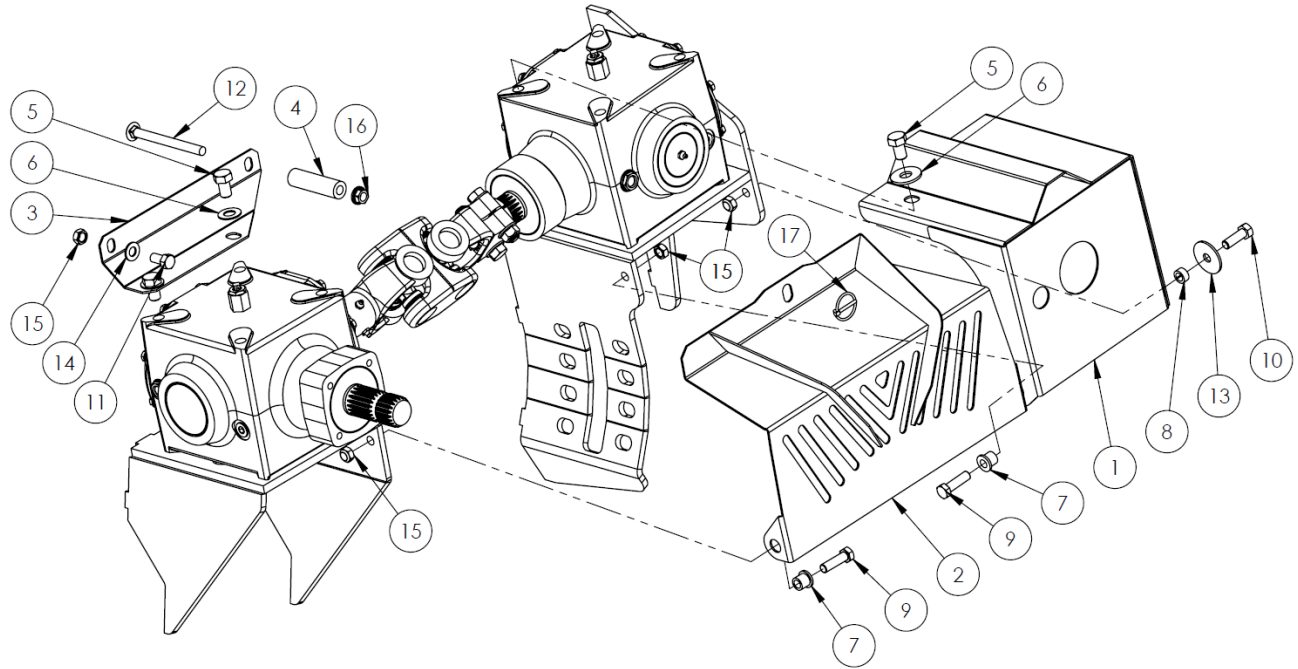

	Description	ID #	QTY		Description	ID #	QTY
1	Gearbox Guard	33753	1	10	Bolt, 1/2 x 1-1/2"	10174	1
2	Gearbox Coupler Guard	33718	1	11	Bolt, 1/2 x 1"	10824	1
3	Input Gearbox Cover	33726	1	12	Bolt, 1/2 x 5-1/2"	32983	1
4	Chain Motor Mount Spacer Pipe	33719	1	13	Washer, 1/2" Fender	10238	1
5	Bolt, 5/8 x 1"	15576	3	14	Washer, 1/2" Flat	11668	1
6	Washer, 5/8" Flat	13975	3	15	Nut, 1/2" Stover Lock	20154	4
7	Flanged Bushing	33002	2	16	Nut, 1/2" Serrated Flange	10273	1
8	Spacer Bushing	27528	1	17	Lynch Pin	13233	1
9	Bolt, 1/2 x 1-3/4"	10805	2				



Rotor

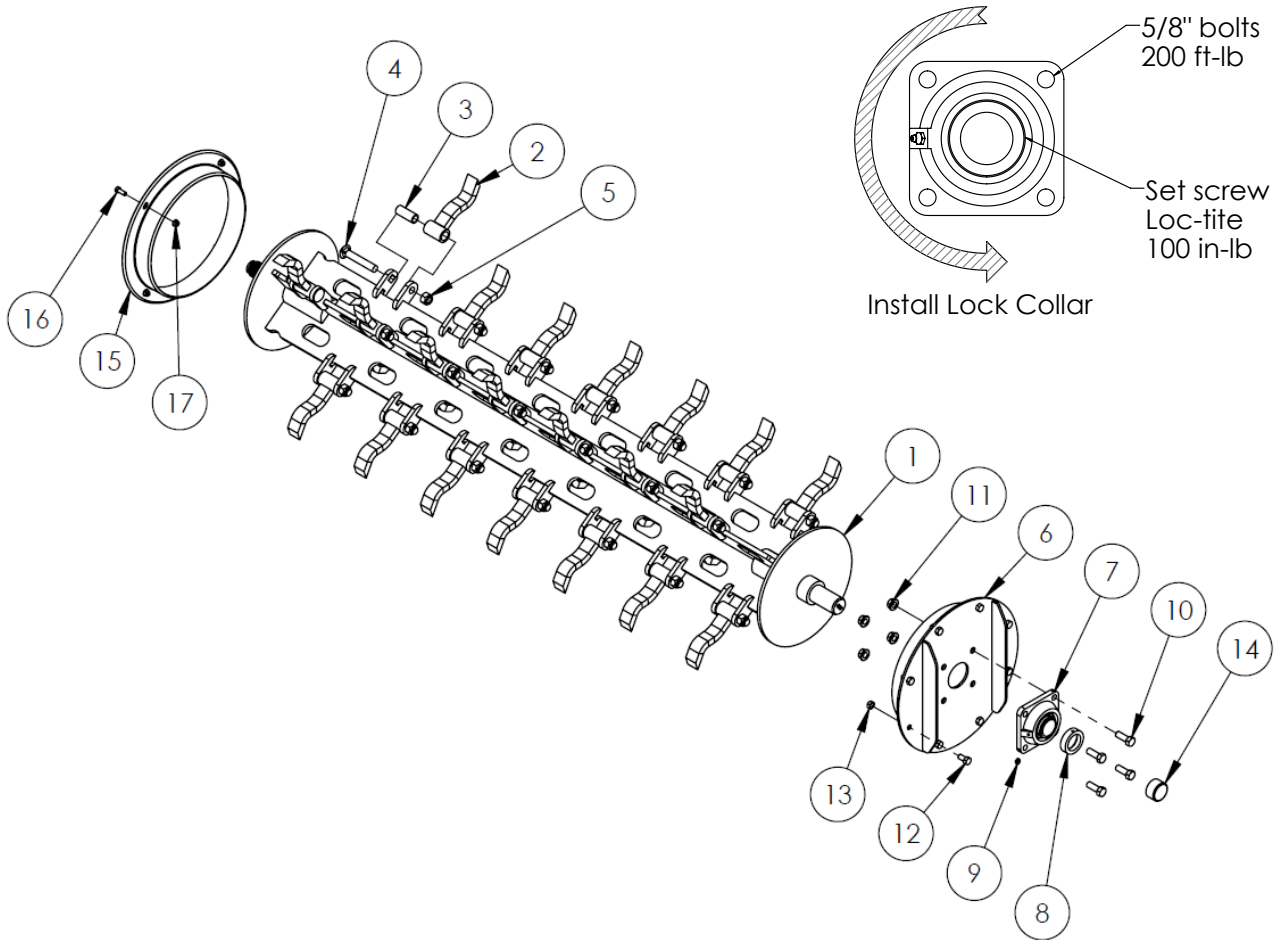

	Description	ID #	QTY		Description	ID #	QTY
1	X-Rotor Weldment	33758	1	9	Grease Zerk, 1/8" NPT	10270	
2	Rotor Flail <i>Always replace in pairs</i>	22412	28	10	Bolt, 5/8"-18 x 1-3/4"	10274	4
3	Rotor Flail Bushing	10005	28	11	Nut, 5/8"-18 Stover Flange	15398	4
4	Flail Bolt, 3/4 x 4-1/2" Carriage	32279	28	12	Bolt, 1/2 x 1"	10824	8
5	Nut, 3/4" Stover Lock	11823	28	13	Nut, 1/2" Stover Lock	20154	8
6	Rotor Bearing Plate	33718	1	14	Rotor Shaft Cap	17380	1
7	Complete Bearing Assembly <i>Includes 8,9</i>	10221	1	15	Rotor Twine Guard	22413	1
8	Bearing Lock Collar	NSS	1	16	Bolt, 3/8 x 1"	13806	4
				17	Nut, 3/8" Serrated Flange	10271	4





An end plate upgrade kit is available for any leak in and around end plate #2
KIT # 35283

Rotor Gearbox

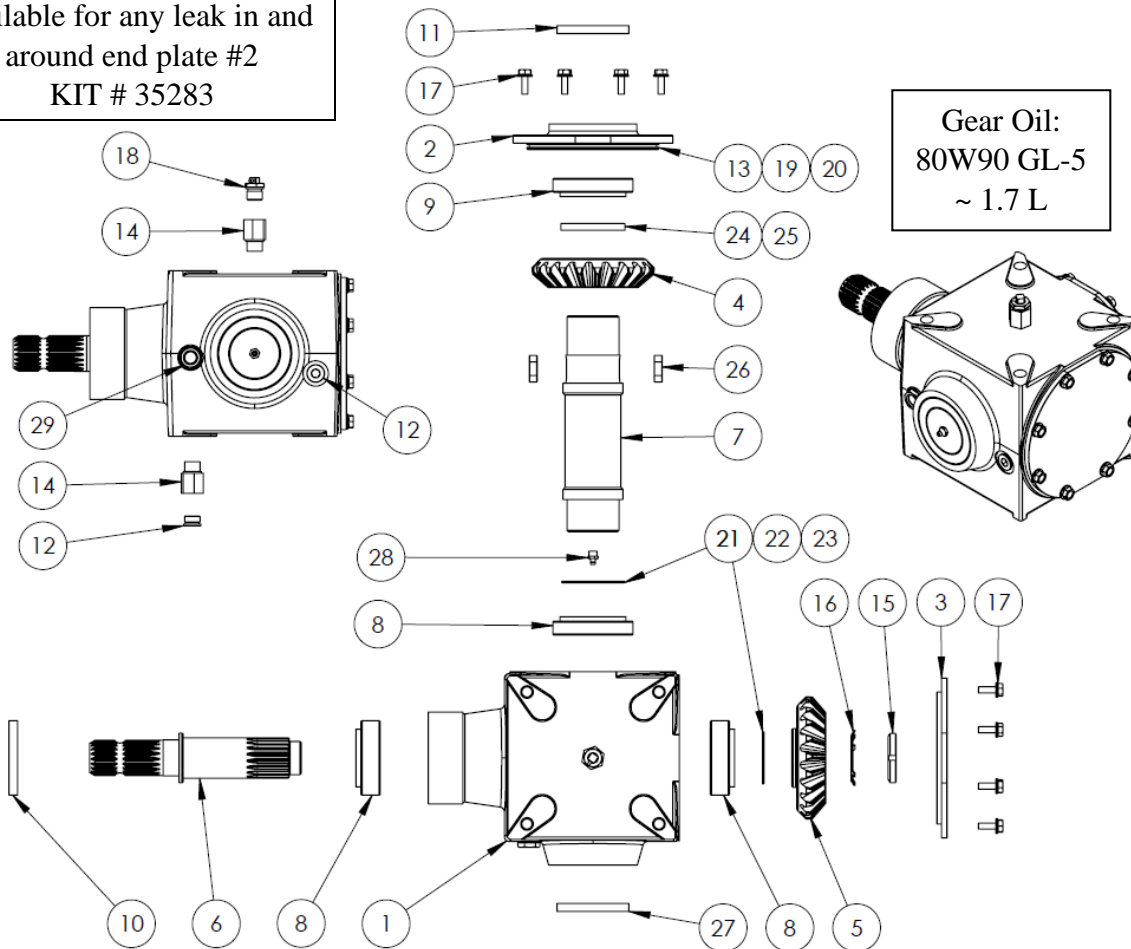

	Description	ID #	QTY		Description	ID #	QTY
-	Rotor Gearbox	35247	1	15	Locknut (M42x1.5)	34887	1
1	Housing	-	1	16	Retainer	34889	1
2	End Cap	*35283	1	17	3/8 x 1" Flange Bolt		16
3	Cover Plate	-	1	18	Relief Plug (1/2"-14 NPT)	34833	1
4	Gear	-	1	19	Gasket	*35283	A/R
5	Gear	-	1	20	Gasket	*35283	A/R
6	Shaft	-	1	21	Shim (51x65x1.6)	34890	2
7	Shaft	-	1	22	Shim (51x61x0.1)	34891	A/R
8	Bearing (3780/3720)	34885	3	23	Shim (51x61x0.2)	34892	A/R
9	Bearing (32013)	34886	1	24	Shim (65.2x80x6.5)	34893	1
10	Seal (45x93.26x11)	34244	1	25	Shim (65.2x78x0.1)	*35283	A/R
11	Seal (65x90x10)	34882	1	26	Key		2
12	Plug (1/2"-14 NPT)	14192	2	27	Seal (50.8x81.13x11)	34844	1
13	O-Ring (153.8x3.1)	*	1	28	Grease Zerk, M10	10592	1
14	Bushing (1/2"-14 NPT)	34246	2	29	Oil Level Sight Glass	33672	1



Input Gearbox

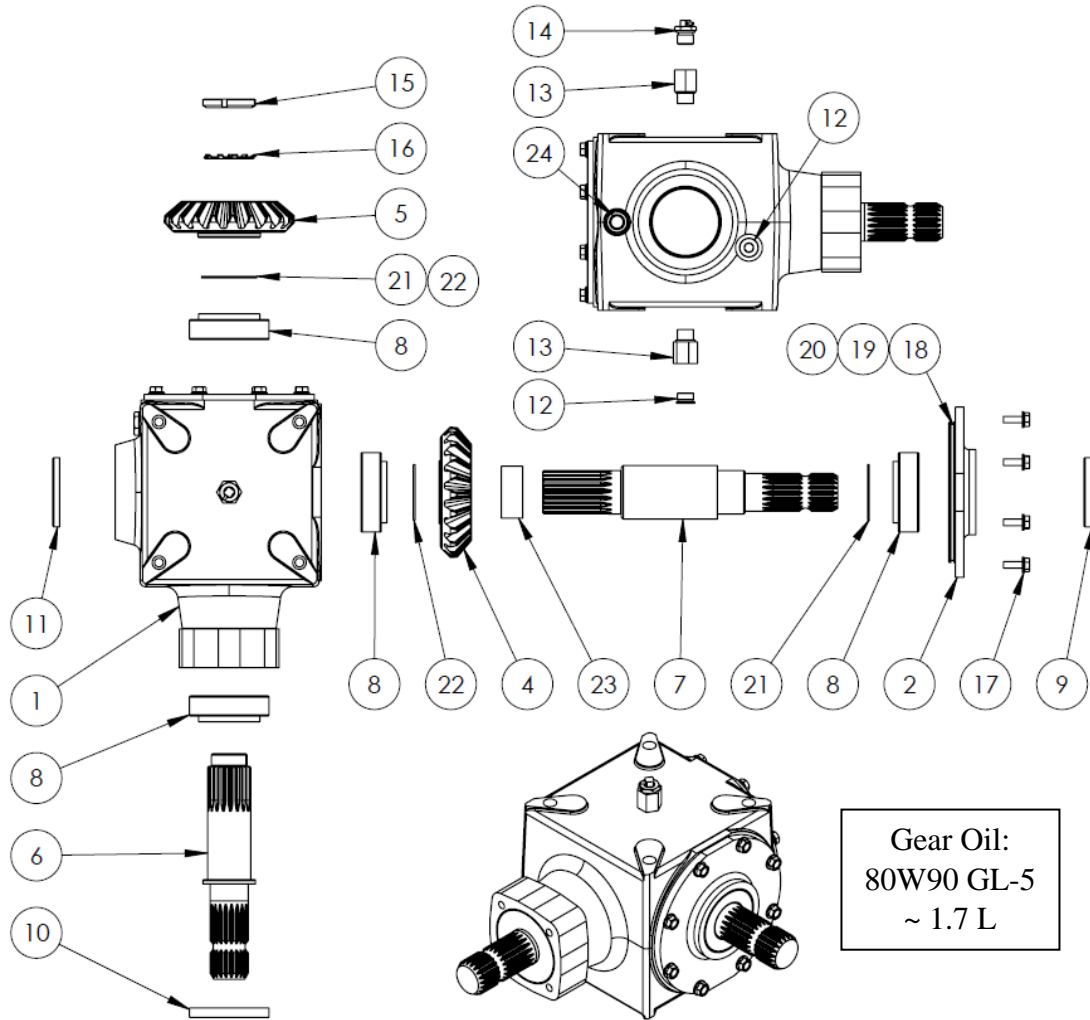

	Description	ID #	QTY		Description	ID #	QTY
-	Input Gearbox	33010	1	13	Bushing (1/2"-14 NPT)	34246	2
1	Housing	-	1	14	Relief Plug (1/2"-14 NPT)	34833	1
2	End Cap	-	1	15	Locknut (M42x1.5)	34887	1
3	Cover Plate	-	1	16	Retainer	34889	1
4	Gear	-	1	17	3/8 x 1" Flange Bolt		16
5	Gear	-	1	18	O-Ring (153.8x3.1)	34895	1
6	Shaft	-	1	19	Gasket	34247	A/R
7	Shaft	-	1	20	Gasket	34888	A/R
8	Bearing (3780/3720)	34885	4	21	Shim (51x65x1.6)	34890	2
9	Seal (44.45x81.13x8)	34243	1	22	Shim (51x61x0.1)	34891	A/R
10	Seal (45x93.26x11)	34244	1	23	Bushing (51x60x25)	-	1
11	Seal (81.13x11)	34245	1	24	Oil Level Sight Glass	33672	1
12	Plug (1/2"-14 NPT)	14192	2				



Gearbox Coupler Shaft

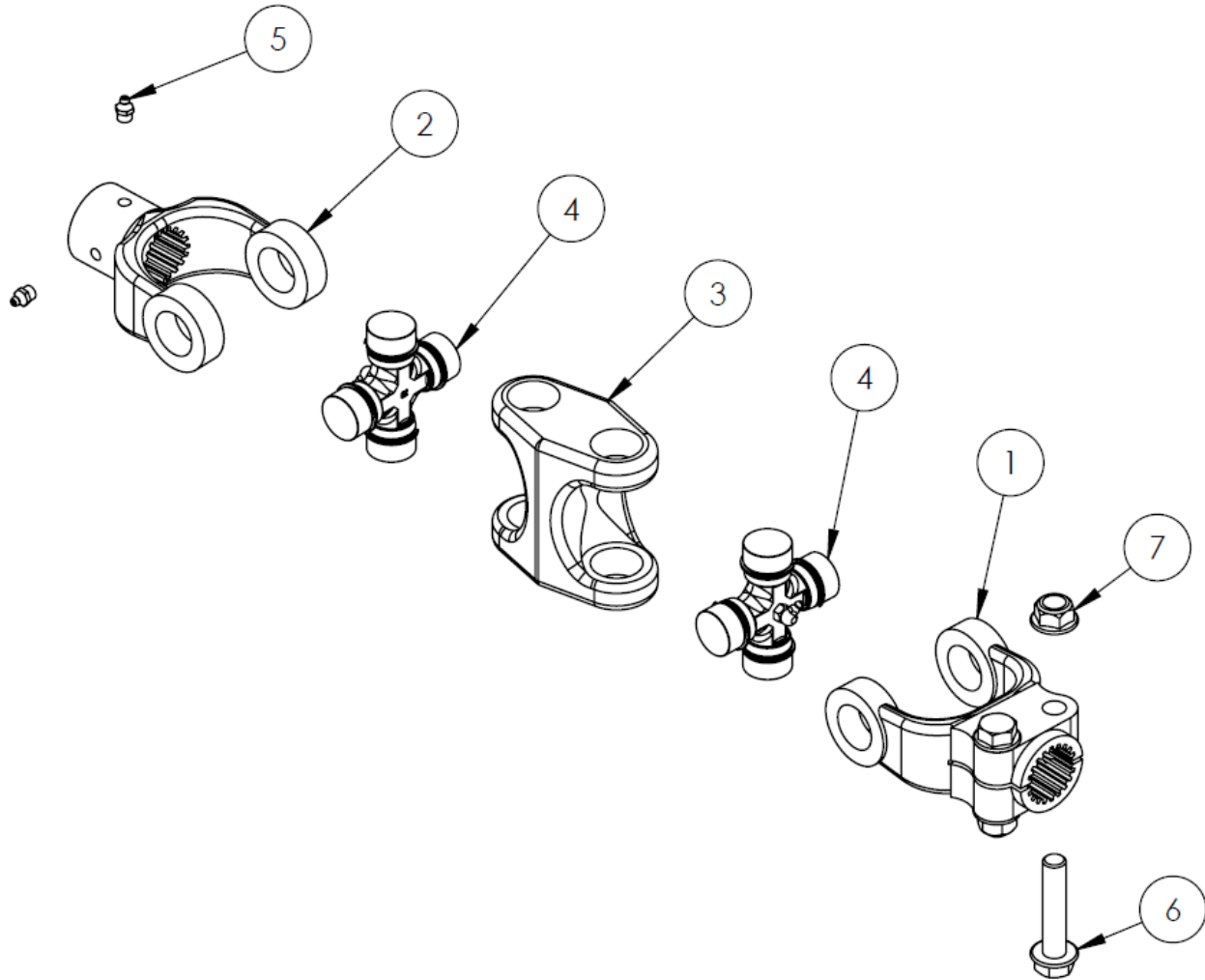

	Description	ID #	QTY		Description	ID #	QTY
-	Gearbox Coupler Shaft	32803	1	4	Cross & Bearing Kit	33840	2
1	Clamp-on Yoke	NSS	1	5	Grease Zerk, 1/8" NPT	10270	4
2	Greaseable Yoke	NSS	1	6	Bolt, 5/8 x 3" Flange Head	33841	2
3	Double Center Yoke	NSS	1	7	Nut, 5/8" Stover Flange	33842	2



PTO Shaft

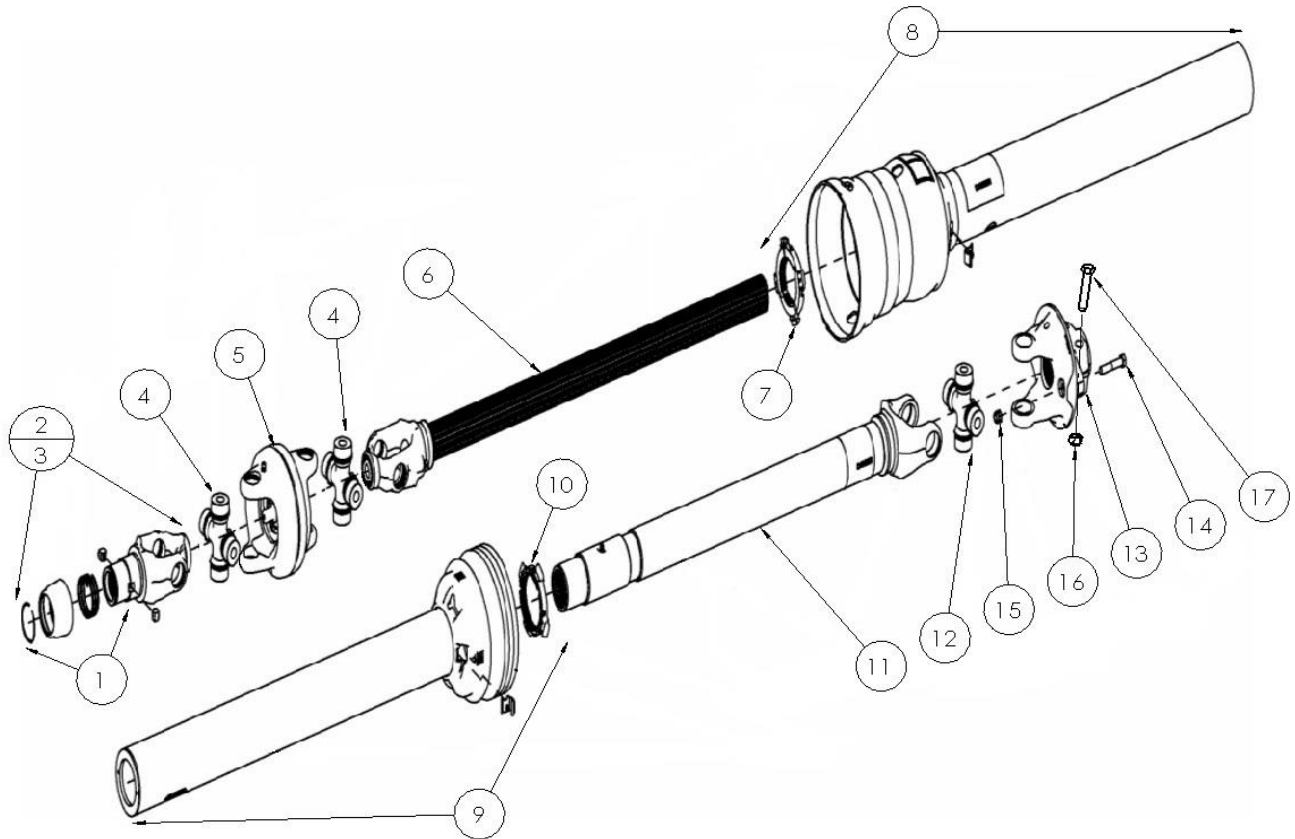

	Description	ID #	QTY		Description	ID #	QTY
-	Complete PTO Shaft Assembly (1-3/8"-21 Spline)	20546	1	8	Guard Assembly Tractor Side	17583	1
1a	Safety Lock Repair Kit (1-3/8"-21 Spline)	17567	1	9	Guard Assembly Implement Side	17585	1
1b	Safety Lock Repair Kit (1-3/4"-20 Spline)	24981		10	Guard Repair Kit Implement Side	17572	1
2	WWCV Auto-Lock Yoke Assy. (1-3/8"-21 Spline)	20549	1	11	Yoke & Tube Assy Implement Side	17584	1
3	WWCV Auto-Lock Yoke Assy. (1-3/4"-20 Spline)	20556		12	U-joint Cross & Bearing Kit	17573	1
4	CV Cross & Bearing Kit	20550	2	13	Shear Assembly <i>Does not come parts 14 - 17</i>	29963	1
5	CV Center Housing	20551	1	14	Shear Bolt, 3/8" x 2" Fine Thread	33285	1
6	Yoke & Shaft Assembly Tractor Side	20552	1	15	Nut, 3/8" Fine Thread Stover Lock	33286	1
7	Guard Repair Kit Tractor Side	20553	1	16	Nut, 5/8" Stover Lock	24982	2
				17	Bolt, 5/8" x 3-1/2"	24983	2

NOTE: Ensure that the PTO shaft on the machine is correct to the drawings below. Equal length CV cross (4.19") with bearing cup diameter 1.38". If the damaged PTO has different dimensions, consult the Bridgeview Manufacturing website.

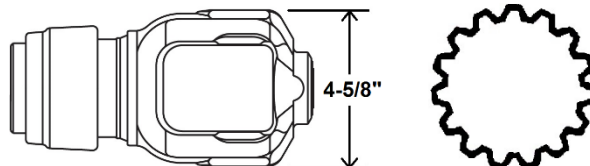



Chain Table

	Description	ID #	QTY		Description	ID #	QTY	
1	Chain Sprocket Drive Shaft	33745	1	31	Washer, 3/8" Flat	11667	2	
2	Chain Sprocket Idler Shaft	33742	1	32	Nut, 3/8" Nylon Lock	10806	6	
3	Drive Shaft Rear Support Plate	33760	1	33	Lynch Pin, 5/16 x 2" Lock Pin, 1/4 x 1-3/4"	23077 13669	2	
4	Idler Shaft Rear Support Plate	33711	1	34	Chain Drive Motor Seal Kit Apply anti-seize to shaft	28702 25891	1	
5	Idler Shaft Adjuster	33710	2		35	Grommet, 1" ID x 3/32"	33000	3
6	Motor Mount S/N BK7408 - 7427 only	33709	1	36	Chain Slat Plastic S/N BK7428 & up S/N BK7415 - 7427 S/N BK7408 - 7414	338752 338751 33875	4	
7	Motor Mount Spacer S/N BK7408 - 7427 only	33719	1		37	Chain & Slat Assembly See breakdown page 68	33832	1
8	Twine Guard	33743	4		38	Chain Slat	33755	8
9	Motor Adaptor Plate S/N BK7428 & up S/N BK7408 - 7427	34304 33694	1	39	Chain with Attachments Includes 40	32936	3	
10	Chain Shaft Bearing Comes with 11 & 12	32969	4	40	Chain Connector Link	23093	3	
11	Bearing Lock Collar	10040	4	41	Chain Half Link	33900	A/R	
12	Bearing Grease Zerk	33901	4	42	Bolt, 5/16 x 3/4"	20903	48	
13	Bolt, 5/8 x 4" Carriage	33007	2	43	Nut, 5/16" Nylon Lock	11815	48	
14	Bolt, 5/8 x 2-1/4" Carriage	20229	8	44	Chain Access Panel Includes 52,55	33703	1	
15	Washer, 5/8" Flat	13975	8	45	Chain Table Cleanout Door	33712	1	
16	Nut, 5/8" Nylon Lock	10364	8	46	Chain Access Panel Support Rail	33720	2	
17	Nut, 5/8" Serrated Flange	11614	2	47	Chain Adjustment Indicator	33510	2	
18	Nut, 5/8" Smooth Flange	33009	4	48	Pop Rivet, 1/8" Backing Washer	35148 35149	4 4	
19	Bolt, 1/2 x 5-1/2" Carriage	32983	-	49	Hydraulic Fitting, 10MB-8MJ45	23844	2	
20	Bolt, 1/2 x 2-1/2"	10804	3	50	Chain Table Frame S/N BK7428 & up	34329	1	
21	Bolt, 1/2 x 2-1/4"	11820	-	51	Bolt, 1/2 x 2-1/2" Socket Head	16863	4	
22	Bolt, 1/2 x 1-1/2" Button Head	33303	8	52	Chain Access Panel Wear Strip	34278	2	
23	Bolt, 1/2 x 1-1/4" Carriage	11819	32	53	Cleanout Door Hinge Bushing	34292	2	
24	Bolt, 1/2 x 1"	10824	-	54	Pop Rivet, 3/16 x 3/8"	20963	12	
25	Washer, 1/2" Fender	10238	11	55	Bolt, 1/2 x 1-1/2"	10174	1	
26	Nut, 1/2" Stover Lock	20154	15	56	Washer, 1/2" Flat	11668	1	
27	Nut, 1/2" Serrated Flange	10273	32	57	Pop Rivet, 3/16 x 1/2"	21227	4	
28	Bushing, 1/2" ID x 9/16"	33590	8					
29	Bolt, 3/8 x 1"	13806	2					
30	Bolt, 3/8 x 1" Carriage	15718	4					



Chain Table Overview

See reference table page 60

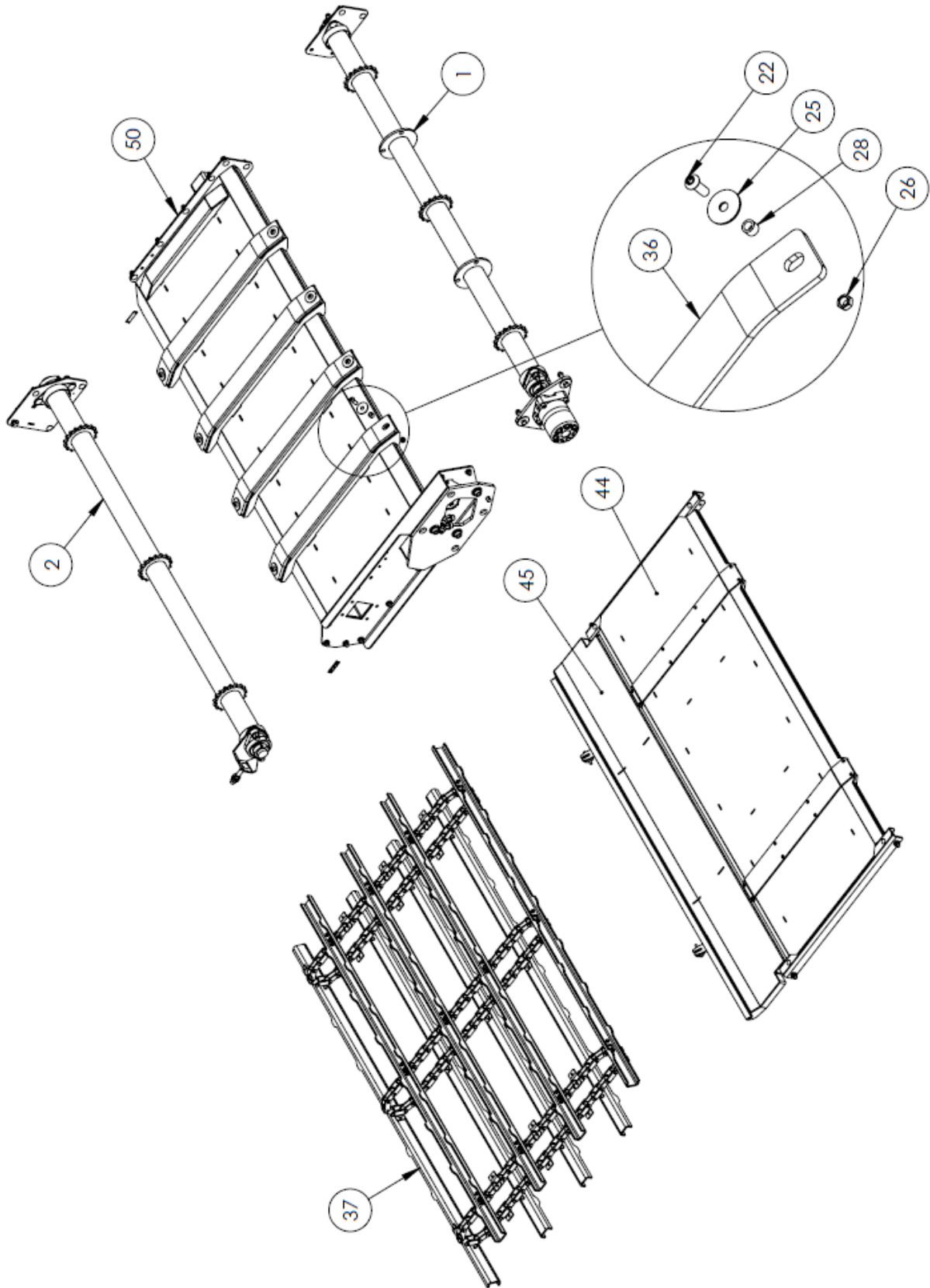



Chain & Slat Front Panel

See reference table page 60

S/N BK7428 & up

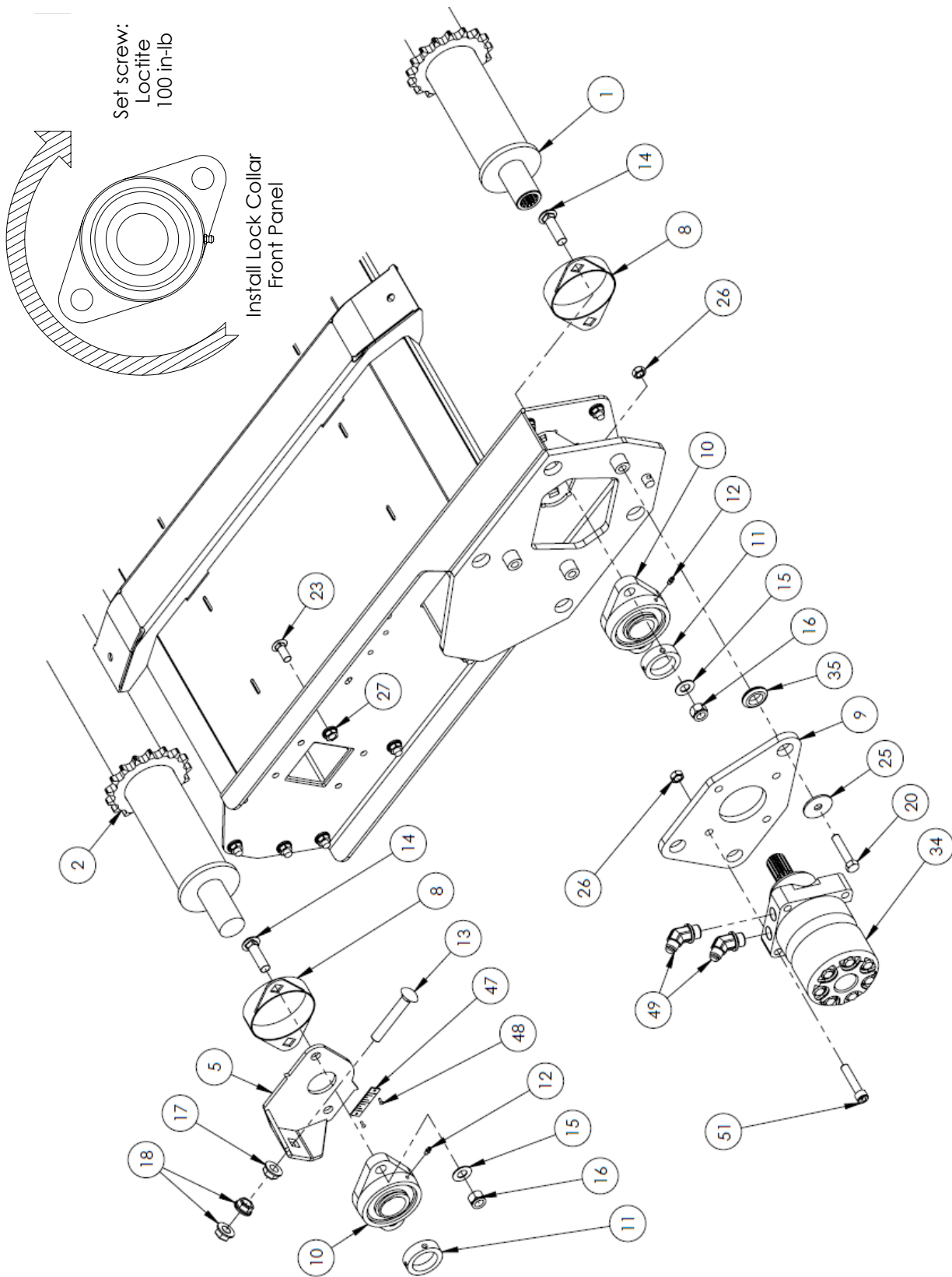



Chain & Slat Front Panel

See reference table page 60

S/N BK7408 - 7427

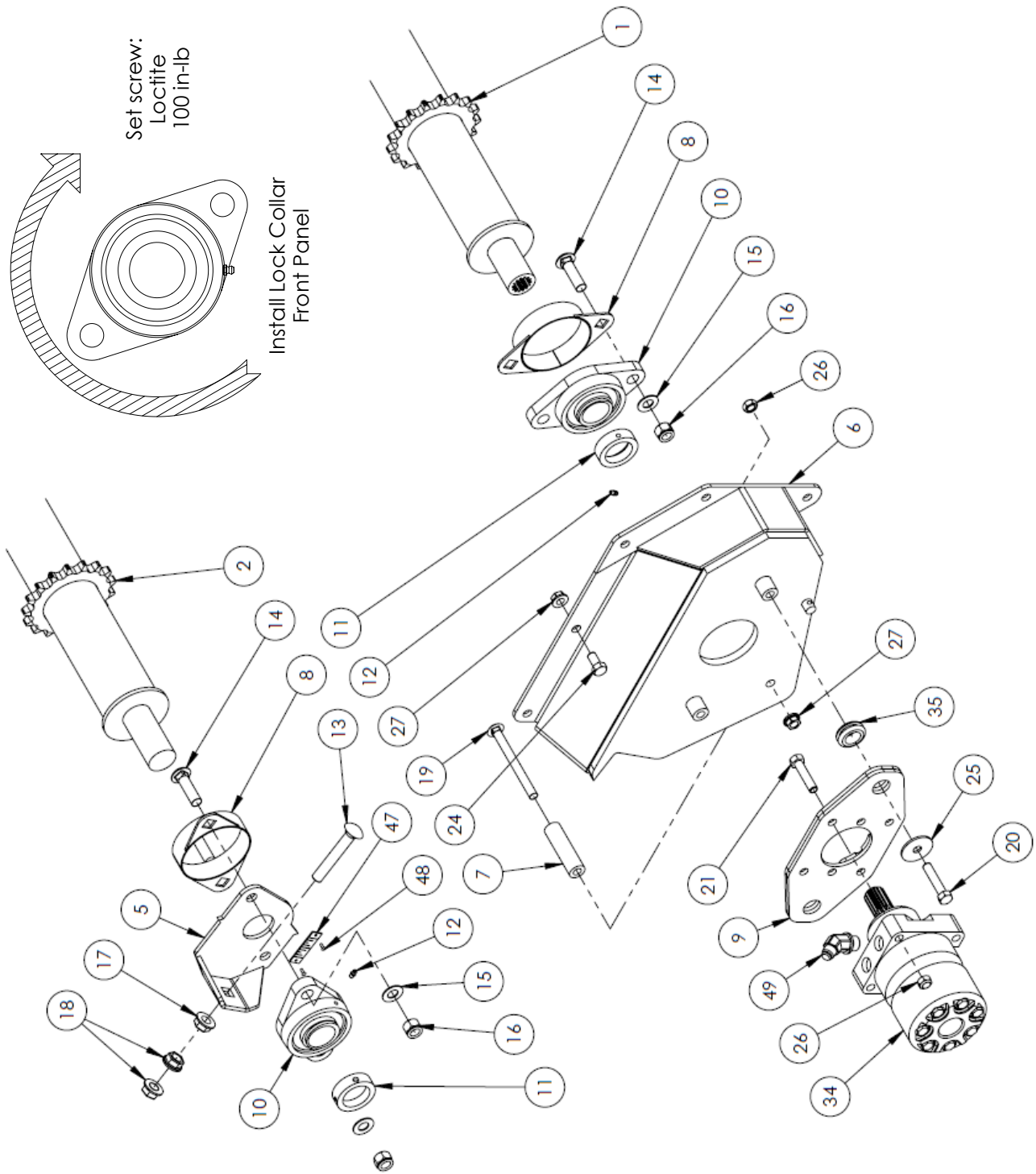



Chain & Slat Rear Panel

See reference table page 60

S/N BK7428 & up

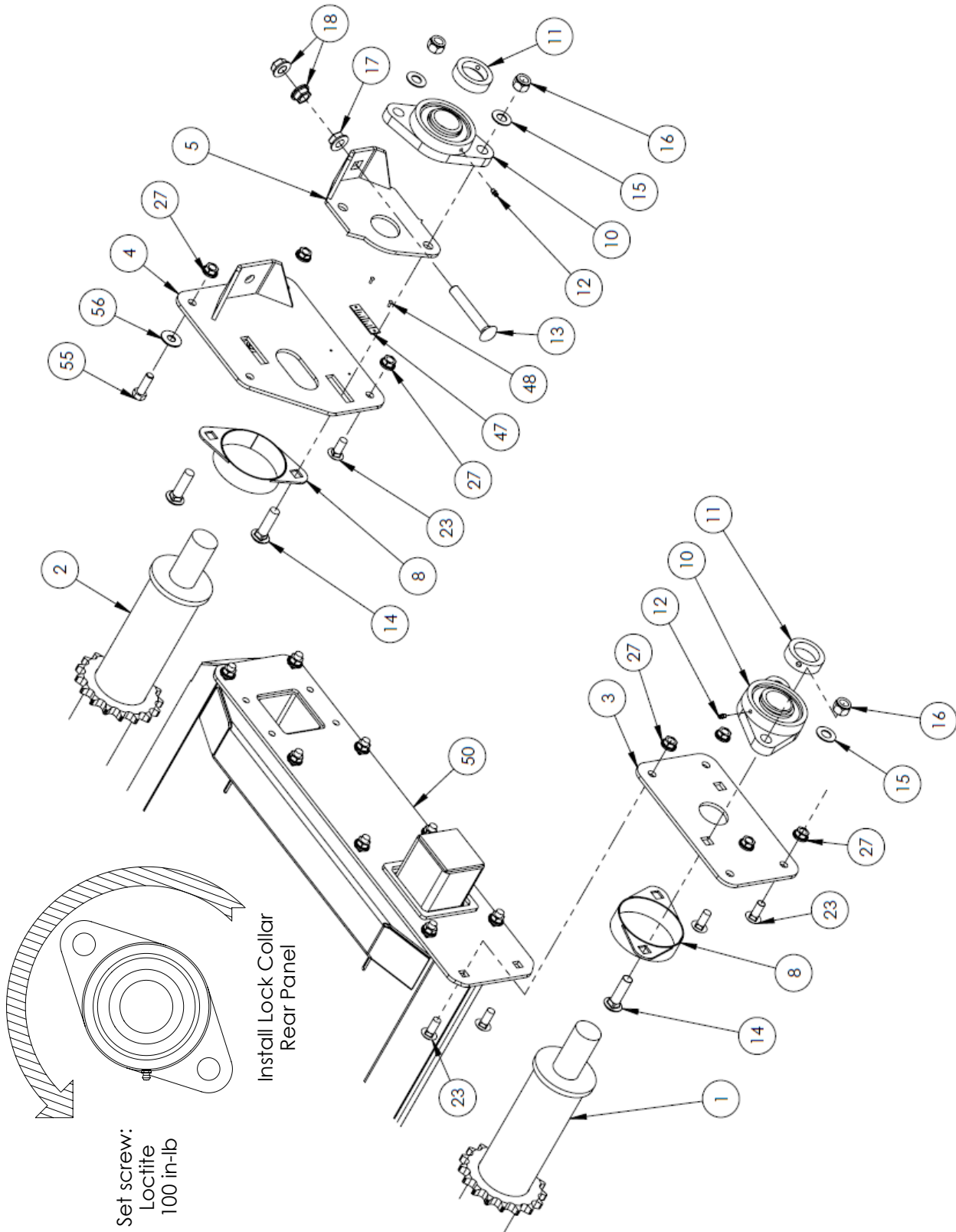



Chain & Slat Rear Panel

See reference table page 60

S/N BK7408 - 7427

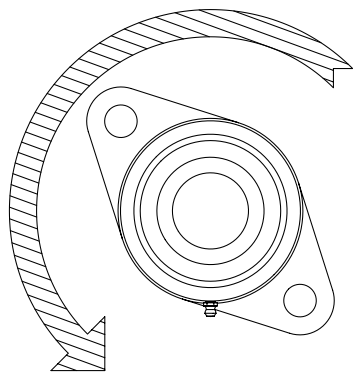
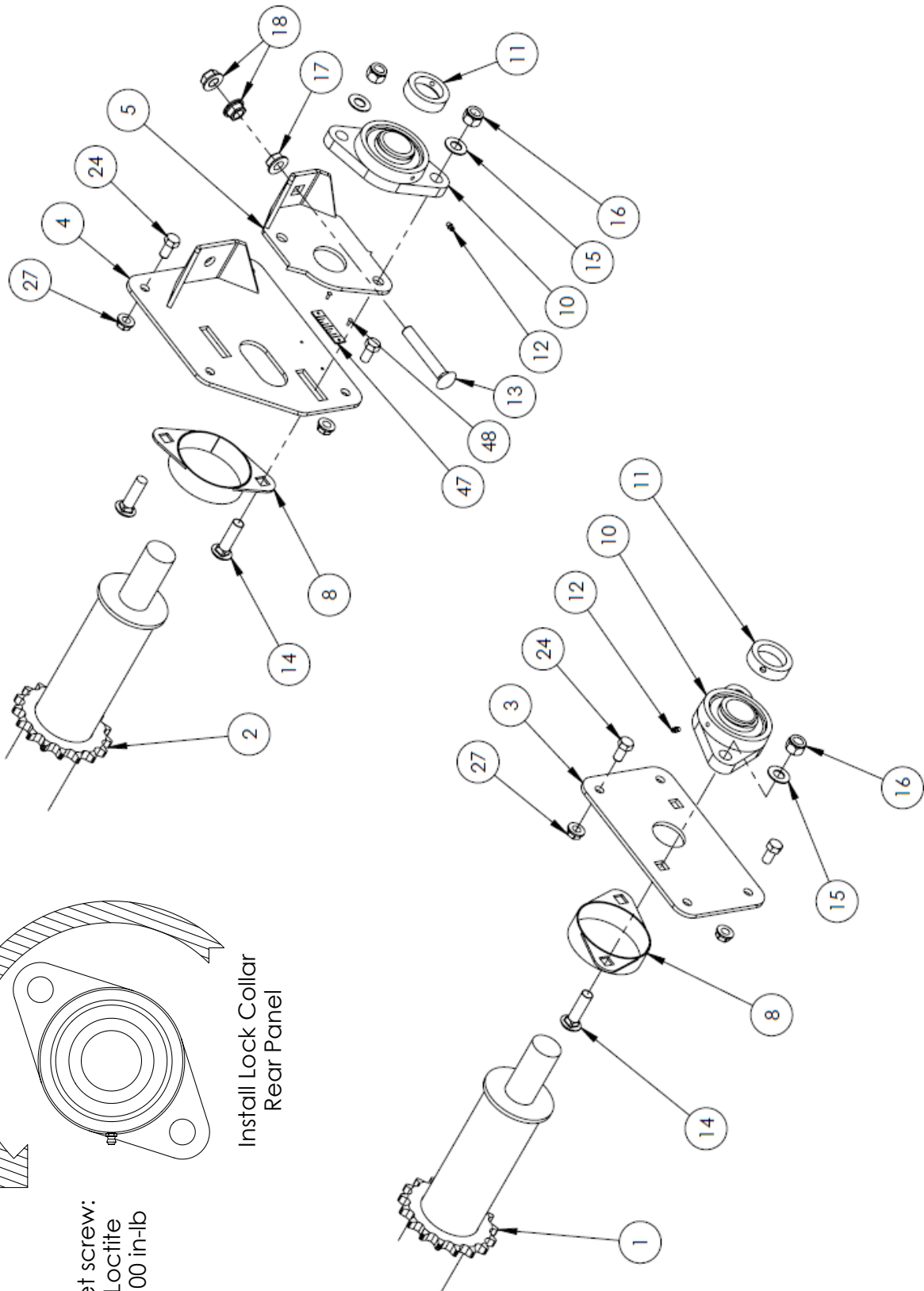

Install Lock Collar
Rear Panel

Set screw:
Loctite
100 in-lb



Chain & Slat Access Panel

See reference table page 60

S/N BK7428 & up

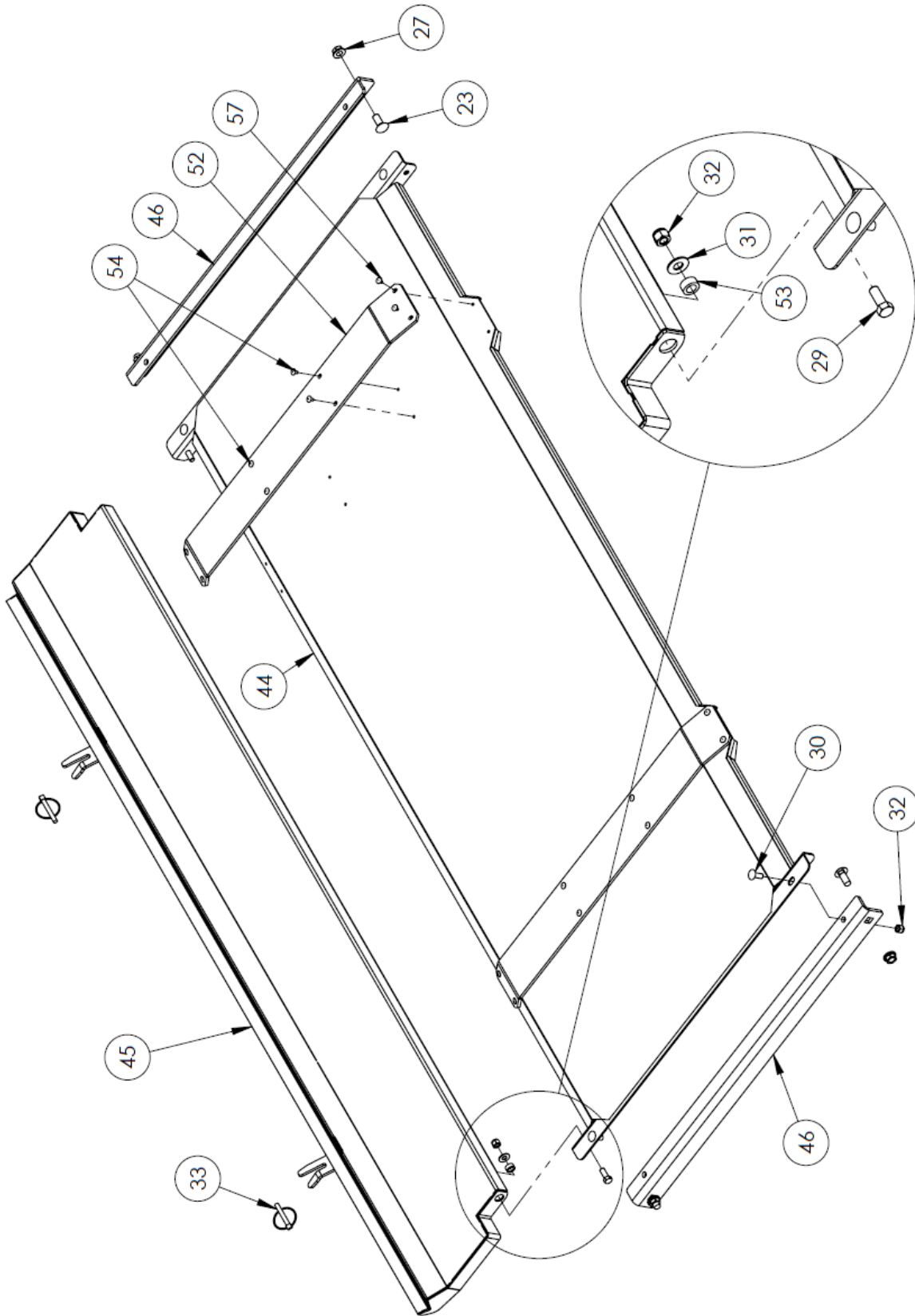



Chain & Slat Access Panel

See reference table page 60

S/N BK7408 - 7427

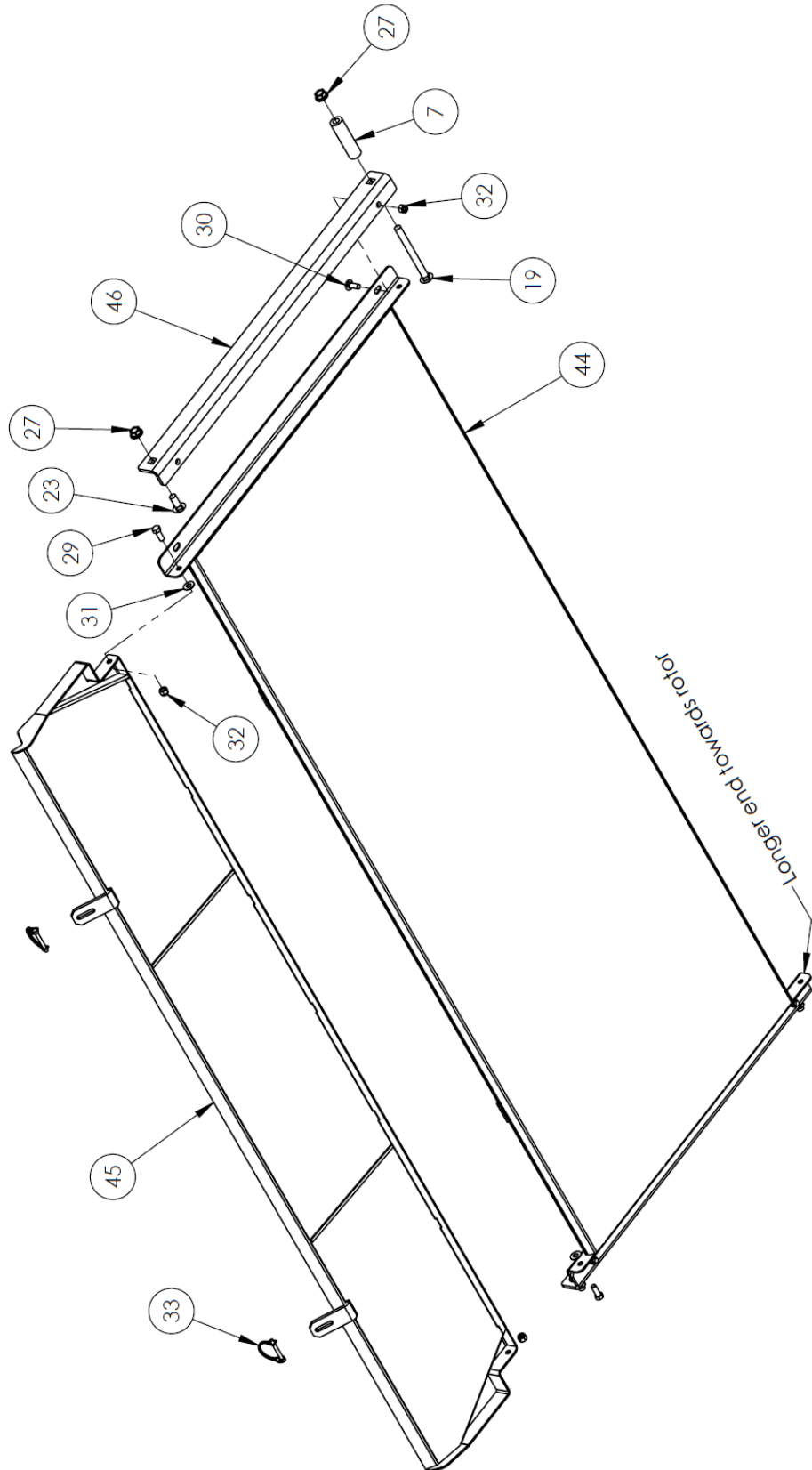



Chain & Slat Assembly

See reference table page 60

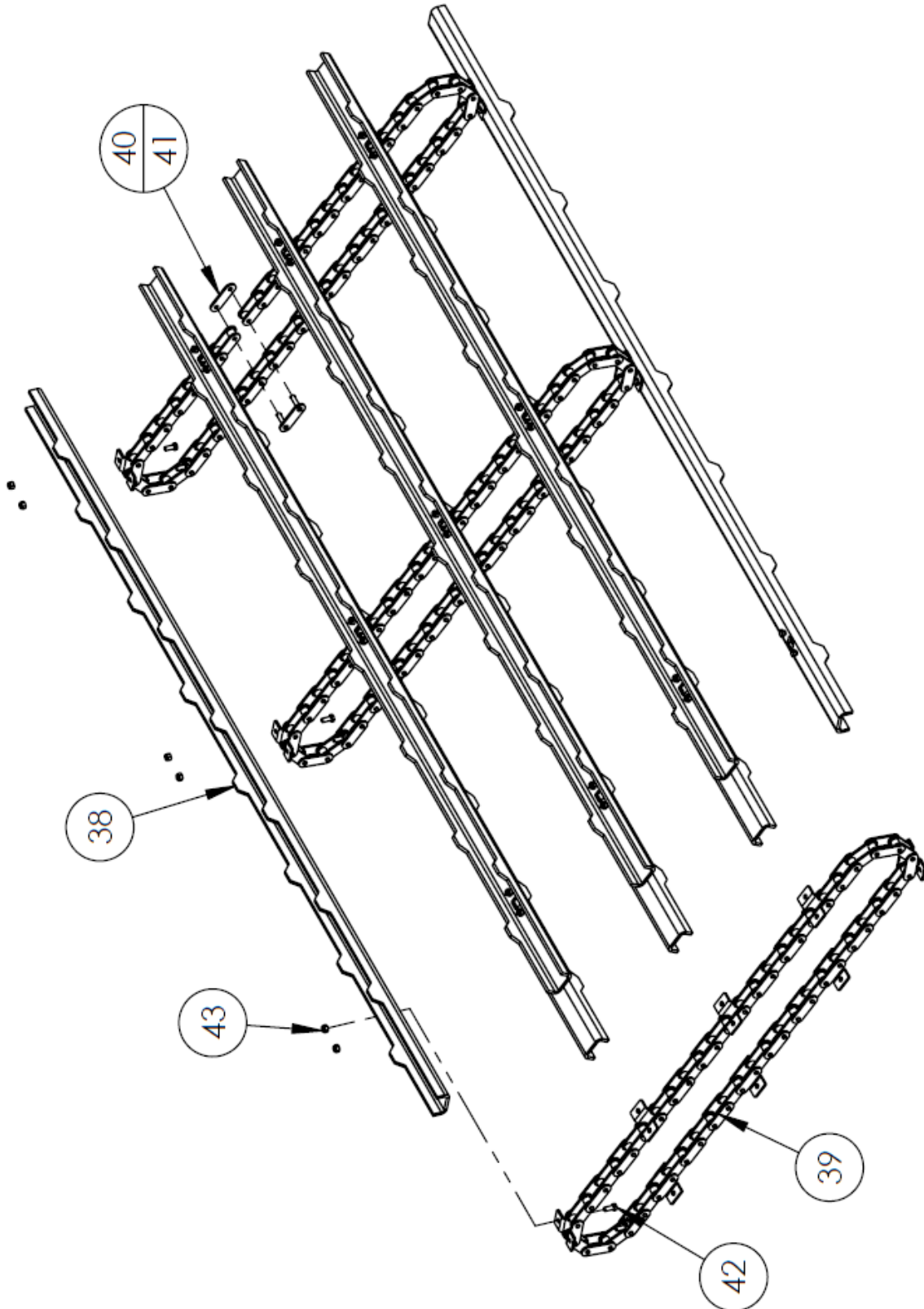



Hoop Grates

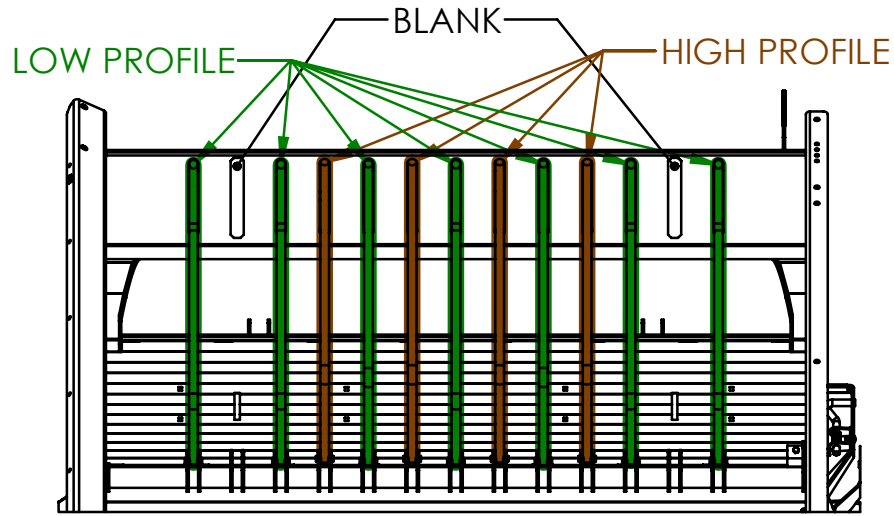

FACTORY HOOP LAYOUT

	Description	ID #	QTY		Description	ID #	QTY
1	Lower Hoop Adjustment Pipe	33749	1	21	Bushing, 1" ID x 1-1/2"	33003	1
2	Lower Hoop Rocker Shaft	33750	1	22	Pivot Bushing, 3/4" ID x 1/2"	33756	4
3	Top Hoop Adjustment Pipe	33748	1	23	Bolt, 3/4 x 2"	13800	4
4	Hoop Handle Linkage	33706	1	24	Washer, 3/4" Flat	13717	4
5	Hoop Handle Pivot	33704	1	25	Washer, 3/4" Lock	13795	2
6	Lower Deflector Handle	33716	1	26	Nut, 3/4" Stover Lock	11823	2
7	Lower Hoop Handle	33705	1	27	Bolt, 1/2 x 1-1/2"	10174	1
8	Hoop Handle Spring Support	33693	2	28	Bolt, 1/2 x 1"	10824	3
9	Lower Deflector Cam <i>See breakdown page 75</i>	33707	1	29	Flanged Bushing, 1/2" ID x 5/8"	33002	1
10	Low-Profile Hoop with Retainer <i>Includes 11, 12, 34, 38</i>	33833	7	30	Washer, 1/2" Fender	10238	3
11	Low-Profile Hoop	33746	7	31	Washer, 1/2" Flat	11668	1
12	Hoop Clamp	33747	11	32	Washer, 1/2" Lock	14447	3
13	Spare Hoop Plug <i>S/N BK7538 & up</i> <i>S/N BK7408 - 7537</i> <i>Includes 14, 15, 38</i>	35248 33834	2	33	Nut, 1/2" Stover Lock	20154	1
14	Spare Hoop Plug	NSS	2	34	Bolt, 3/8 x 2"	10279	23
15	Spare Hoop Plug Clip	NSS	2	35	Bolt, 3/8 x 1-3/4"	16040	-
16	Hoop Handle S-Pin	22187	3	36	Bolt, 3/8 x 1"	13806	4
17	Compression Spring	34465	3	37	Bolt, 3/8 x 1" Carriage	15718	2
18	Roll Pin, 3/16 x 1-1/4"	10302	3	38	Nut, 3/8" Nylon Lock	10806	25
19	Rubber Handle	10297	3	39	Nut, 3/8" Serrated Flange	10271	6
20	Bushing, 1-1/4" ID x 1-3/8"	33234	2	40	High-Profile Hoop with Retainer <i>Includes 41, 12, 34, 38</i>	35249	4
				41	High-Profile Hoop	35197	4



Hoop Grates

See reference table page 69

S/N BK7538 & up

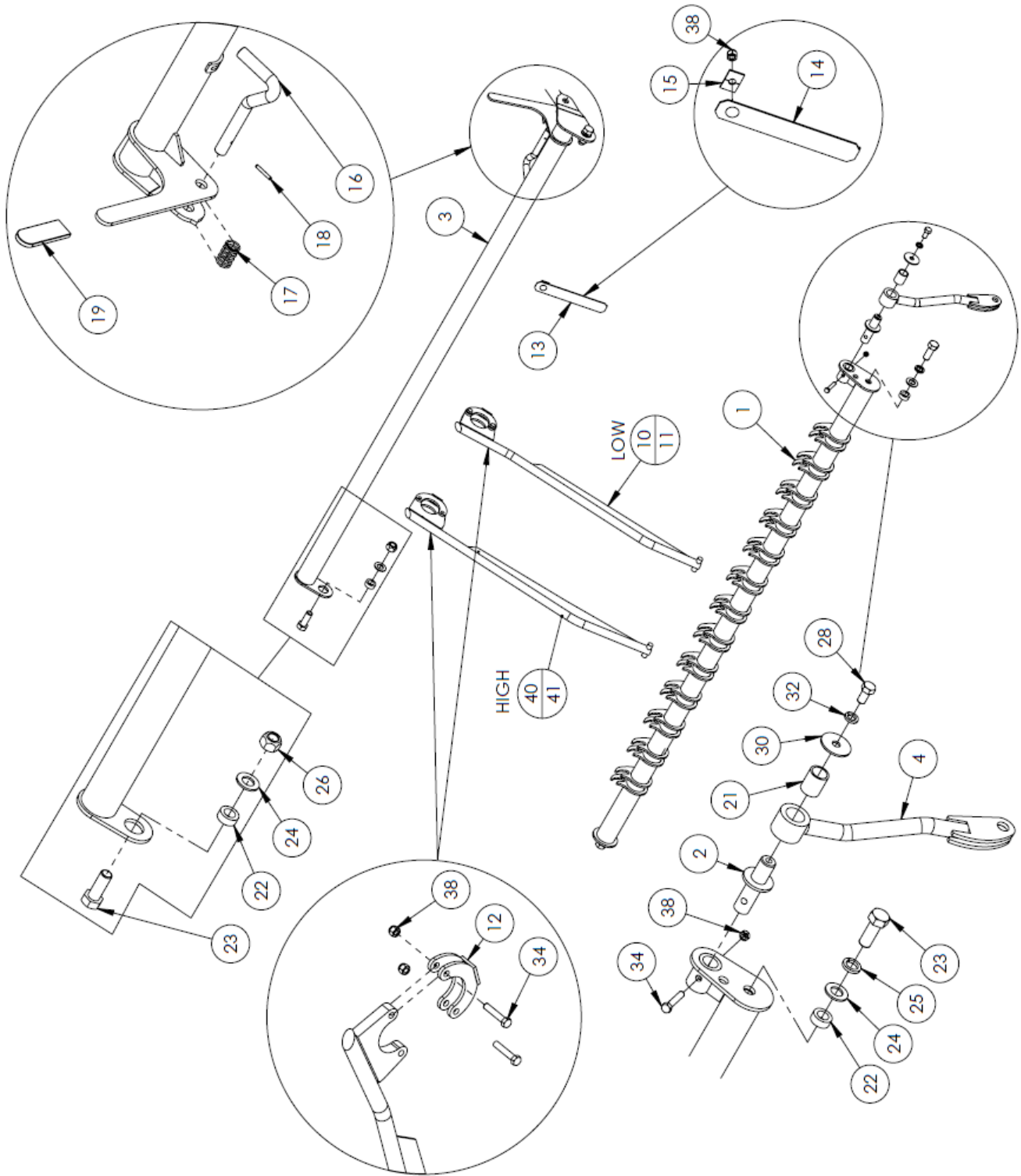



Hoop Grates

See reference table page 69

S/N BK7408 - 7537

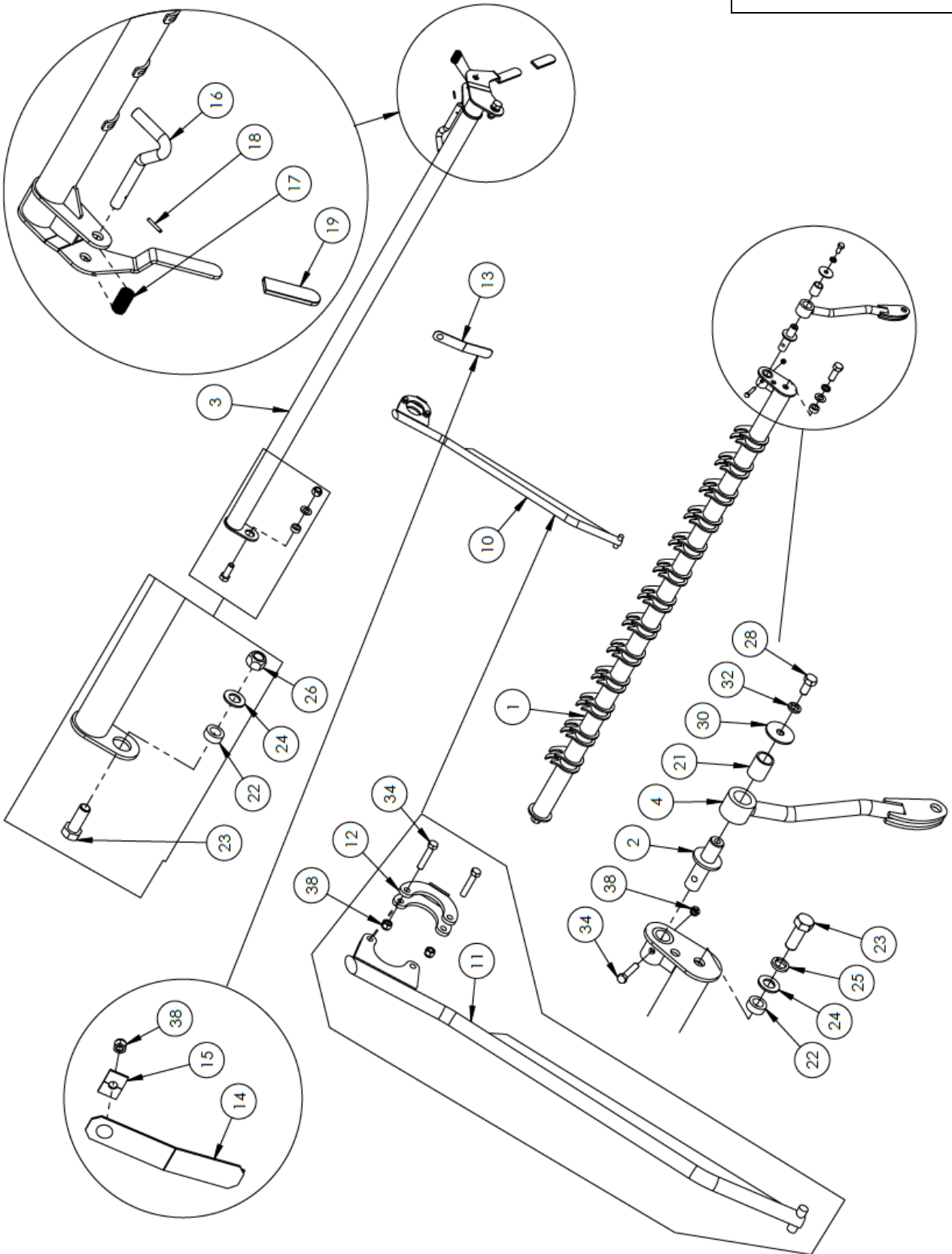



Adjustment Handles

See reference table page 69

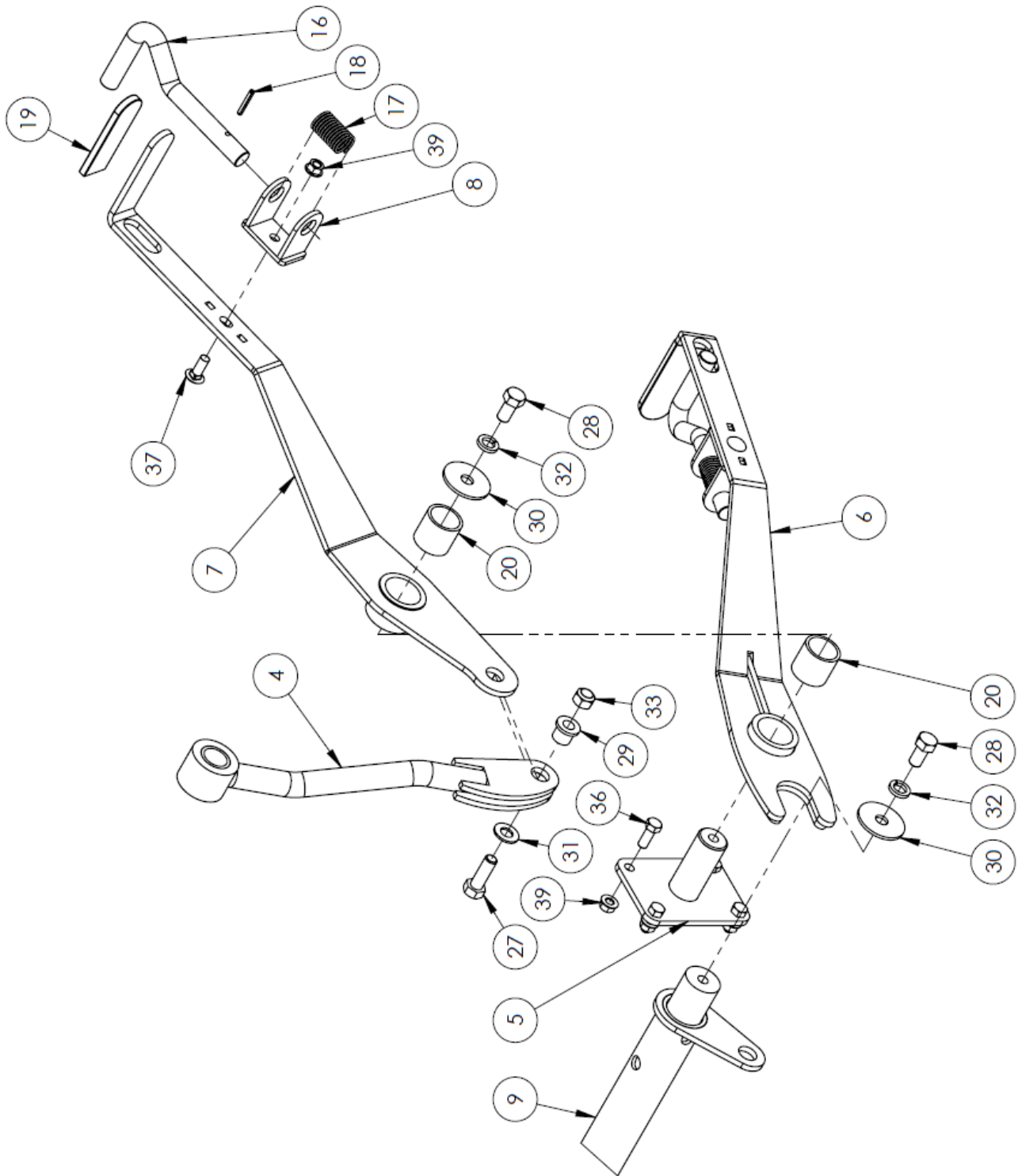



Lower Tub Components

S/N BK7538 & up

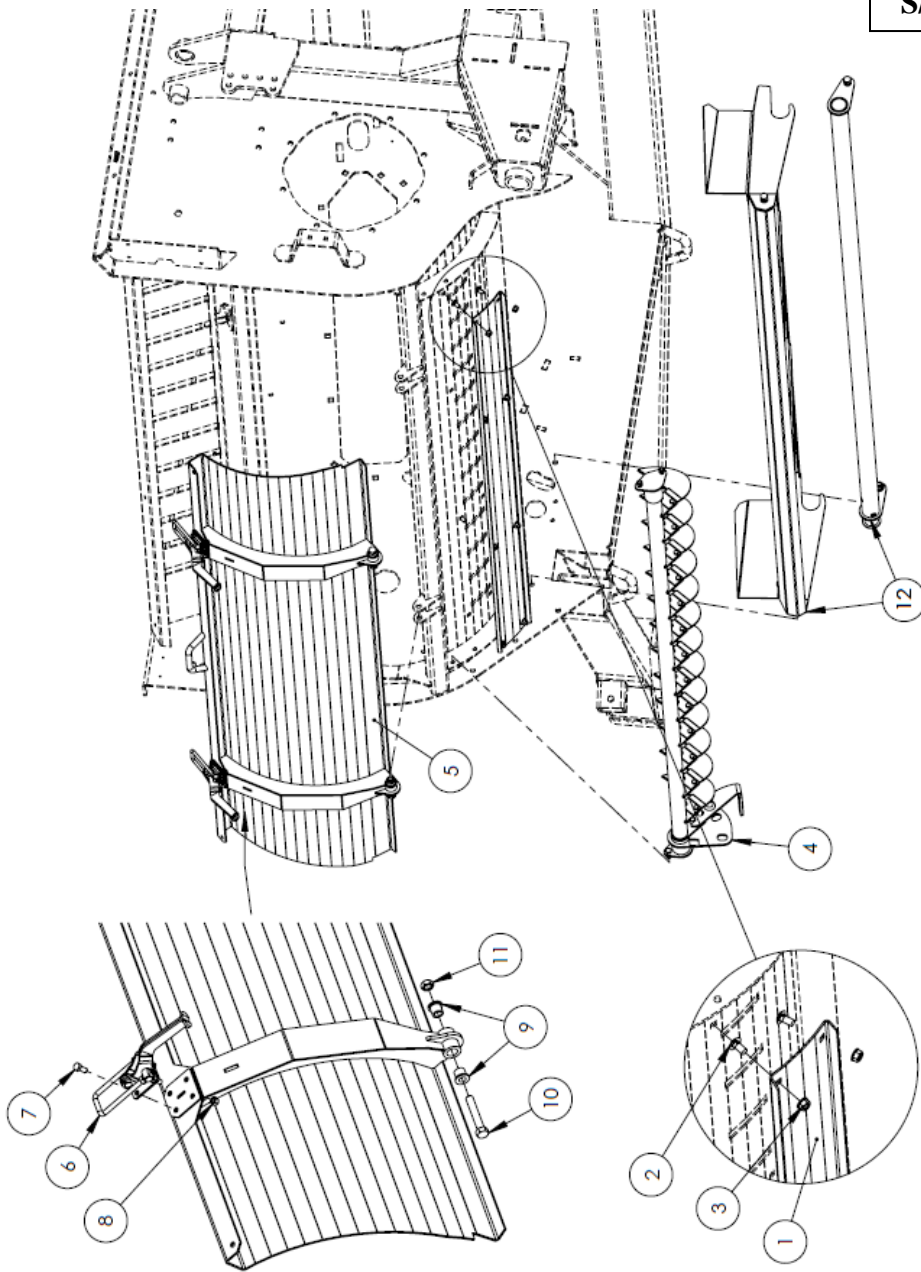

	Description	ID #	QTY		Description	ID #	QTY
1	Fine Chop Cover Plate	33722	1	7	Bolt, 5/16 x 3/4"	20903	8
2	Bolt, 3/8 x 3/4" Carriage	14072	8	8	Nut, 5/16" Nylon Lock	11815	8
3	Nut, 3/8" Serrated Flange	10271	8	9	Flanged Bushing, 1/2" ID x 5/8"	33002	4
4	Fine Chop Option <i>See breakdown page 76</i>	-	-	10	Bolt, 1/2 x 3"	10321	2
5	Rotor Access Door	35195	1	11	Nut, 1/2" Stover Lock	20154	2
6	Toggle Clamp	35136	2	12	Lower Deflector <i>See breakdown page 75</i>	-	-



Lower Tub Components

S/N BK7408 - 7537

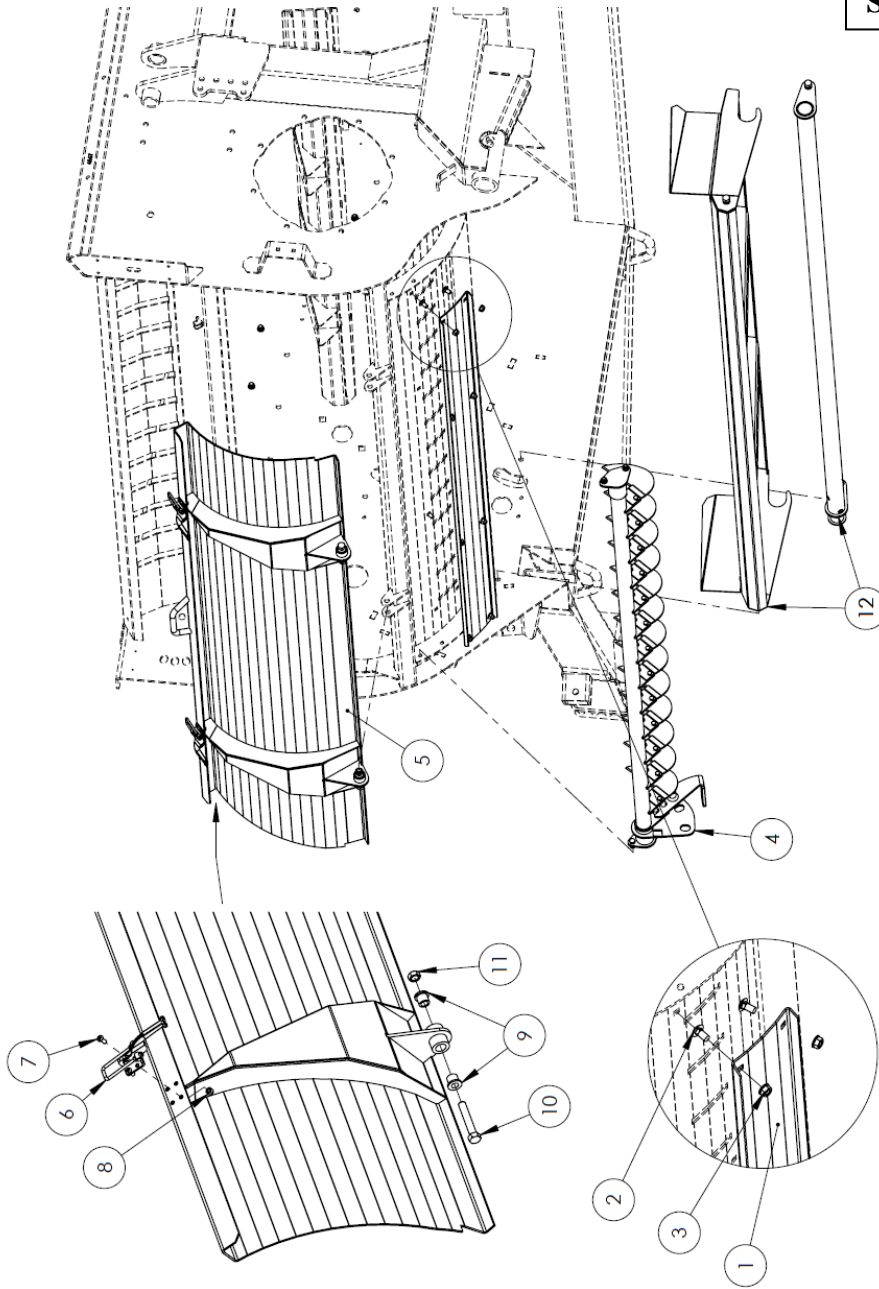

	Description	ID #	QTY		Description	ID #	QTY
1	Fine Chop Cover Plate	33722	1	7	Bolt, #14 x 5/8" Pan Head	13539	8
2	Bolt, 3/8 x 3/4" Carriage	14072	8	8	Nut, 1/4" Nylon Lock	11664	8
3	Nut, 3/8" Serrated Flange	10271	8	9	Flanged Bushing, 1/2" ID x 5/8"	33002	4
4	Fine Chop Option <i>See breakdown page 76</i>	-	-	10	Bolt, 1/2 x 3"	10321	2
5	Rotor Access Door	33700	1	11	Nut, 1/2" Stover Lock	20154	2
6	Toggle Clamp	33001	2	12	Lower Deflector <i>See breakdown page 75</i>	-	-



Lower Deflector

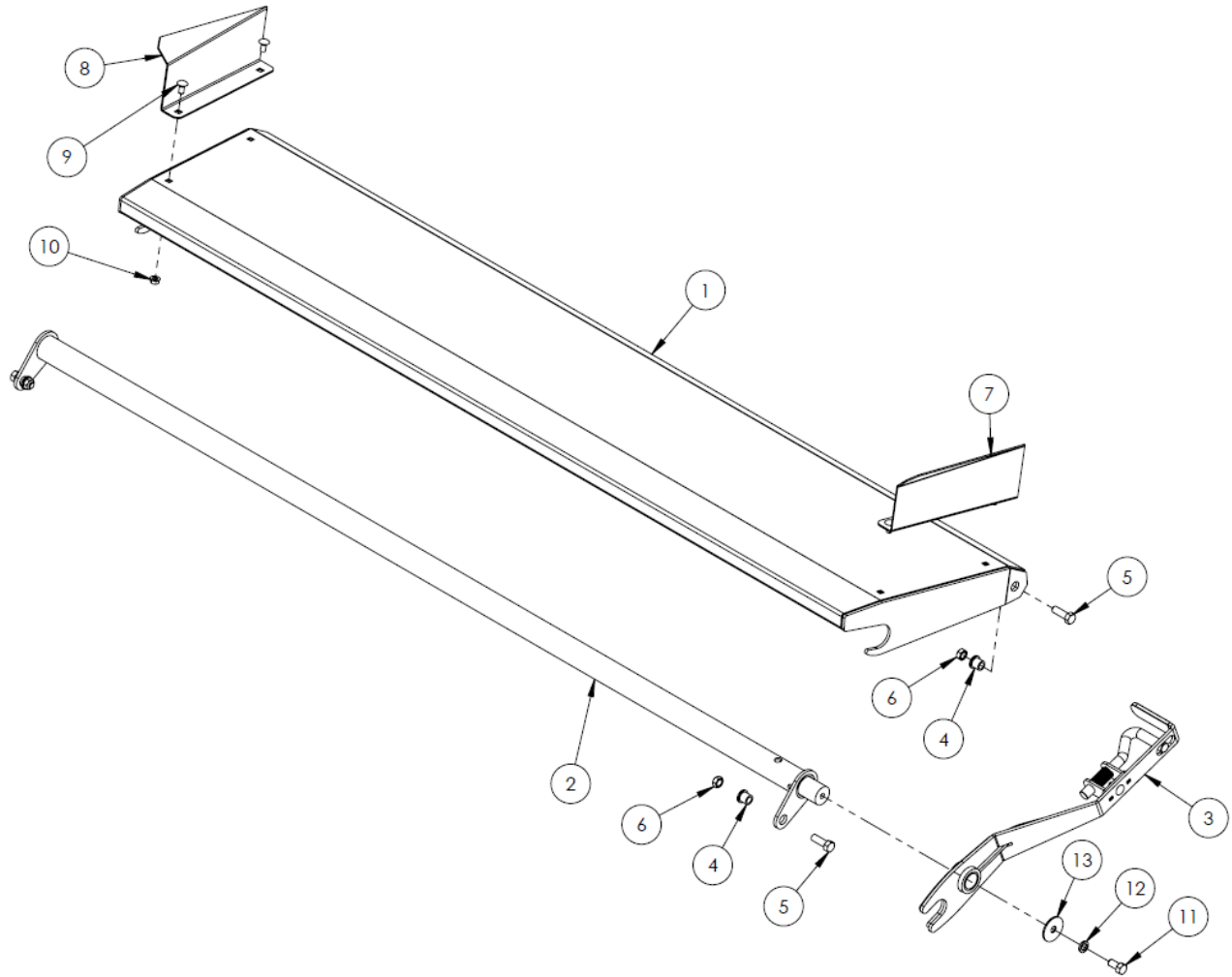

	Description	ID #	QTY		Description	ID #	QTY
1	Lower Deflector	33717	1	7	Lower Deflector Vein Front	33731	1
2	Lower Deflector Cam	33707	1	8	Lower Deflector Vein Rear	33641	1
3	Lower Deflector Handle <i>See breakdown page 72</i>	-	-	9	Bolt, 3/8 x 3/4" Carriage	14072	4
4	Flanged Bushing, 1/2" ID x 5/8"	33002	4	10	Nut, 3/8" Serrated Flange	10271	4
5	Bolt, 1/2 x 1-1/2"	10174	4	11	Bolt, 1/2 x 1"	10824	1
6	Nut, 1/2" Stover Lock	20154	4	12	Washer, 1/2" Lock	14447	1
				13	Washer, 1/2" Fender	10238	1



Fine Chop Option

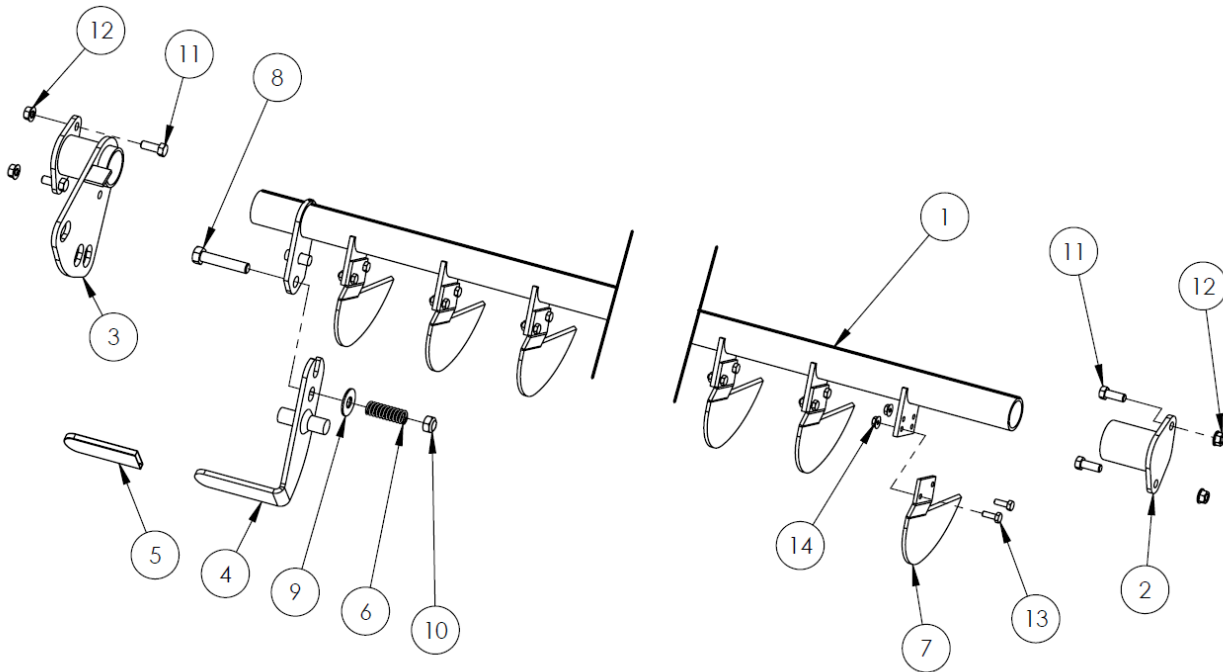

	Description	ID #	QTY		Description	ID #	QTY
	Complete Kit	33773		8	Bolt, 1/2 x 2-1/2"	10804	1
1	Fine Chop Shaft	33735	1	9	Washer, 1/2" Flat	11668	1
2	Fine Chop Pivot Rear	33741	1	10	Nut, 1/2" Stover Lock	20154	1
3	Fine Chop Pivot Front	33738	1	11	Bolt, 3/8 x 1"	13806	4
4	Fine Chop Handle	33740	1	12	Nut, 3/8" Nylon Lock	10806	4
5	Rubber Handle Cover	10297	1	13	Bolt, 1/4 x 3/4"	11809	26
6	Spring	21713	1	14	Nut, 1/4" Nylon Lock	11664	26
7	Fine Chop Knife	10404	13				





Deflector

	Description	ID #	QTY		Description	ID #	QTY
1	Inner Deflector	33708	1	12	Cylinder Pin	22007	2
2	Deflector Pivot	33715	2	13	Cotter Pin, 3/16 x 1-1/4"	11669	4
3	Outer Deflector	31754	1	14	Threaded Pin, 1/2 x 2-1/2"	13231	1
4	Rubber Flipper	24463	1	15	Lynch Pin	13233	1
5	Rubber Flipper Pin	24464	1	16	Bolt, 1/2 x 2"	10322	1
6	Deflector Rubber	10426	1	17	Bolt, 1/2 x 1"	10824	12
7	Deflector Rubber Support	22423	1	18	Nut, 1/2" Serrated Flange	10273	16
8	Deflector Lock Bar	22422	1	19	Bolt, 3/8 x 1"	13806	8
9	Spring	24461	1	20	Bolt, 3/8 x 3/4" Carriage	14072	8
10	Roll Pin, 3/16 x 1-1/4"	10302	1	21	Nut, 3/8" Nylon Lock	10806	8
11	Hydraulic Cylinder <i>Seal kit</i>	21711 23738	1	22	Nut, 3/8" Serrated Flange	10271	8
				23	Hydraulic Fitting, 6MB-6MJ Orifice	17436	2

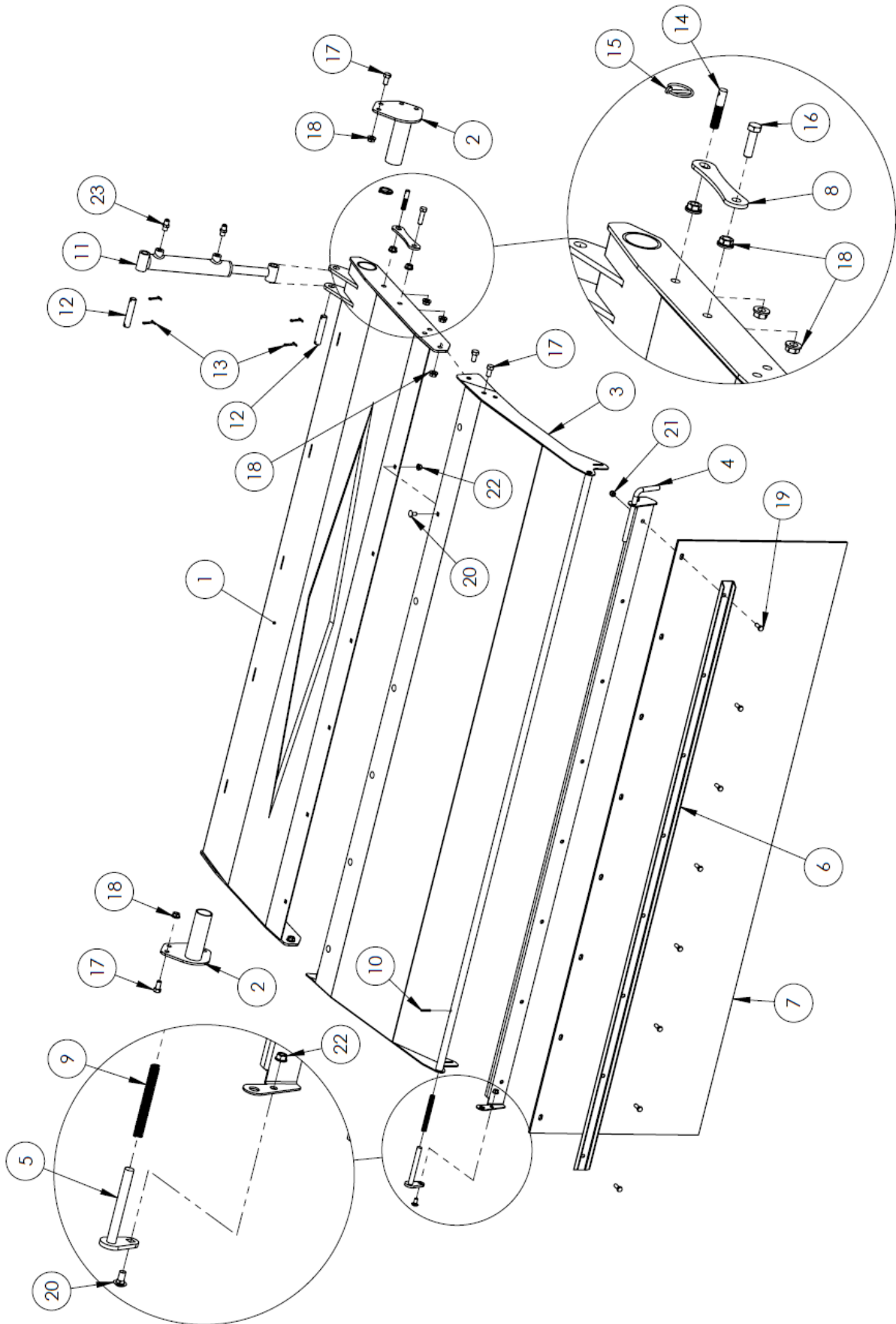



Upper Tub Components

	Description	ID #	QTY		Description	ID #	QTY
1	Rotor-Side Wing	33701	1	8	Nut, 1/2" Serrated Flange	10273	17
2	Discharge-Side Wing # S/N BK7428 & up S/N BK7408-7427 #	34327 33702	1	9	Nut, 1/2" Stover Lock	20154	2
				10	Bolt, 3/8 x 3/4"	11816	8
3	Front Rack Frame & Grating Includes 4, 12, 13, 14	33752	1	11	Nut, 3/8" Serrated Flange	10271	8
4	Front Rack Grating	NSS	1	12	Bolt, 5/16 x 3/4" Button Head	32513	11
5	Rear Wing Gusset # S/N BK7428 & up S/N BK7408-7427	34301 33727	1	13	Washer, 5/16" Flat	12496	11
				14	Nut, 5/16" Nylon Lock	11815	11
6	Bolt, 1/2 x 1-1/4"	10240	18	15	Bolt, 1/2 x 1-1/2"	10174	1
7	Washer, 1/2" Flat	11668	11				

If you have any of the following Serial Numbers, contact Bridgeview for replacement discharge wing components:
BK7415, BK7426



S/N BK7428 & up

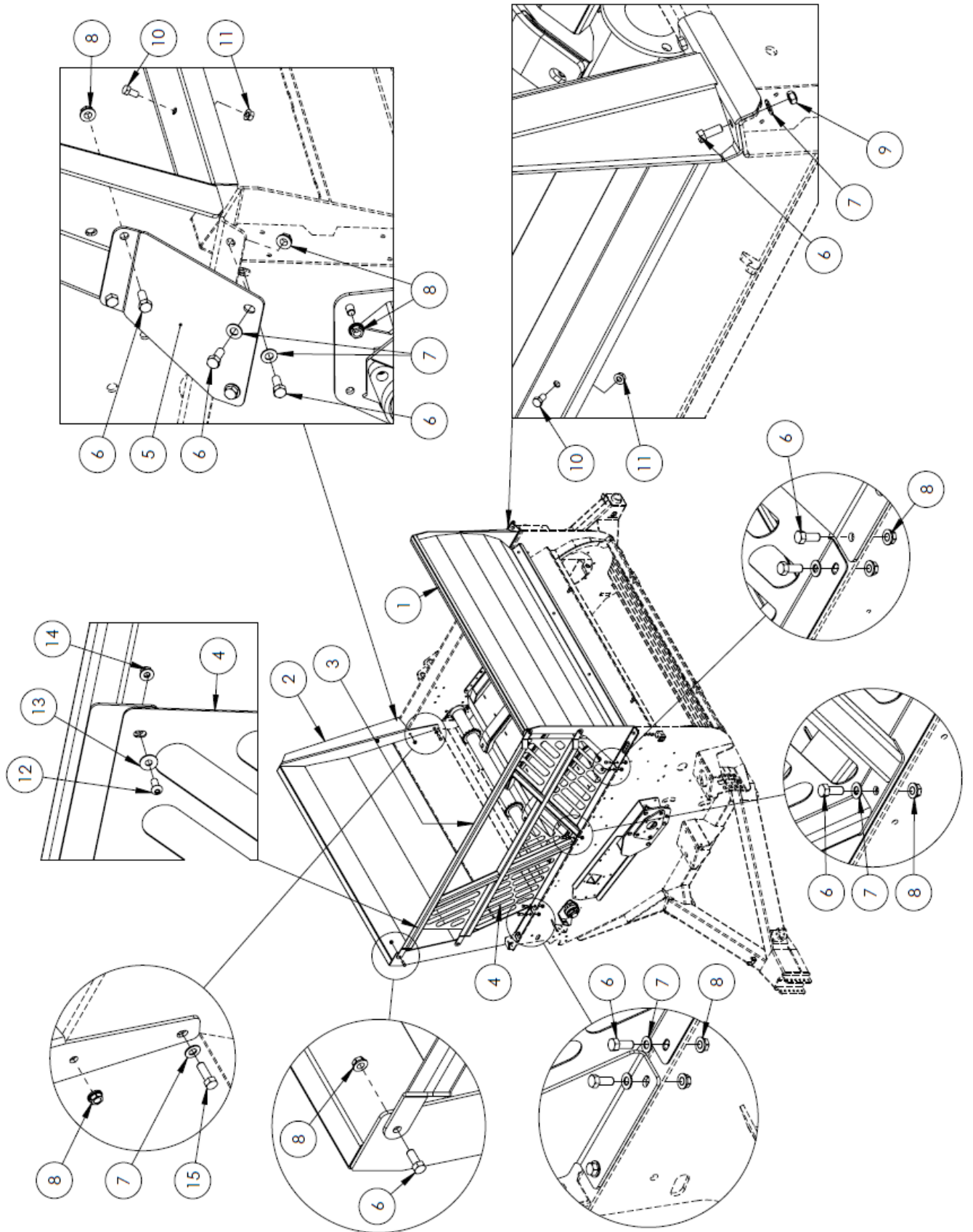



See reference table page 80

S/N BK7408 - 7427

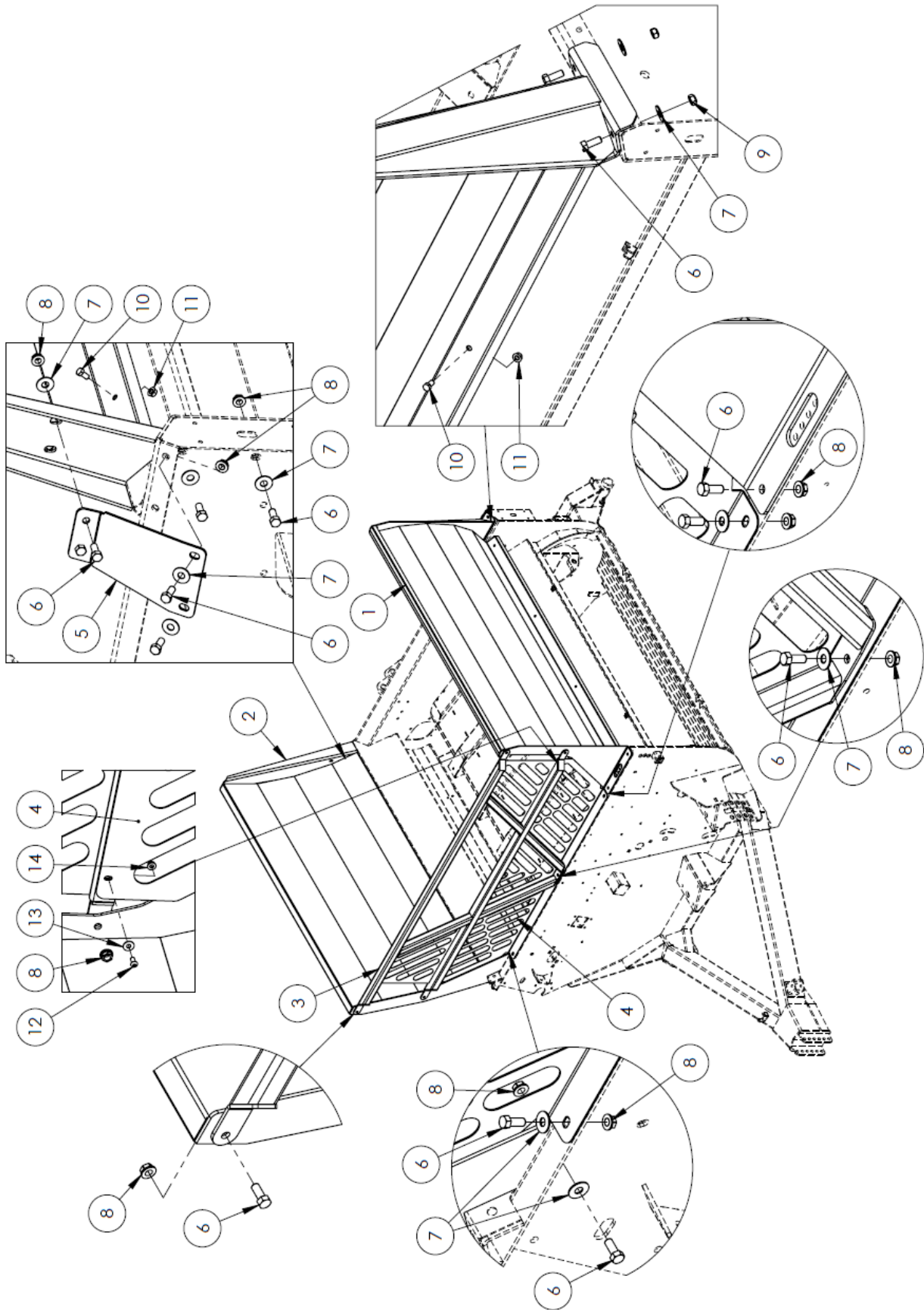





Front Tub Components

	Description	ID #	QTY		Description	ID #	QTY
1	Bulkhead Cover Plate	33721	1	21	Bolt, 5/16 x 2" Bolt	15572	2
2	Flow Control Valve Spacer	33455	1	22	Washer, 5/16" Lock	13766	4
3	Hose Holder	31740	1	23	Nut, 5/16"	19528	4
4	Hose Support Pin	31745	1	24	Nut, 5/16" Nylon Lock	11815	4
5	Manual Holder Box	22409	1	25	Bolt, 1/4 x 2-3/4"	11811	2
6	Line Lock Valve	19114	1	26	Bolt, 1/4 x 3/4"	11809	4
7	Diverter Valve Stacking Kit (Includes 19,22,23) Nut & O-Ring Magnet Kit	11743	2	27	Washer, 1/4" Flat	11666	4
		12895		28	Nut, 1/4" Nylon Lock	11664	6
		17977		29	Hydraulic Fitting, 6MJBH	11767	4
		11789		30	Tapered Plug	33302	1
8	Diverter Valve Plug	13657	2	31	Grommet	21428	1
9	Diverter Valve Wiring See breakdown page 88	24466	1	32	Washer, 5/16" Flat	12496	2
10	Flow Control Valve	10455	1	33	Nut, 3/8" Nylon Lock	10806	4
11	Threaded Pin, 1/2 x 2-1/2"	13231	1	34	Adjustable Hose Holder	35038	1
12	Hairpin	11786	1	35	Adjustable Hose Holder Linkage	35040	1
13	Nut, 1/2" Serrated Flange	10273	2	36	Adjustable Hose Holder Pivot	35041	2
14	Bolt, 3/8 x 2" Fine Thread Gr.5	33285	4	37	Handle Bolt	34944	1
15	Nut, 3/8" Fine Thread Stover Lock	33286	4	38	Washer, 3/8" Heavy Flat	33189	1
16	Bolt, 3/8 x 1" Carriage	15718	5	39	Washer, 3/8" Flat	11667	4
17	Bolt, 3/8 x 1"	13806	4	40	Bolt, 1/2 x 1-1/4"	10240	3
18	Nut, 3/8" Serrated Flange	10271	9	41	Nut, 1/2" Nylon Lock	10241	3
19	Bolt, 5/16 x 5"	NSS	4				
20	Bolt, 5/16 x 3" Socket Head	11783	2				

NOTE: Not all parts shown will be used, depending on the hydraulic remote set-up.



S/N BK7538 & up

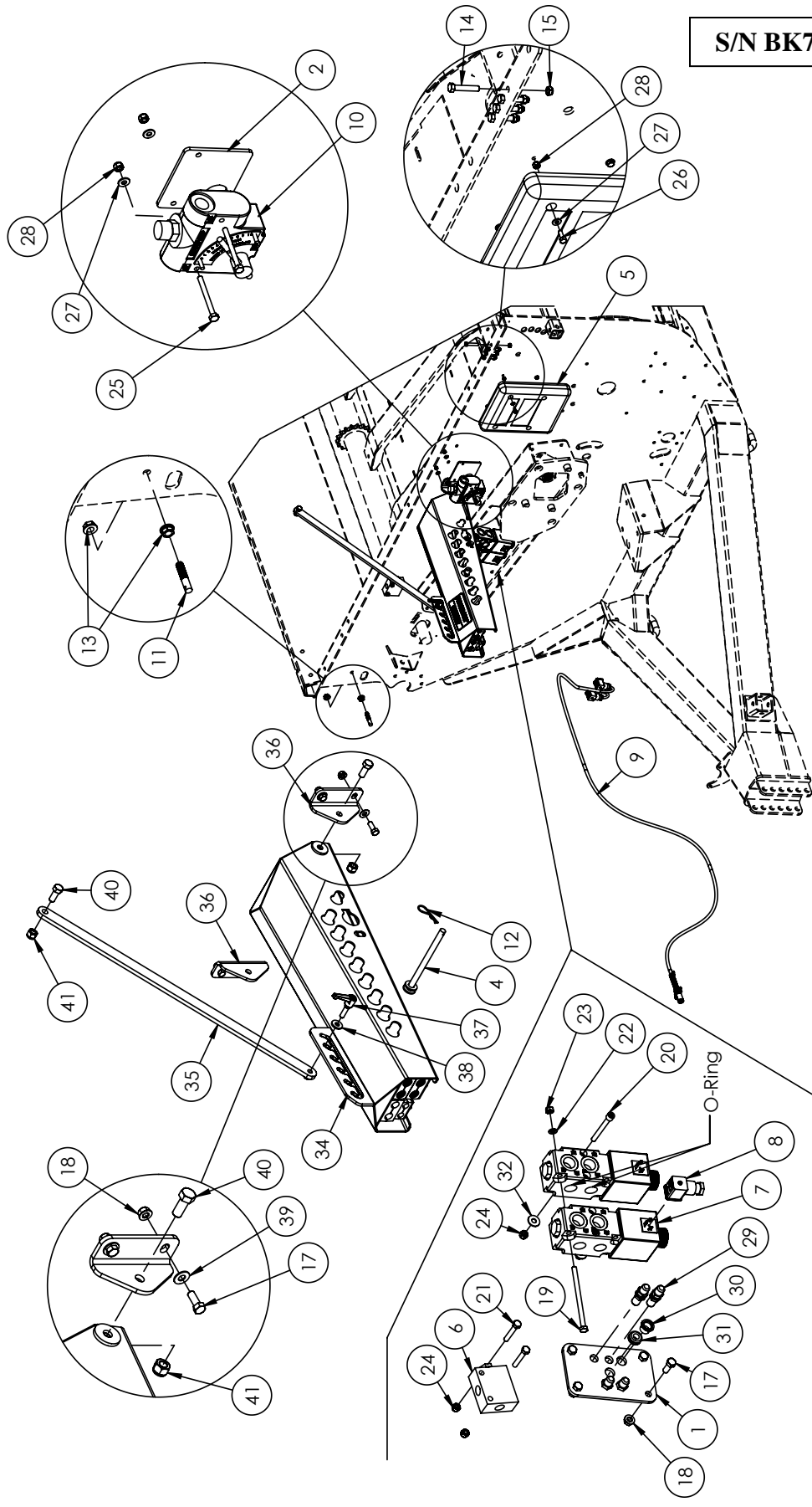



See reference table page 84

S/N BK7408 - 7537

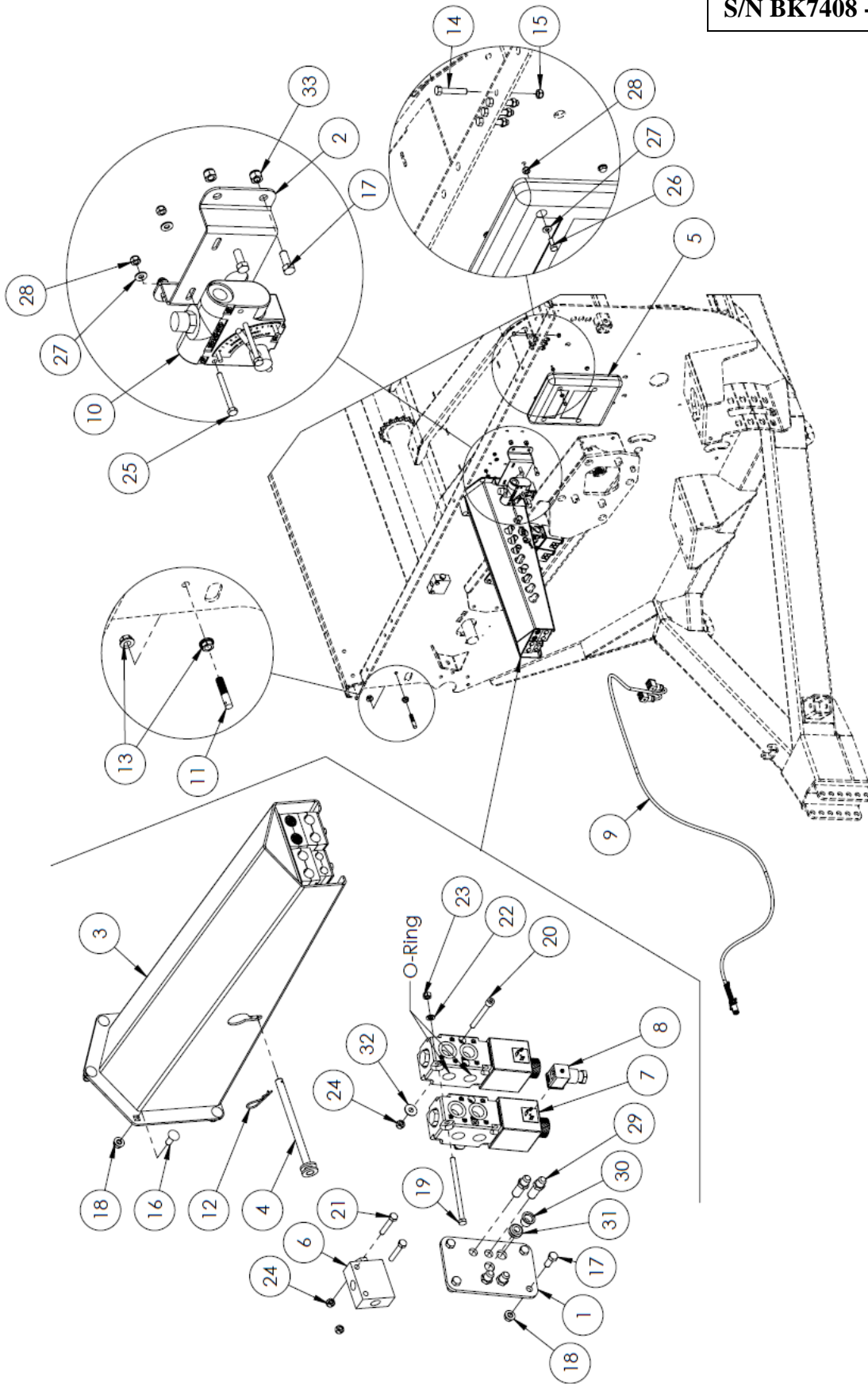



Hose Holder & Hydraulic Clamps

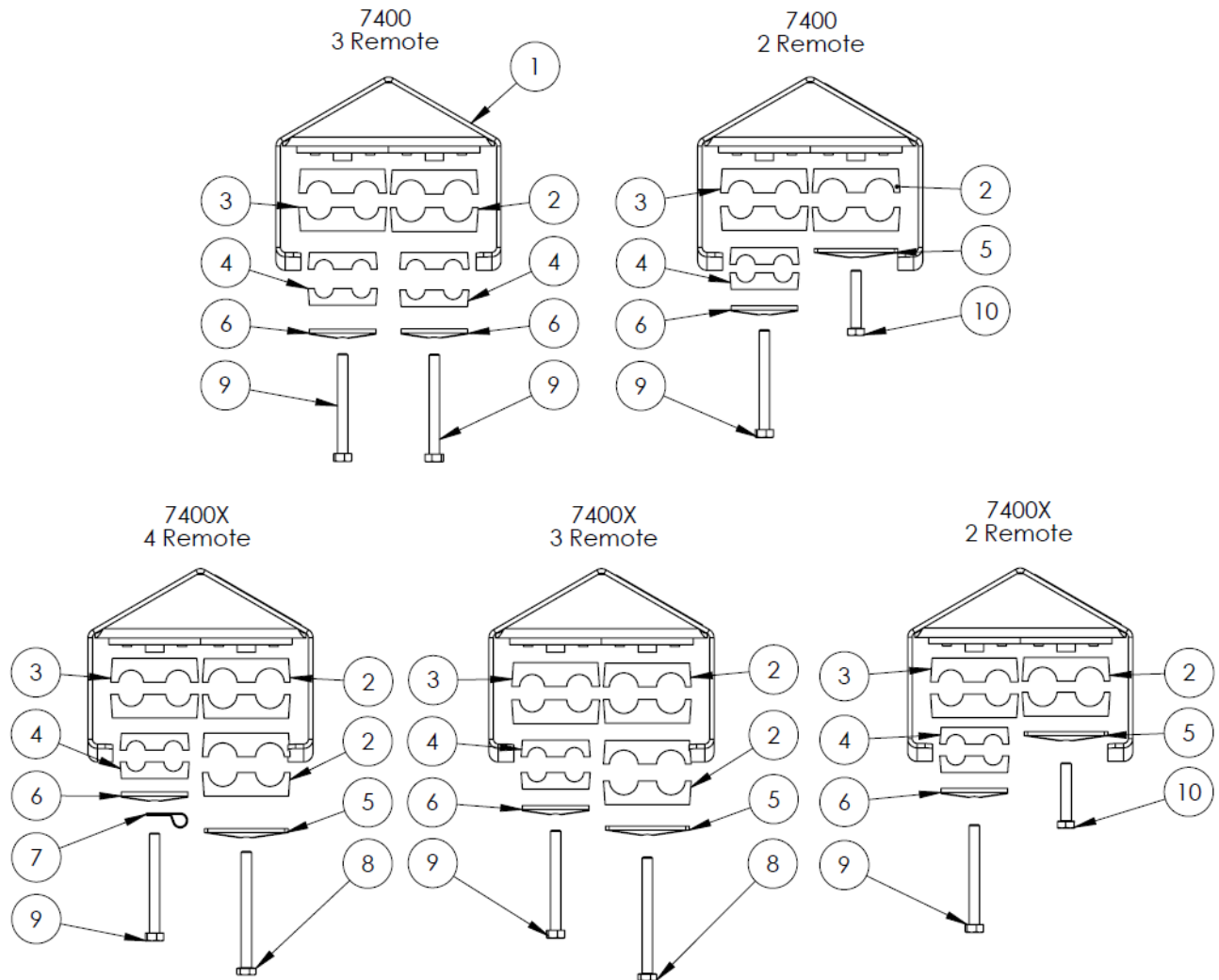

	Description	ID #	QTY		Description	ID #	QTY
1	Hose Holder	31740	1	7	Cable Clamp	13629	A/R
2	Hose Clamp for 1/2" Hose	21561	A/R	8	Bolt, 5/16 x 3-1/2"	13765	A/R
3	Hose Clamp for 3/8" Hose	22180	A/R	9	Bolt, 5/16 x 3"	22844	A/R
4	Hose Clamp for 1/4" Hose	22181	A/R	10	Bolt, 5/16 x 1-3/4"	21726	A/R
5	Hose Clamp Cap Large	21725	A/R	11	Velcro Strap <i>To wrap hoses together</i>	17962	1
6	Hose Clamp Cap Small	22182	A/R				



Diverter Control Box

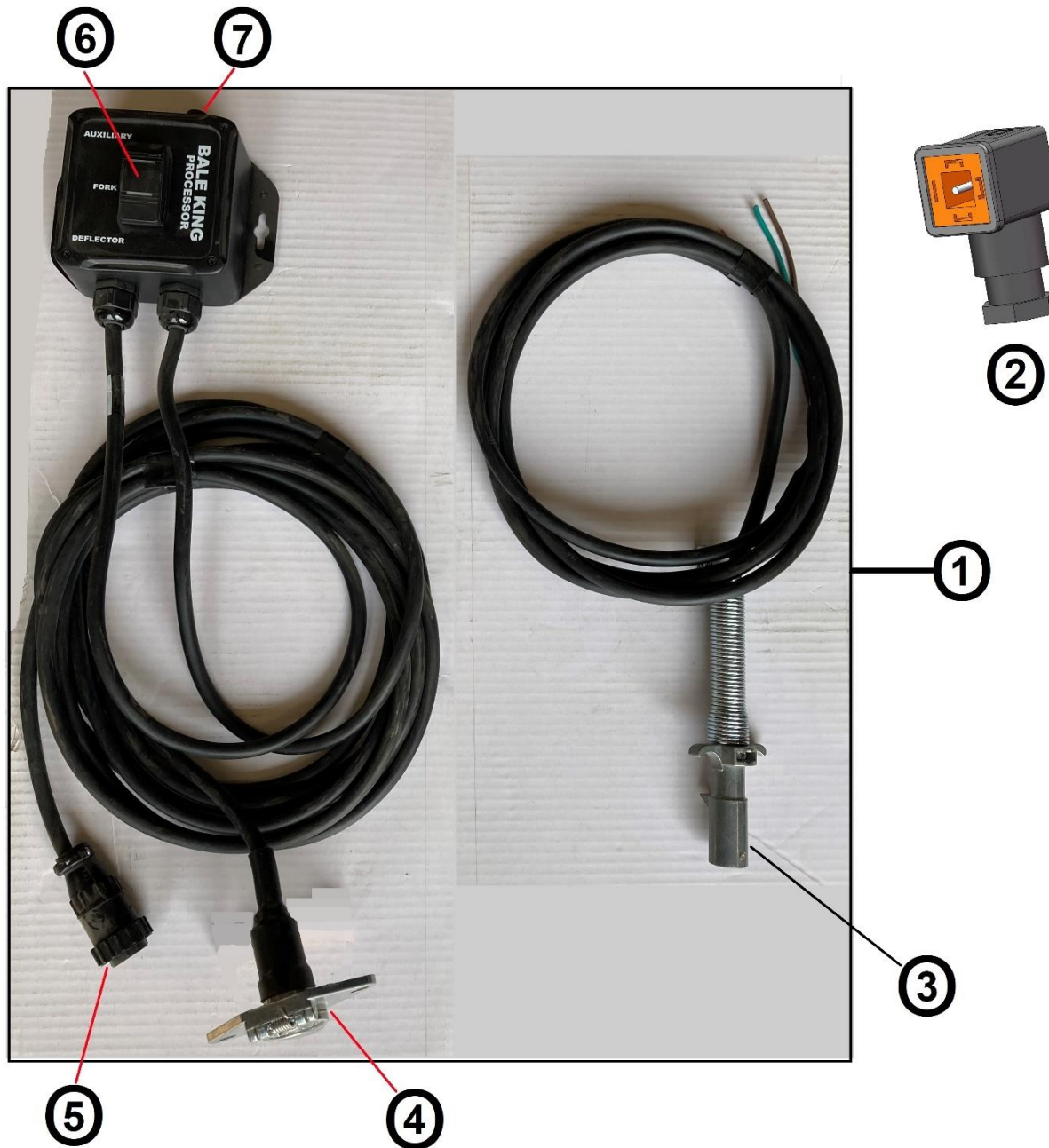

	Description	ID #	QTY		Description	ID #	QTY
1	Complete Control Box with Harness	24466	1	5	3-pin Connector Plug	18537	1
2	Square Plug for Diverter Valve <i>not included in kit</i>	13657	*	6	3-way Switch	13561	1
3	4-pin Trailer Plug	24691	1	7	Fuse Holder	10312	1
4	4-pin Tractor Plug	24690	1				

* NOTE: 1 plug is needed for each diverter valve.



Diverter Control Box #24466

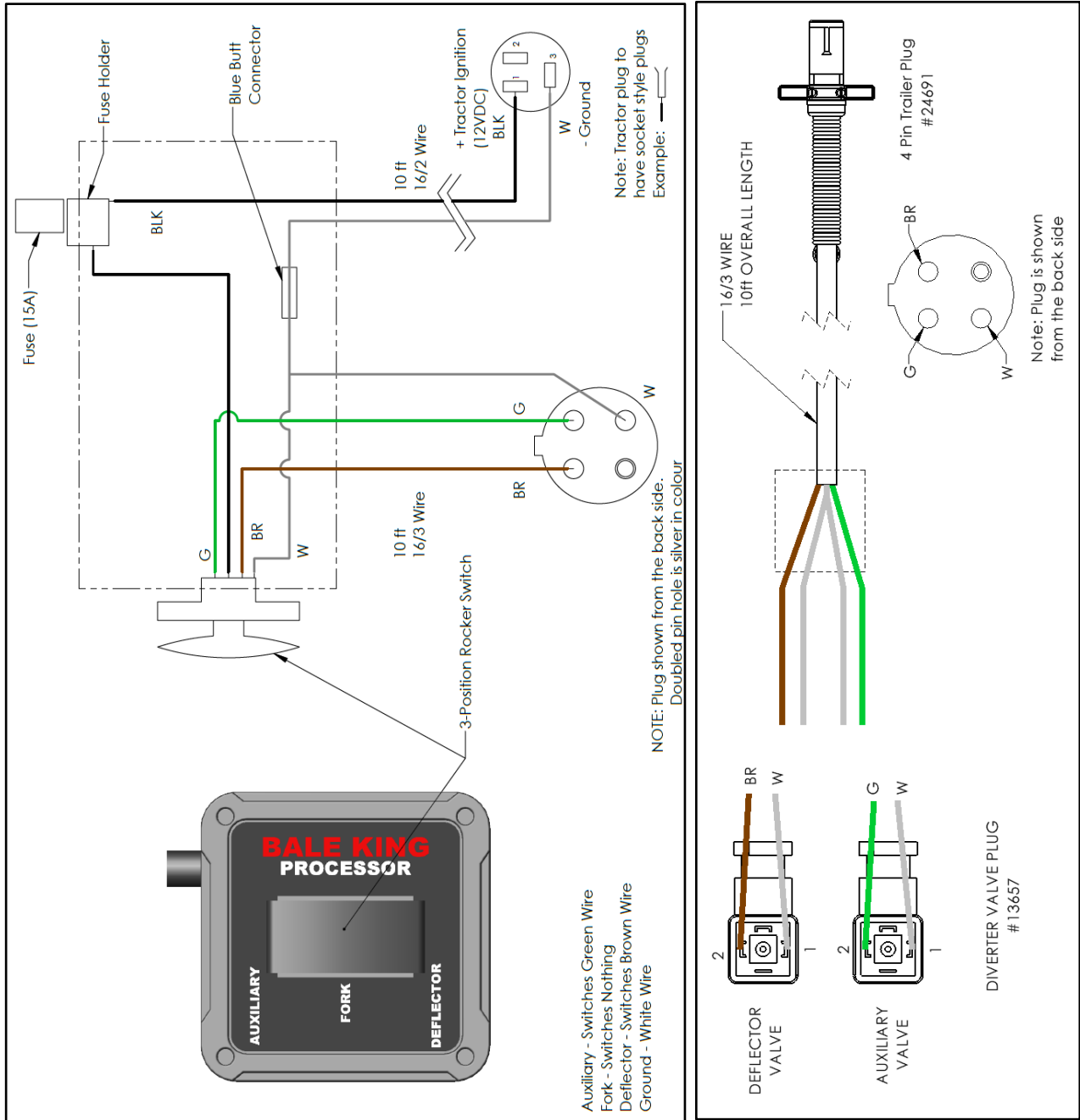



Rear Tub Components

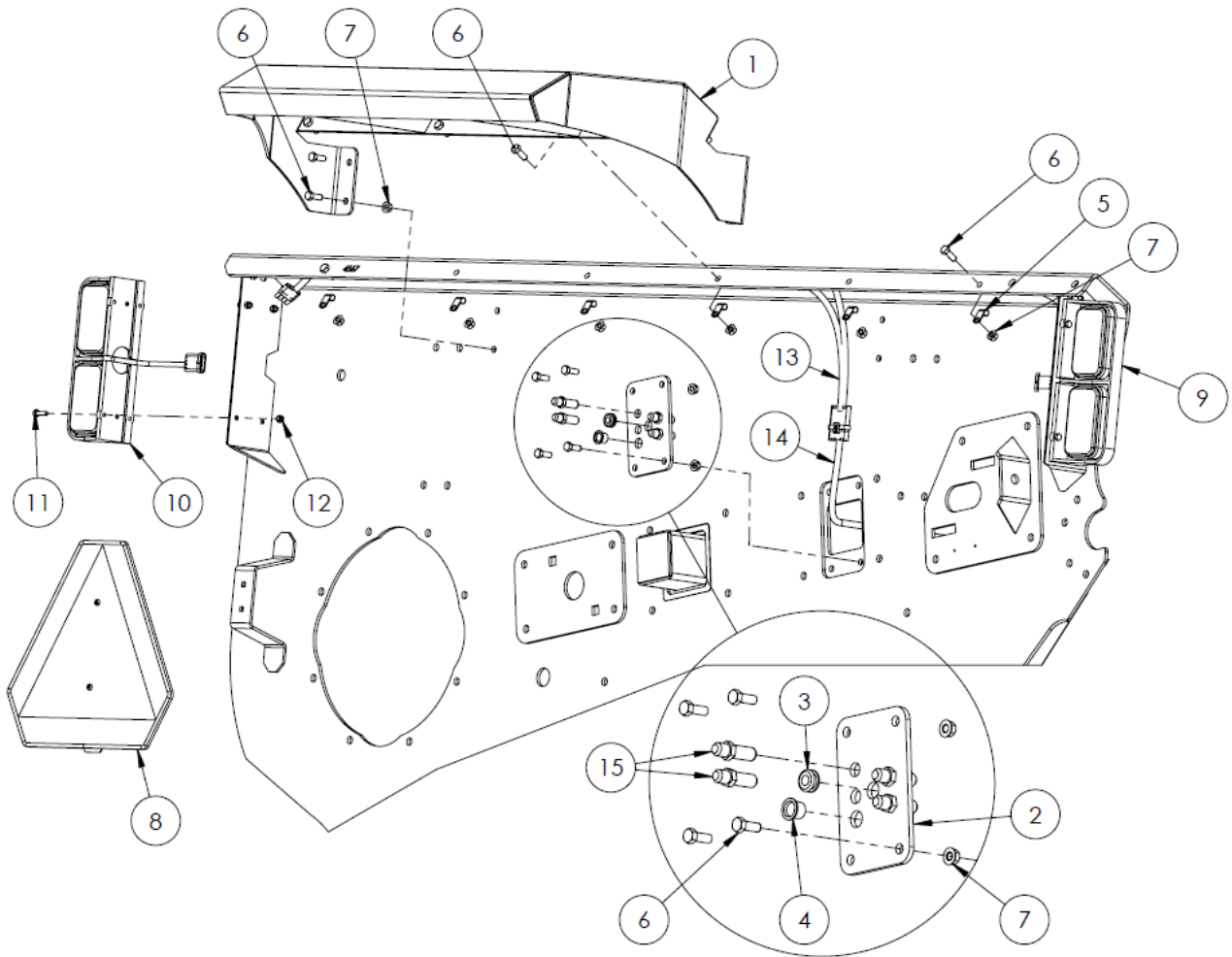

	Description	ID #	QTY		Description	ID #	QTY
1	Rear Deflector	33713	1	9	RH Light	31088	1
2	Bulkhead Cover Plate	33721	1	10	LH Light	31087	1
3	Grommet, 7/16" ID x 1/4" Thick	21428	1	11	Bolt, 1/4 x 1"	11810	4
4	Tapered Plug	33302	1	12	Nut, 1/4" Nylon Lock	11664	4
5	Wiring Clamp	13629	5	13	Wishbone Light Harness	32997	1
6	Bolt, 3/8 x 1"	13806	14	14	Main Light Harness	32998	1
7	Nut, 3/8" Serrated Flange	10271	14	15	Hydraulic Fitting, 6MJBH	11767	4
8	SMV Sign <i>See breakdown page 91</i>	22411	1				



Slow Moving Vehicle (SMV) Sign Kit

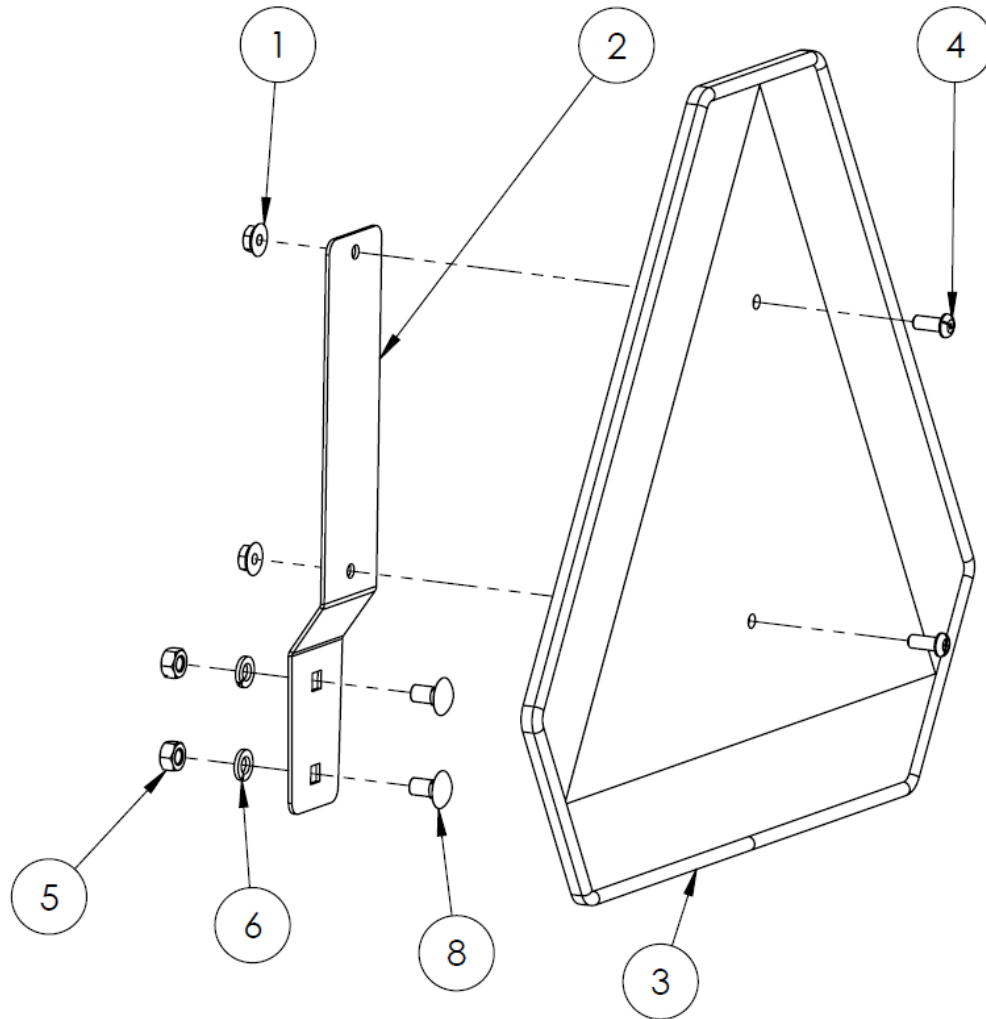

	Description	ID #	QTY		Description	ID #	QTY
	Complete SMV Sign Kit	22411	1	6	Lock Washer, 5/16"		2
1	Nut, 1/4" Nylon Lock Nut	11664	2	7	Tapered Receiver Bracket		1
2	Galvanized Sign Bracket		1	8	Carriage Bolt, 5/16" x 1/2"		2
3	Plastic SMV Sign		1	9	Carriage Bolt, 5/16" x 2"		-
4	Pan Head Bolt, 1/4" x 5/8"		2	10	Lock Washer, 1/4"		-
5	Nut, 5/16"		2				

NOTE: Only the parts shown above are used on the Bale King 7400. Additional parts are included in the SMV sign kit which are not required. Individual parts not sold separately.



Lights

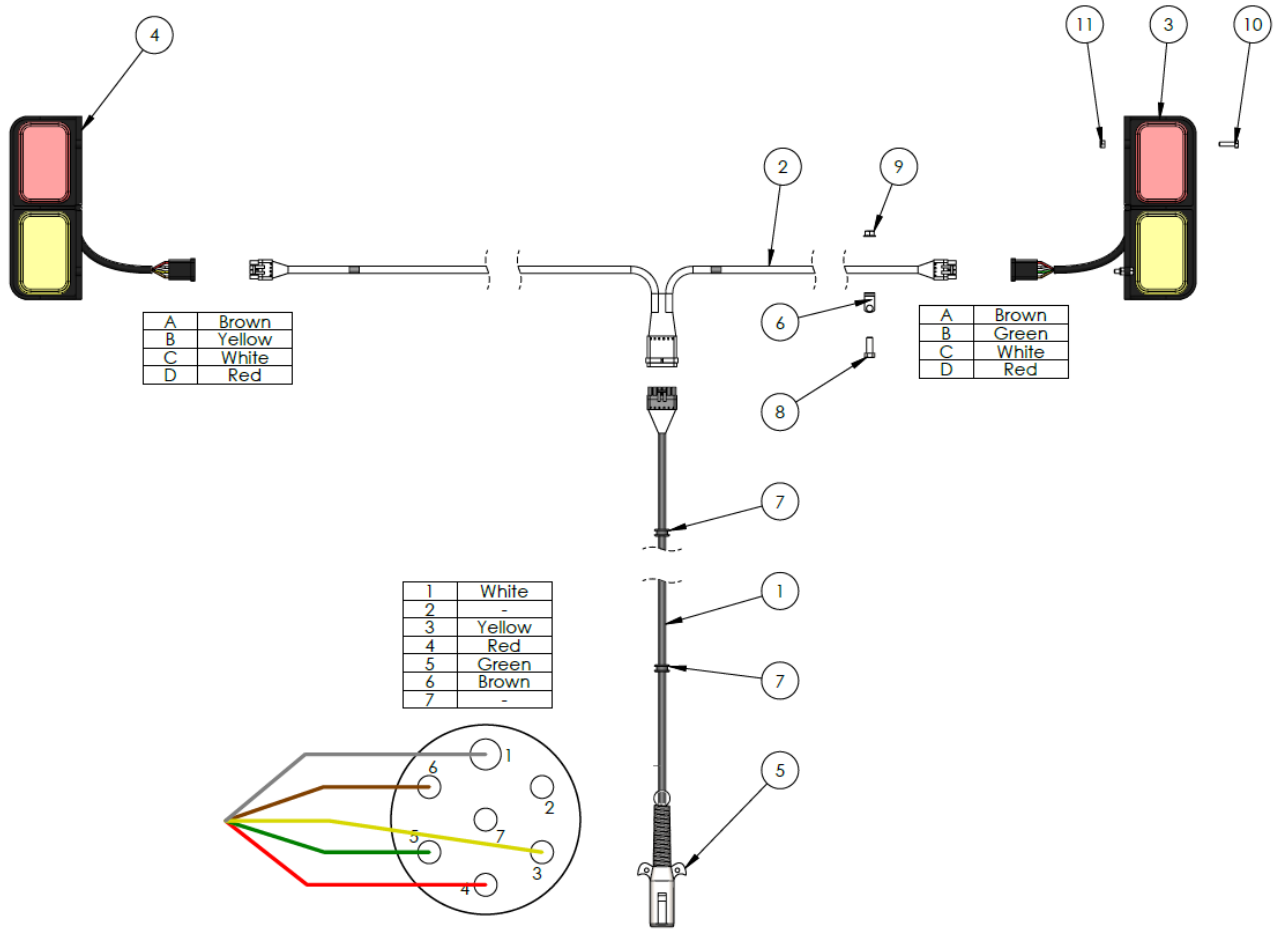

	Description	ID #	QTY		Description	ID #	QTY
1	Main Light Harness	32996	1	7	Grommet	21428	2
2	Wishbone Harness	32997	1	8	Bolt, 3/8 x 1"	13806	6
3	Light Assembly, LH	31087	1	9	Nut, 3/8" Serrated Flange	10271	6
4	Light Assembly, RH	31088	1	10	Bolt, 1/4 x 1"	11664	8
5	7-pin Trailer Plug	12177	1	11	Nut, 1/4" Nylon Lock	11810	8
6	Wire Clamp	13629	6				



Main Light Harness #32996

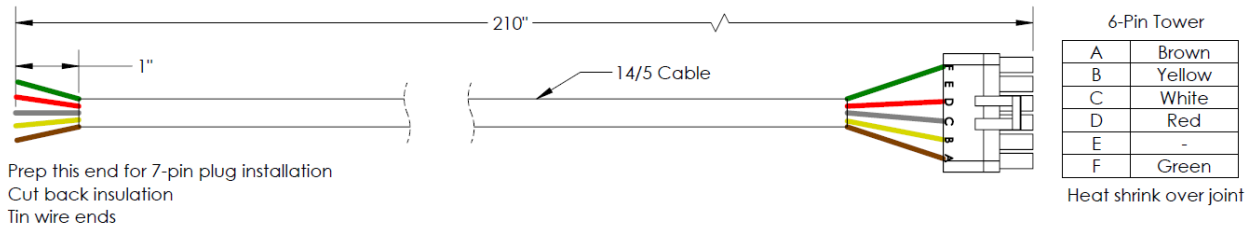

Wishbone Light Harness #32997

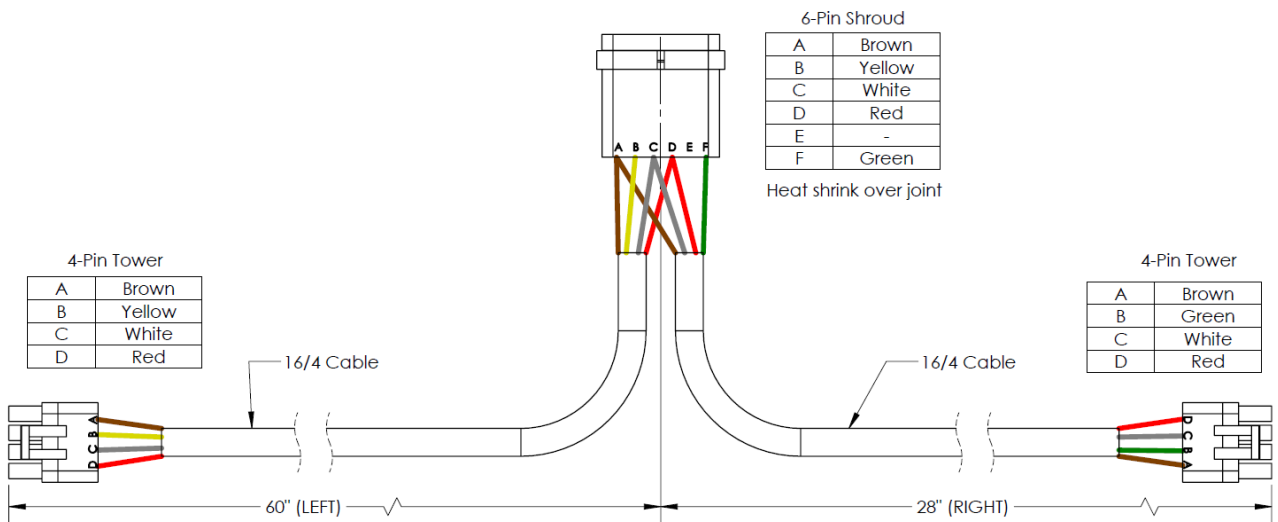

7-pin Light Plug #12177

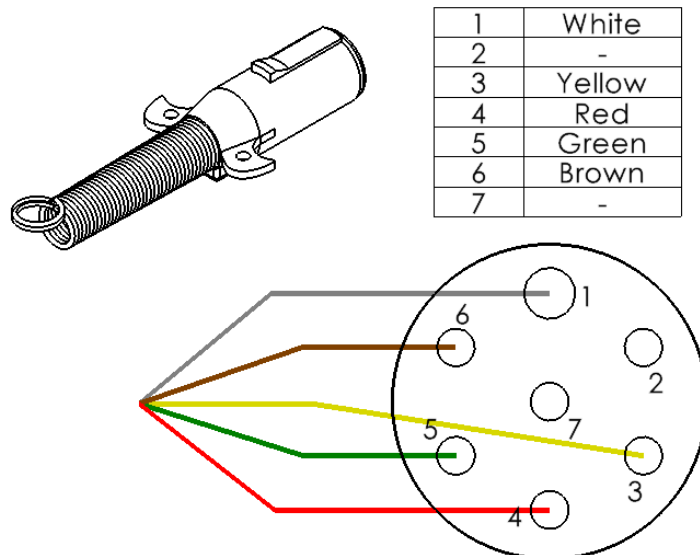



Rear Fork

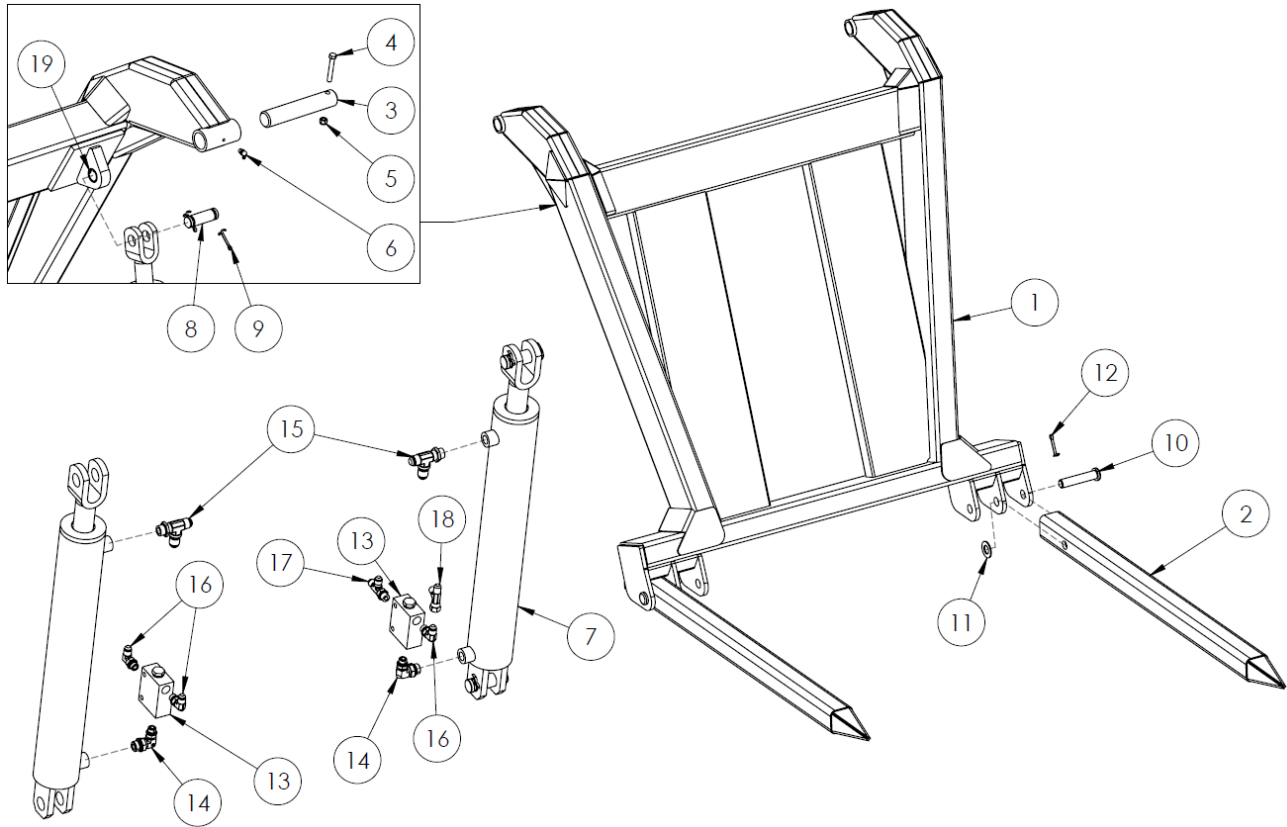

	Description	ID #	QTY		Description	ID #	QTY
1	Rear Fork Frame	33759	1	10	Tine Pin	10031	2
2	Fork Tine	22421	2	11	Washer, 1" Flat	14472	2
3	Fork Pivot Pin	22006	2	12	Cotter Pin, 1/4 x 2"	10580	2
4	Bolt, 3/8 x 2-1/2"	26307	2	13	Hydraulic Check Valve	19114	2
5	Nut, 3/8" Nylon Lock	10806	2	14	Hyd. Fitting, 8MB-6MB90	33739	2
6	Grease Zerk, 1/4" x 90°	16389	2	15	Hyd. Fitting, 8MBR-8MJT	22159	2
7	Hydraulic Cylinder, 3 x 18 x 1.5" <i>Seal Kit</i>	21717 20807	2	16	Hyd. Fitting, 6MB-6MJ90	10201	3
8	Cylinder Pin, 1 x 3-1/2"	10339	4	17	Hyd. Fitting, 6MBR-6MJT	23726	1
9	Cotter Pin, 3/16 x 1-1/2"	10072	8	18	Hyd. Fitting, 6FJXR-6MJT	15760	1
				19	Bushing Insert	23708	4



Three Bale Kit Option

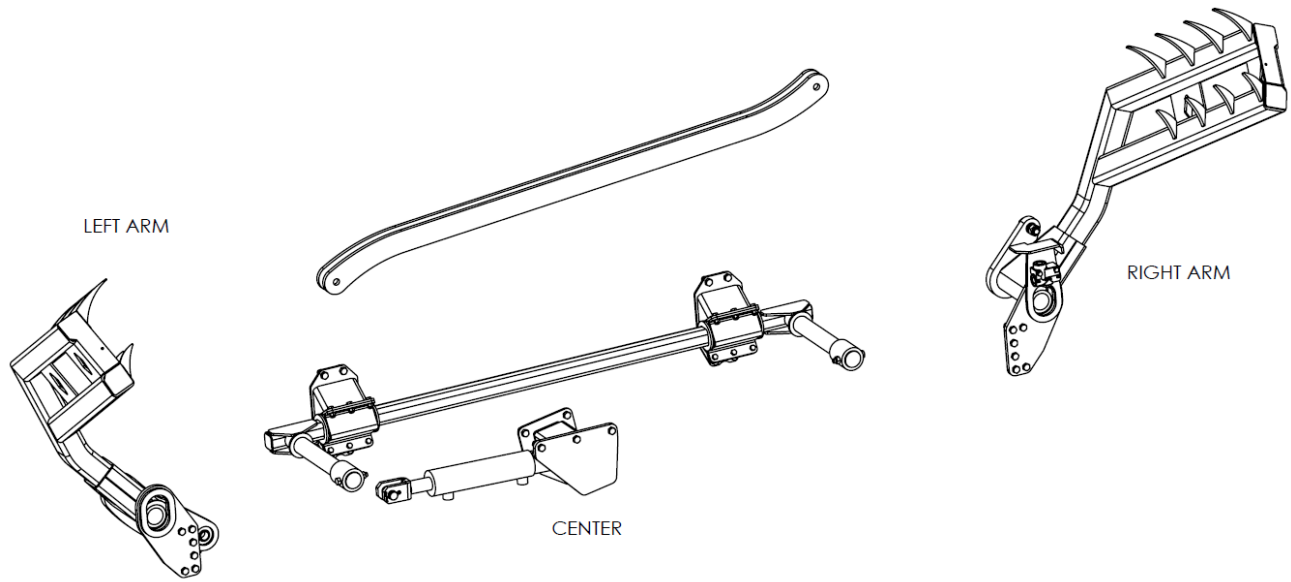

	Description	ID #	QTY		Description	ID #	QTY
1	Left Arm	33328	1	15	Cylinder Pin, 1 x 3-1/8"	10339	2
2	Right Arm	33329	1	16	Cotter Pin, 3/16 x 1-1/2"	10072	4
3	Torsion Bar Assembly <i>Individual parts not sold separately</i>	33926	1	17	Grease Zerk, 1/4"	16364	4
4	Torsion Bar Mount	NSS	2	18	Bushing, 1" OD x 3/4" ID x 1-1/16"	29063	2
5	Rear Support Left	33332	1	19	Rubber Torsion Bar	NSS	8
6	Rear Support Right	33333	1	20	Bolt, 3/4 x 3"	27451	2
7	Cylinder Base Mount	33334	1	21	Nut, 3/4" Stover Lock	11823	2
8	Cylinder Mount Tub Adaptor <i>5300 only</i>	33387	1	22	Bolt, 1/2 x 1-3/4" Fine Thread	32151	15
9	Timing Bar	33335	2	23	Nut, 1/2" Stover Lock Fine Thread	32153	15
10	Shaft Rear Bushing	33336	2	24	Bolt, 1/2 x 3-1/2"	10353	2
11	Torsion Clamp	NSS	2	25	Bolt, 1/2 x 1-1/4"	10240	9
12	Hydraulic Cylinder, 2-1/2" x 8" <i>Comes with pin (15) # Seal Kit</i>	30126 17609	1	26	Nut, 1/2" Stover Lock	20154	10
13	Depth Control Valve	30980	1	27	Bolt, 3/8 x 1"	13806	12
14	Press-in Bushing, 1"	23708	2	28	Nut, 3/8" Nylon Lock	10806	12
				29	Bolt, 5/16 x 2-1/2"	19115	2
				30	Nut, 5/16" Nylon Lock	11815	2



Three Bale Kit Left Arm

See reference table page 95

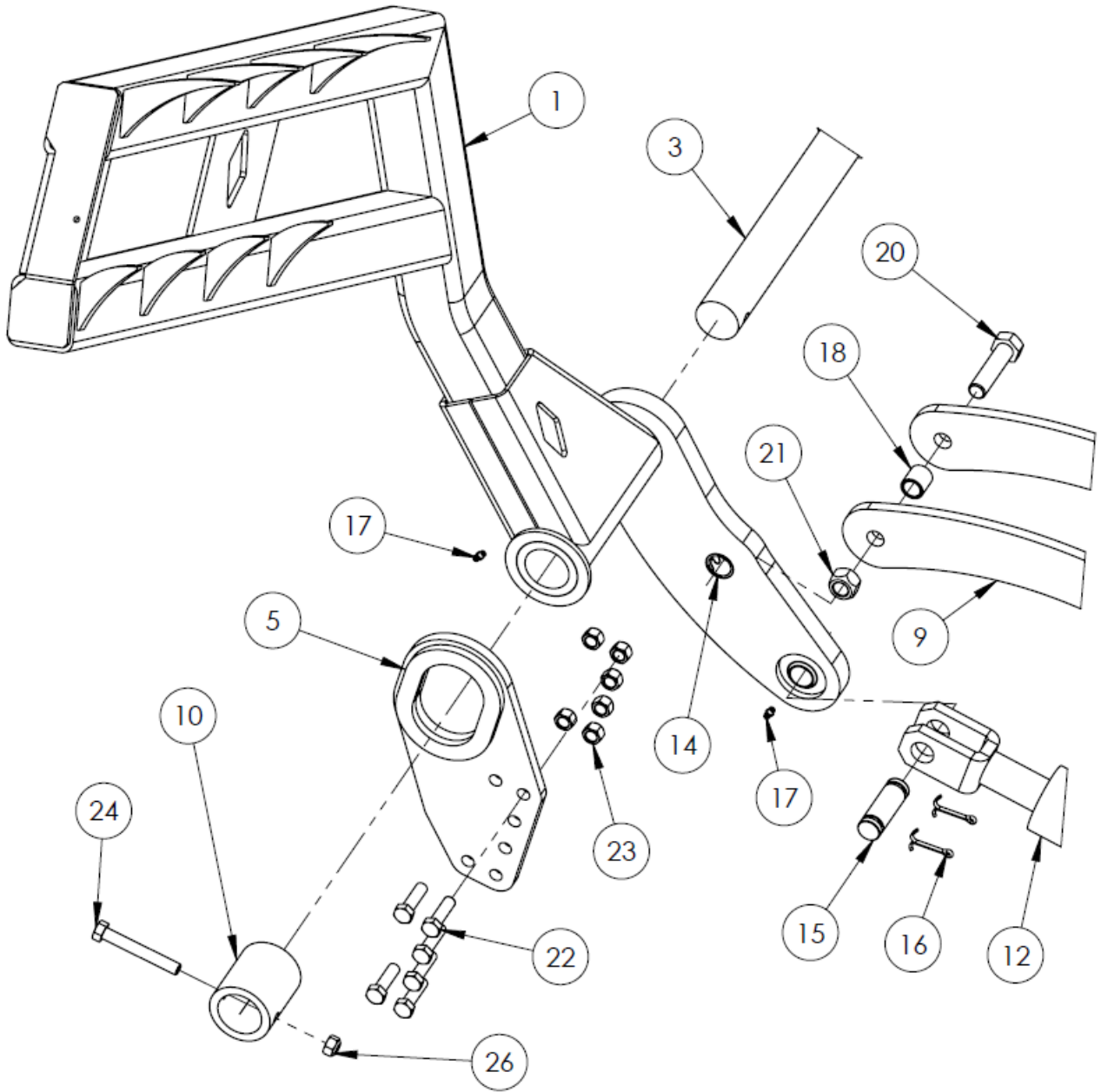



Three Bale Kit Right Arm

See reference table page 95

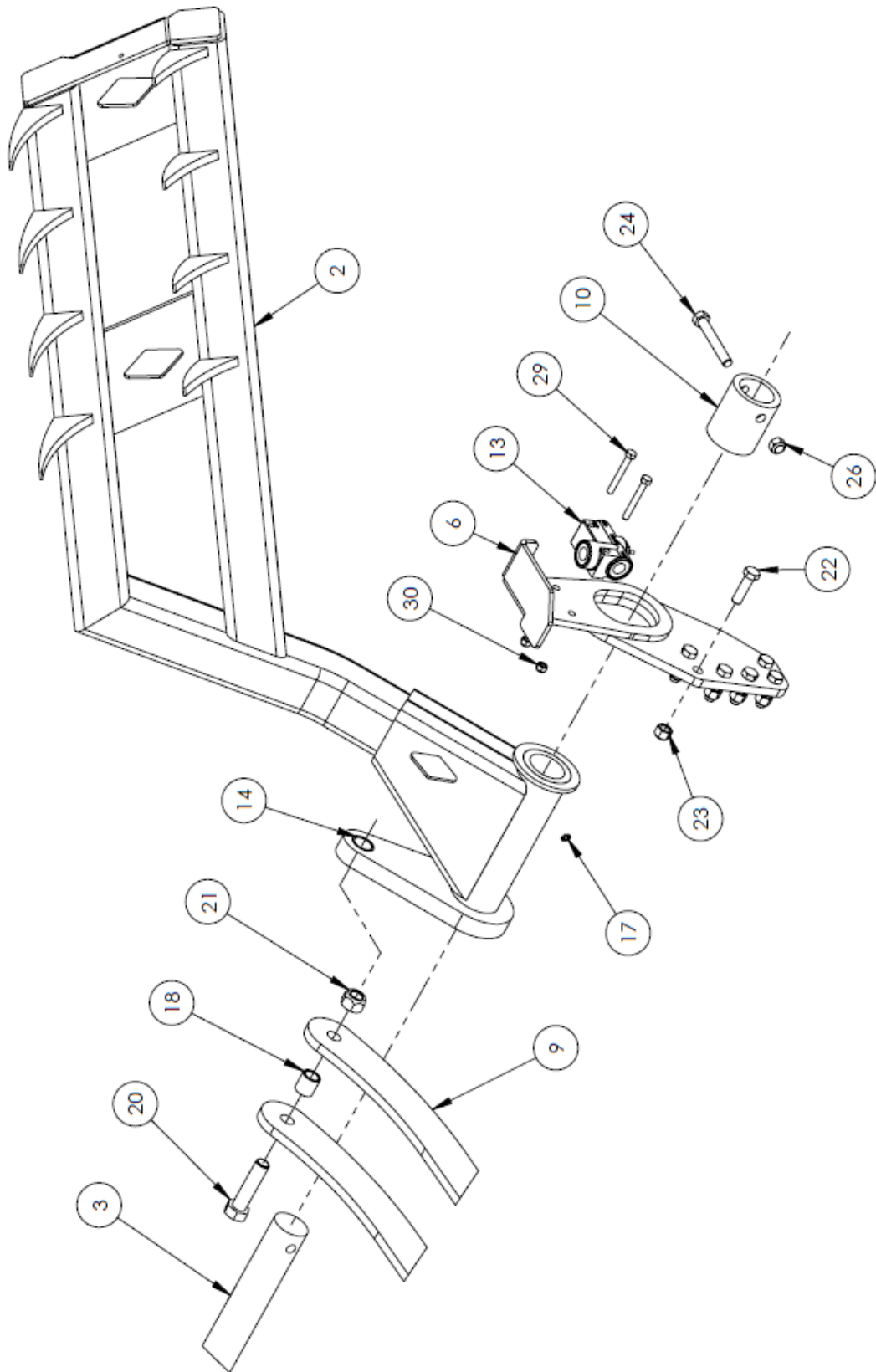



Three Bale Kit Center

See reference table page 95

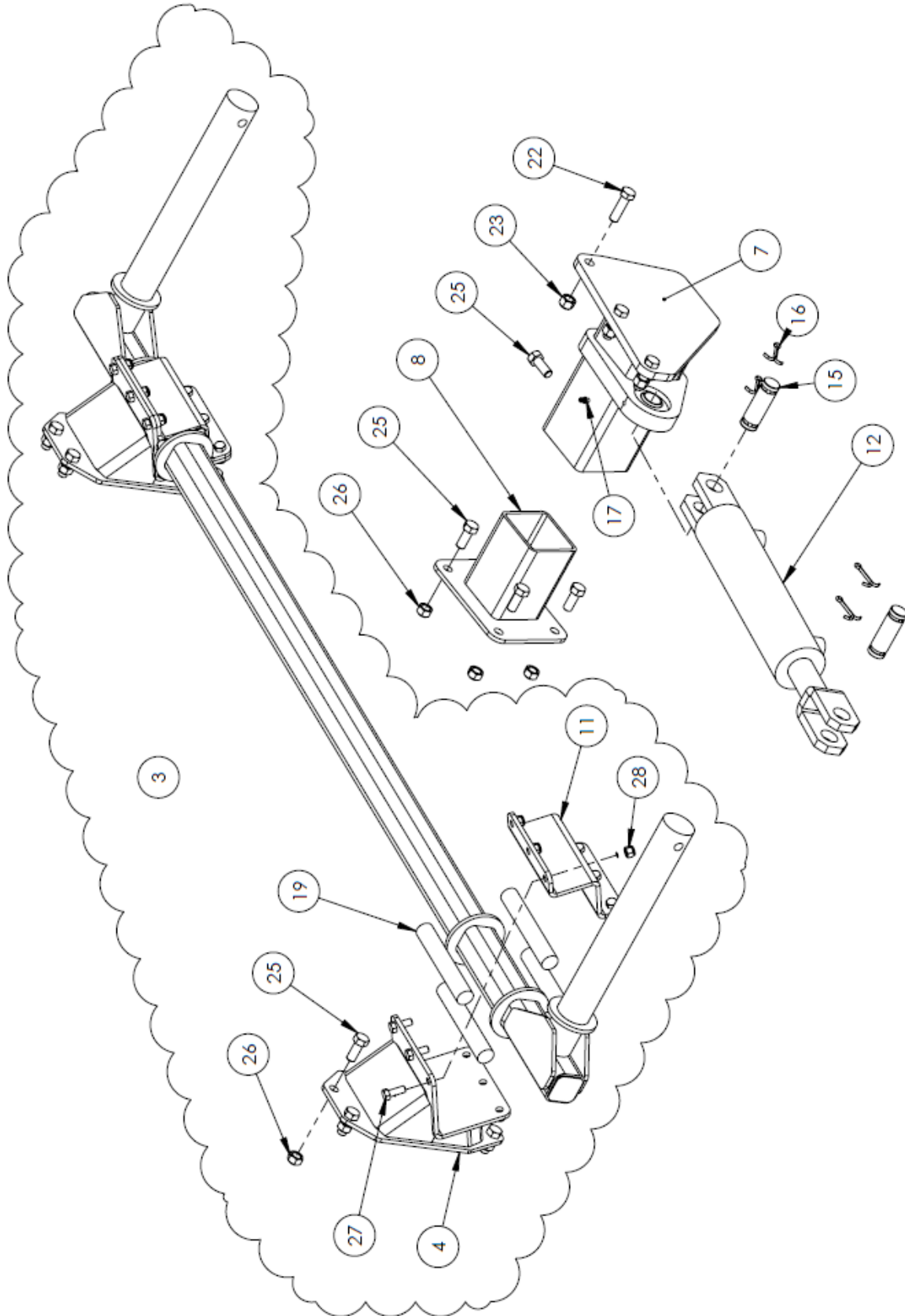



Back-up Camera Option

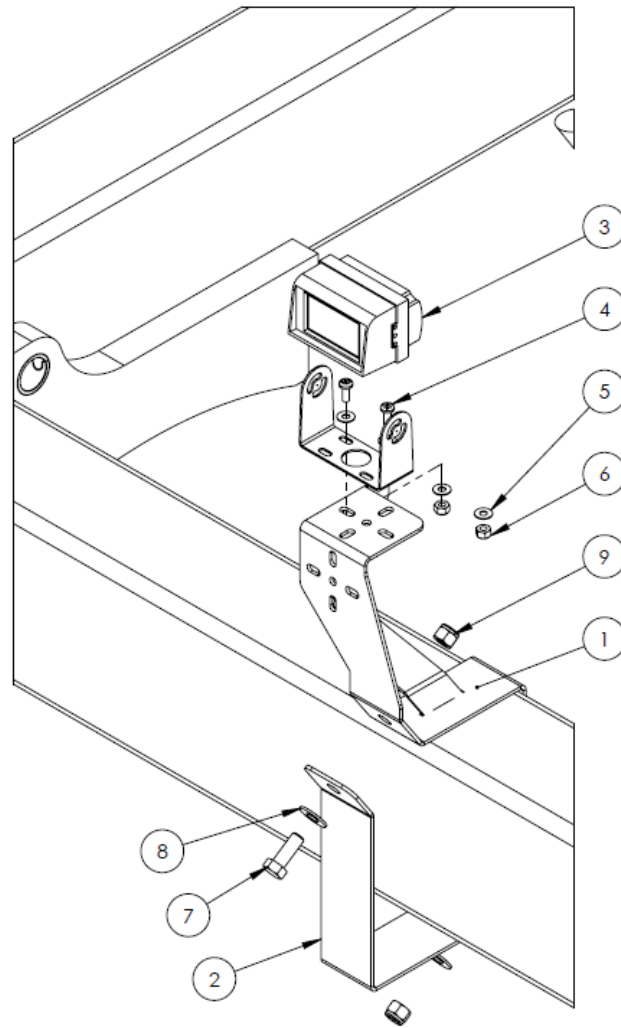

	Description	ID #	QTY		Description	ID #	QTY
	Back-up Camera Kit – STD	32619		5	Washer, #10 Flat	25600	4
	Back-up Camera Kit – PRO	32628		6	Nut, #10 Nylon Lock	31110	2
1	Camera Mounting Bracket	32618	1	7	Bolt, 3/8 x 1"	13806	2
2	Camera Mounting Strap	32617	1	8	Washer, 3/8" Flat	11667	4
3	Camera Package– STD	32640	1	9	Nut, 3/8" Nylon Lock	10806	2
	Camera Package– PRO	32639		10	Extension Cable, 15'	32645	1
4	Bolt, #10 x 1/2"	17035	2	11	Grommet, 5/16" ID x 1/4"	13179	2

NOTE: Camera package includes camera bracket, monitor, and harnesses. Individual parts NSS.



Decals



2



3



4

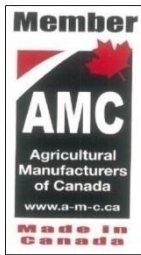

5



6



7



8

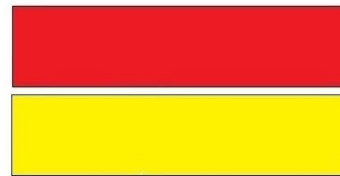

9

10

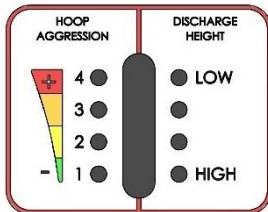

11

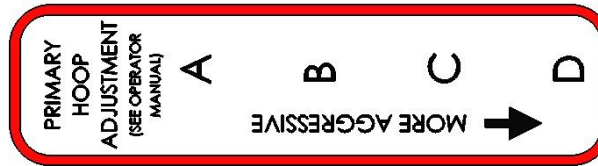

12



13



14



15

	Description	ID #	QTY		Description	ID #	QTY
1	"BALE KING"	32804	2	10	Amber Reflector	28384	4
	"7400"	32995		11	Hoop Adjustment Lower	32974	1
2	"DANGER", PTO	12219	2	12	Hoop Adjustment Top	32975	1
3	"DANGER", Discharge	12230	4	13	Speed Limit	33159	1
4	"DANGER", Stand Clear of Lift	12229	2	14	Rotor Access Door Warning	33379	1
5	AMC Member	12239	1	15	Hyd. Functions, 3-Remote	33380	1
6	FEMA Member	25347	1		Hyd. Functions, 2-Remote	33383	
7	Wheel Torque Reminder	28385	2		Hyd. Functions, 7400X 4-Remote	33382	
8	Deflector Safety Lock	22292	1		Hyd. Functions, 7400X 3-Remote	33381	
9	Red Reflector	28383	1				



HYDRAULIC SCHEMATICS

Hydraulic Components	102
Hydraulic Fittings	102
Hydraulic Hoses	103
Front Panel – Chain Motor	104
Front Panel – 7400 – 3 Remote.....	105
Front Panel – 7400 – 2 Remote.....	106
Front Panel – 7400X – 4 Remote.....	107
Front Panel – 7400X – 3 Remote.....	108
Front Panel – 7400X – 2 Remote.....	109
Rear Fork	110
Rear Fork & Three Bale Kit.....	111



Hydraulic Components

#	DESCRIPTION	PART #
AA	Hydraulic Motor * Seal Kit	28702 25891
BB	Hydraulic Cylinder, 1-1/2 x 6" * Seal Kit	21711 23738
CC	Hydraulic Cylinder, 3 x 18" * Seal Kit	21717 20807
DD	Hydraulic Cylinder, 2-1/2 x 8" * Seal Kit	30126 17609
EE	Diverter Valve * Double Stack Kit * Nut & O-Ring Kit * Magnet Kit	11743 12895 17977 11798
FF	Line Lock Valve	19114
GG	Depth Control Valve	30980
HH	Check Valve	12171
JJ	Pioneer Tip	17379
KK	Flow Control Valve	10455

NOTE: Quantities vary depending on machine set-up. Order as required.

Hydraulic Fittings

	Description	ID #		Description	ID #
A	10MB-8MJ45	23844	L	8MB-6MJ	11740
B	10MB-8FJX90	33744	M	8MB Plug	31013
C	10MB-8MJ90	12169	N	6MJBH	11767
D	10MB-6MJ45	22722	O	6MB-6MJ90	10201
E	10MB-6MJ	11739	P	6MB-6MJ	10162
F	8MB-6MB90	33739	Q	6MB-6MJ Orifice (1/32")	17436
G	8MBR-8MJT	22159	R	6MBR-6MJT	23726
H	8FJXR-8MJT	11768	S	6MBL-6MJT	27678
I	8MB-6MJ90	10200	T	6FJXR-6MJT	15760
J	8MB-6MJ45	11725	U	6FJ Cap	26474
K	8MB-8MJ	10561			

NOTE: Quantities vary depending on machine set-up. Order as required.



Hydraulic Hoses

#	DIAM.	OVERALL LENGTH	ENDS	
1	1/2"	113"	8MB	8FJX
2	1/2"	15.5"	8FJX	8FJX
3	1/2"	11"	8FJX	8FJX
4	3/8"	122"	8MB	6FJX90
5	3/8"	120"	8MB	6FJX90
6	3/8"	112"	8MB	6FJX
7	3/8"	80"	6FJX	6FJX
8	3/8"	58"	6FJX	6FJX
9	3/8"	49"	6FJX	6FJX90
10	3/8"	37"	6FJX	6FJX90
11	3/8"	29-1/2"	8FJX	8FJX
12	3/8"	29"	6FJX	6FJX90
13	3/8"	28"	6FJX	6FJX90
14	3/8"	20"	6FJX	6FJX
15	3/8"	20"	6FJX	6FJX90
16	3/8"	16"	6FJX	8FJX
17	3/8"	14-1/4"	6FJX	8FJX
18	1/4"	147"	8MB	6FJX90 (LONG)
19	1/4"	20"	6FJX	6FJX90
20	1/4"	18"	6FJX	6FJX90
21	1/4"	24"	6FJX	6FJX90 (LONG)

NOTE: Quantities vary based on machine set-up. Hoses are not available for sale from Bridgeview.
Use the information above to have replacement hoses made up locally.



Front Panel – Chain Motor

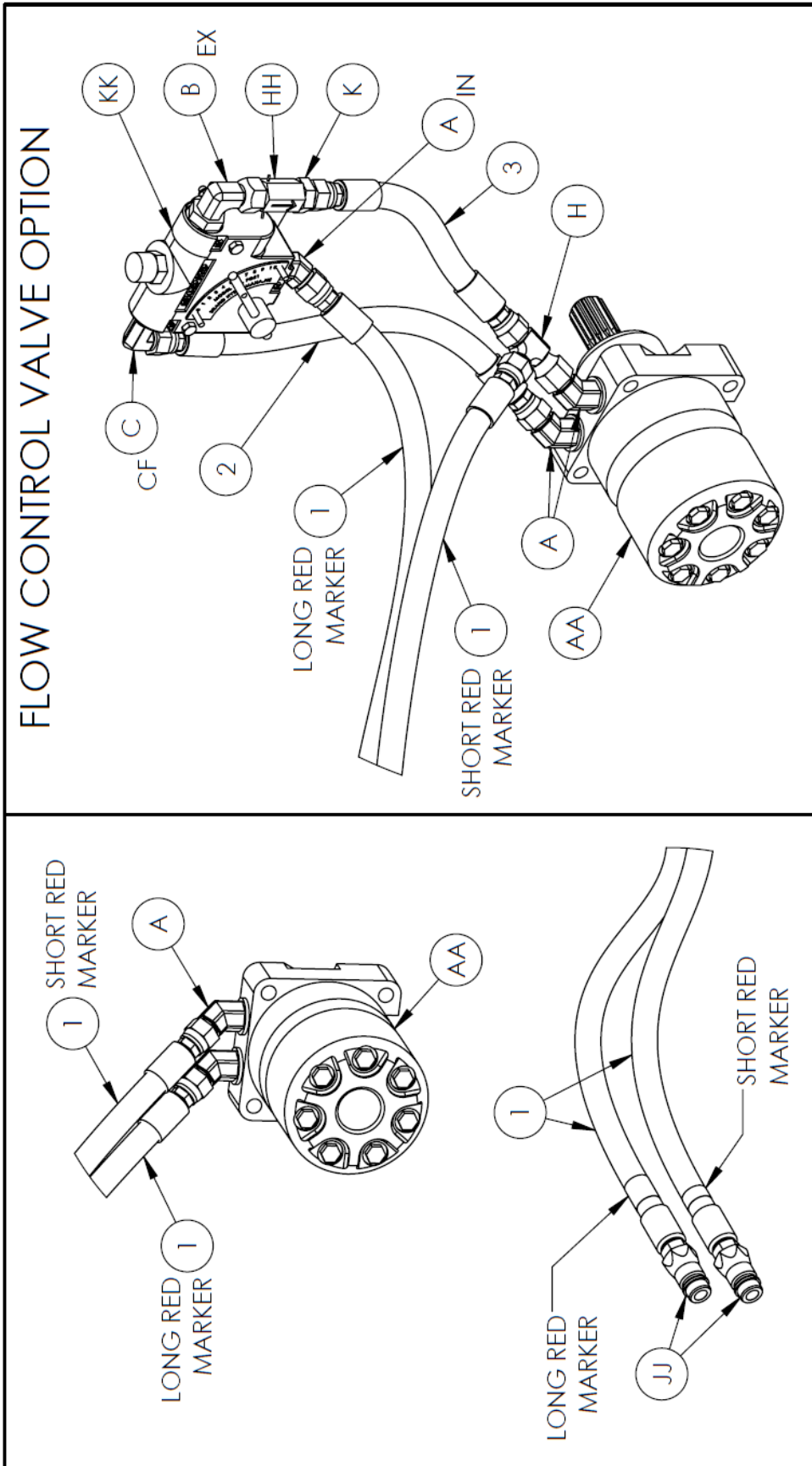



Front Panel – 7400 – 3 Remote

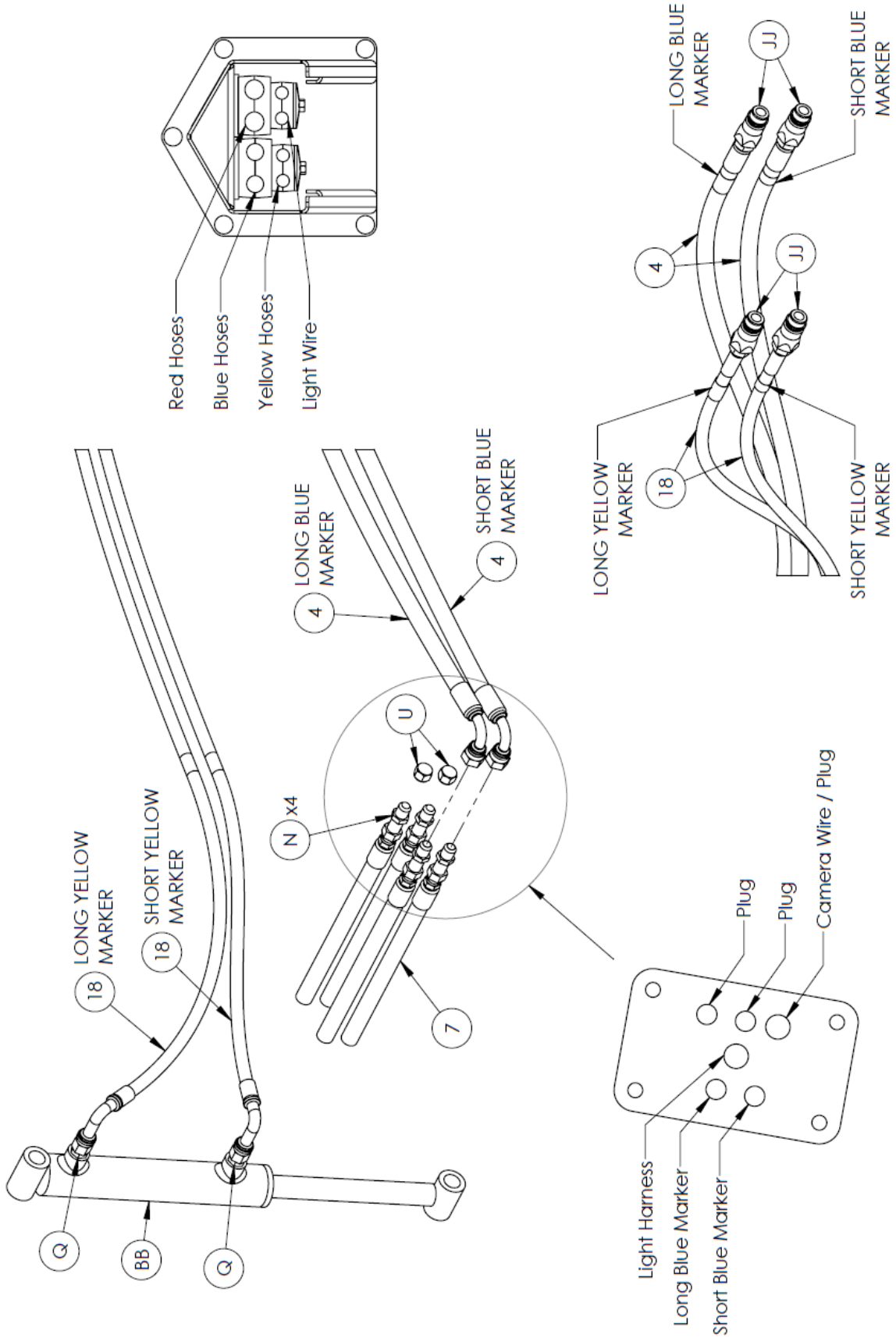



Front Panel – 7400 – 2 Remote

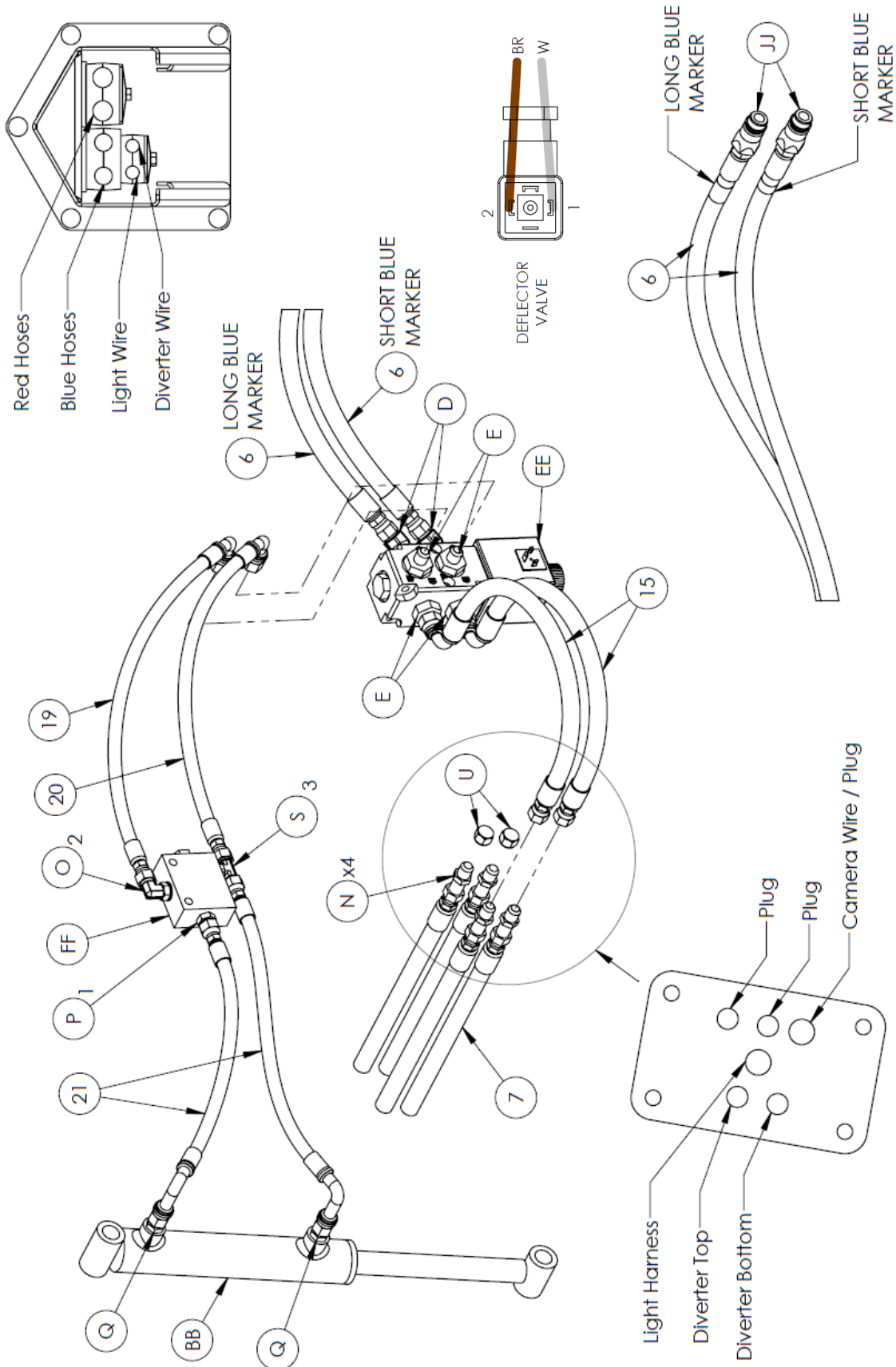



Front Panel – 7400X – 3 Remote

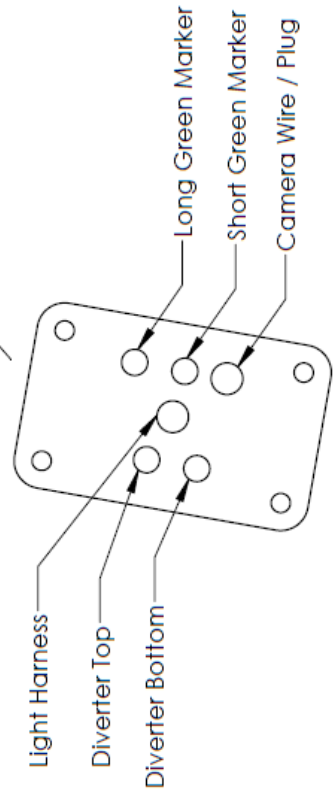
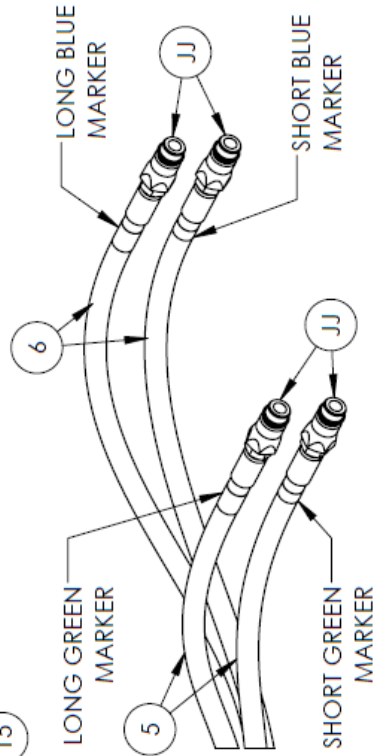
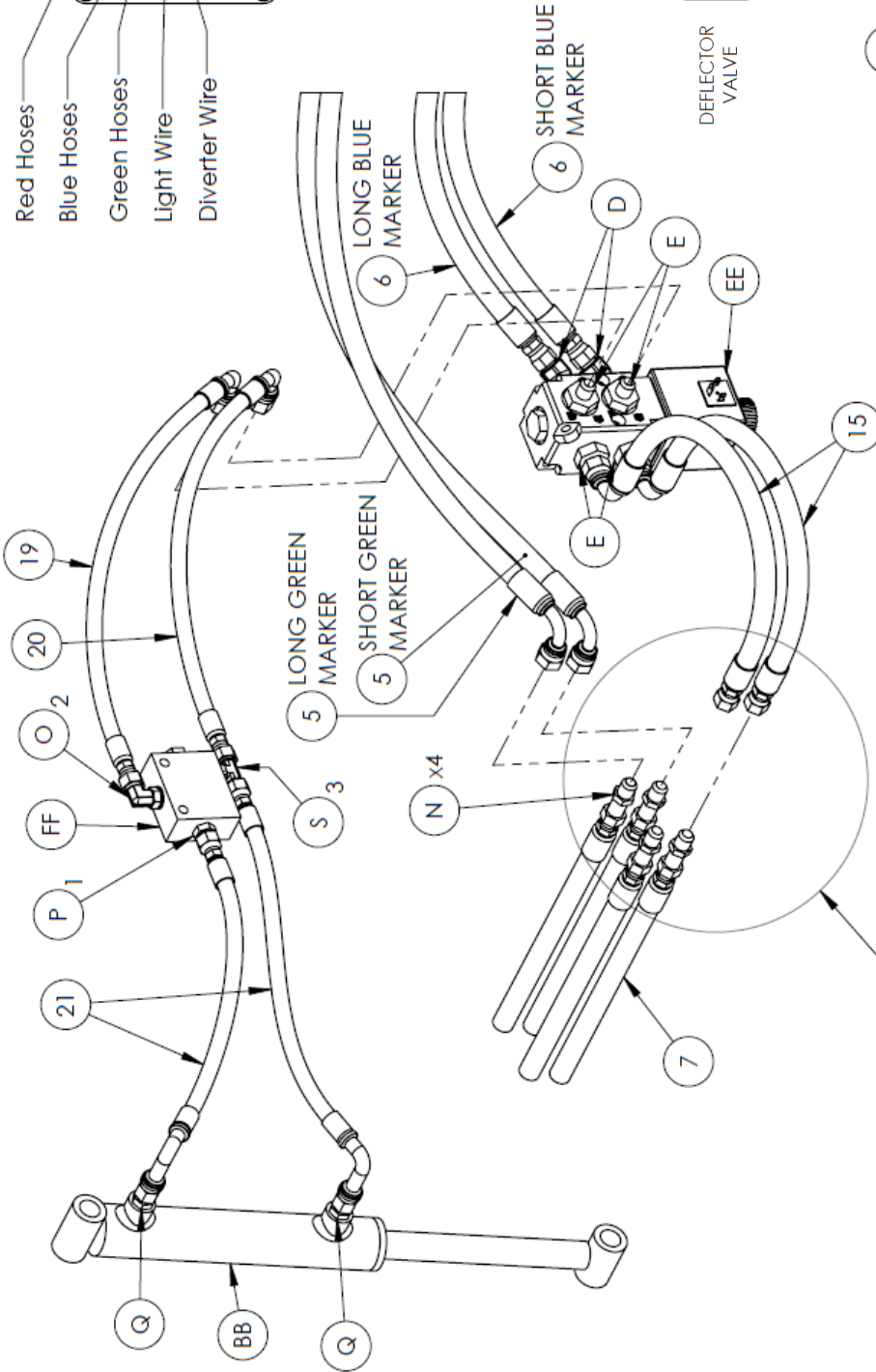
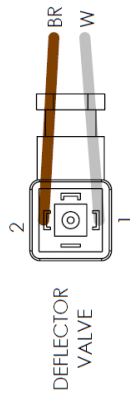
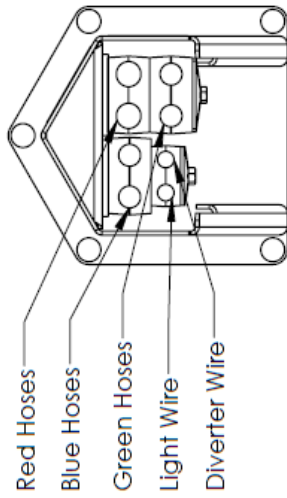



Front Panel – 7400X – 2 Remote

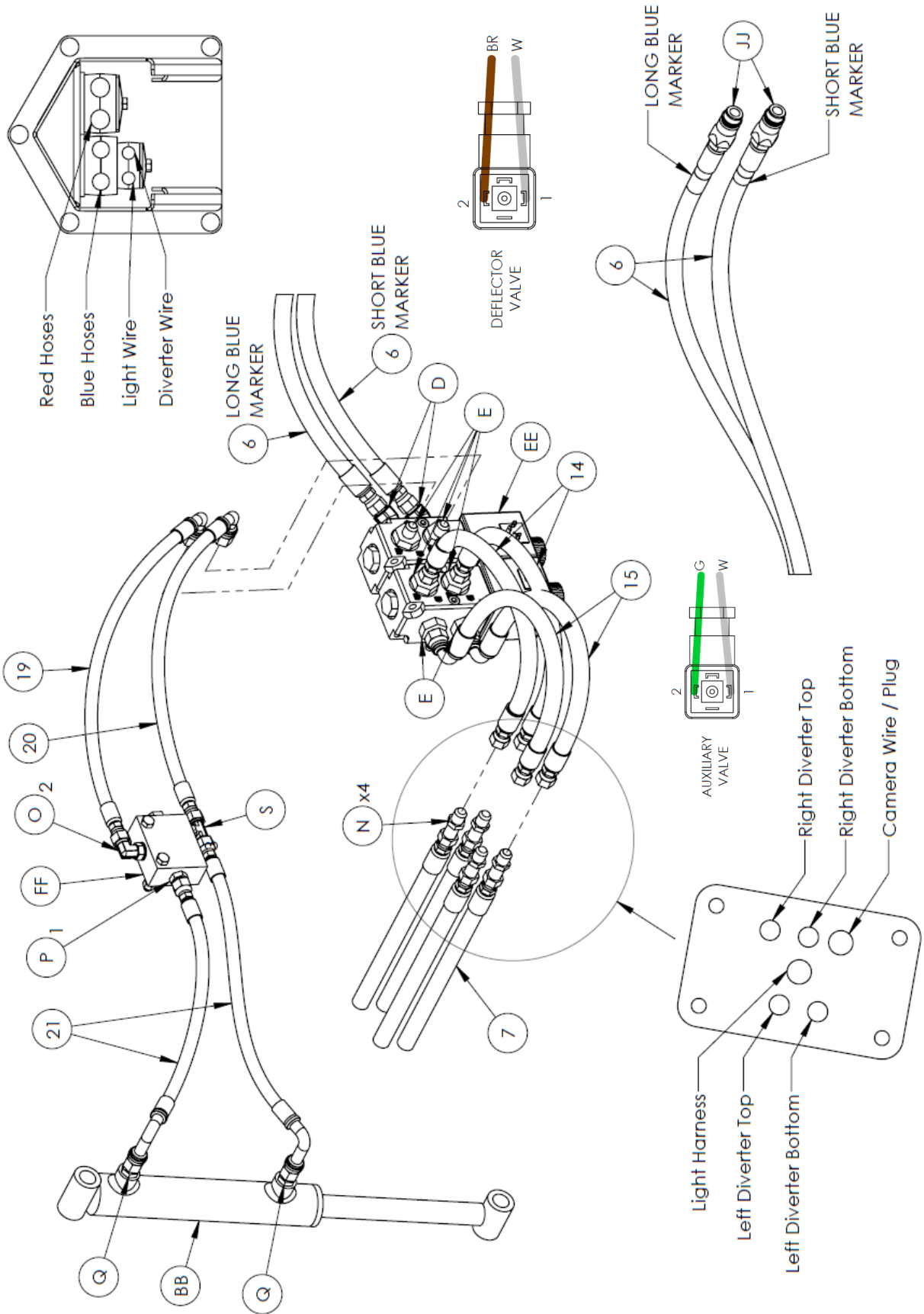



Rear Fork

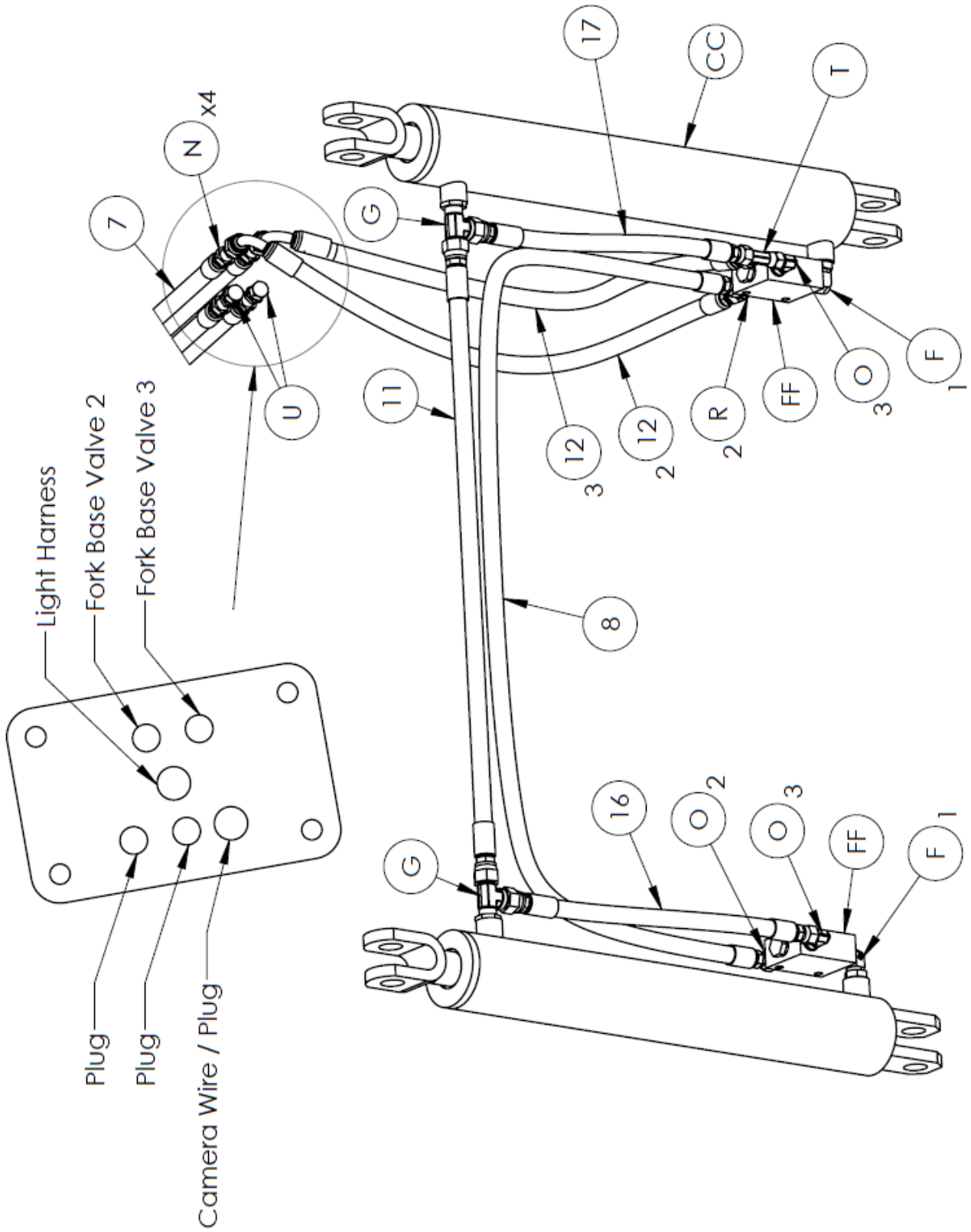



Rear Fork & Three Bale Kit

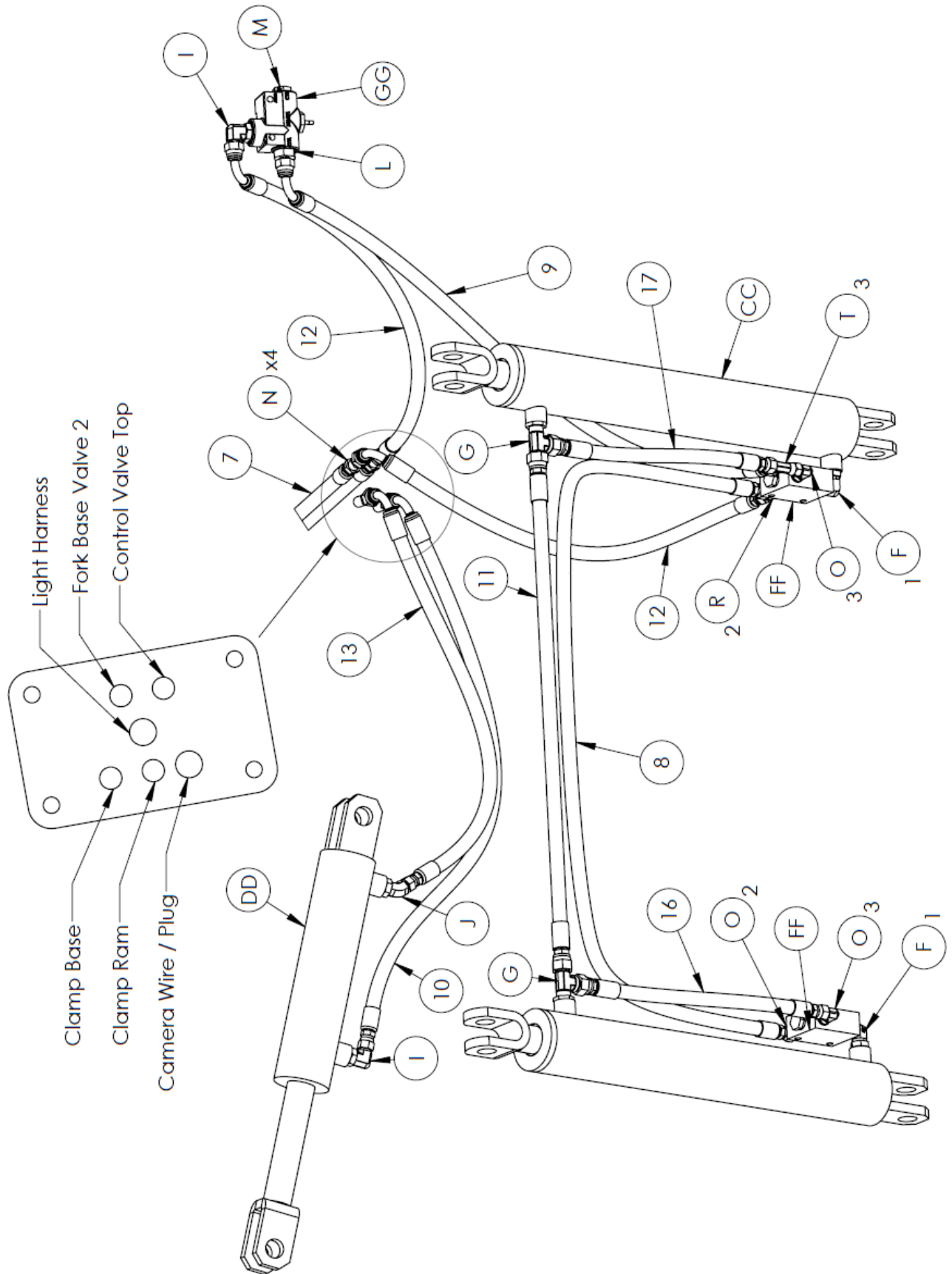



NOTES

A series of horizontal dashed lines spanning the width of the page, intended for handwritten notes.