

PULLDOZER

1220A

Scraper Pan

Operator's & Assembly Manual

Last Updated: October 24, 2023

Bridgeview Manufacturing Inc.
P.O. Box 4
Gerald, Saskatchewan, Canada
S0A 1B0
Phone: 1-306-745-2711
Fax: 1-306-745-3364
Email: bmi@sasktel.net
www.bridgeviewmanufacturing.com

Your Authorized Dealer
Your Serial Number

The serial number is located on the front left side corner of the bowl.

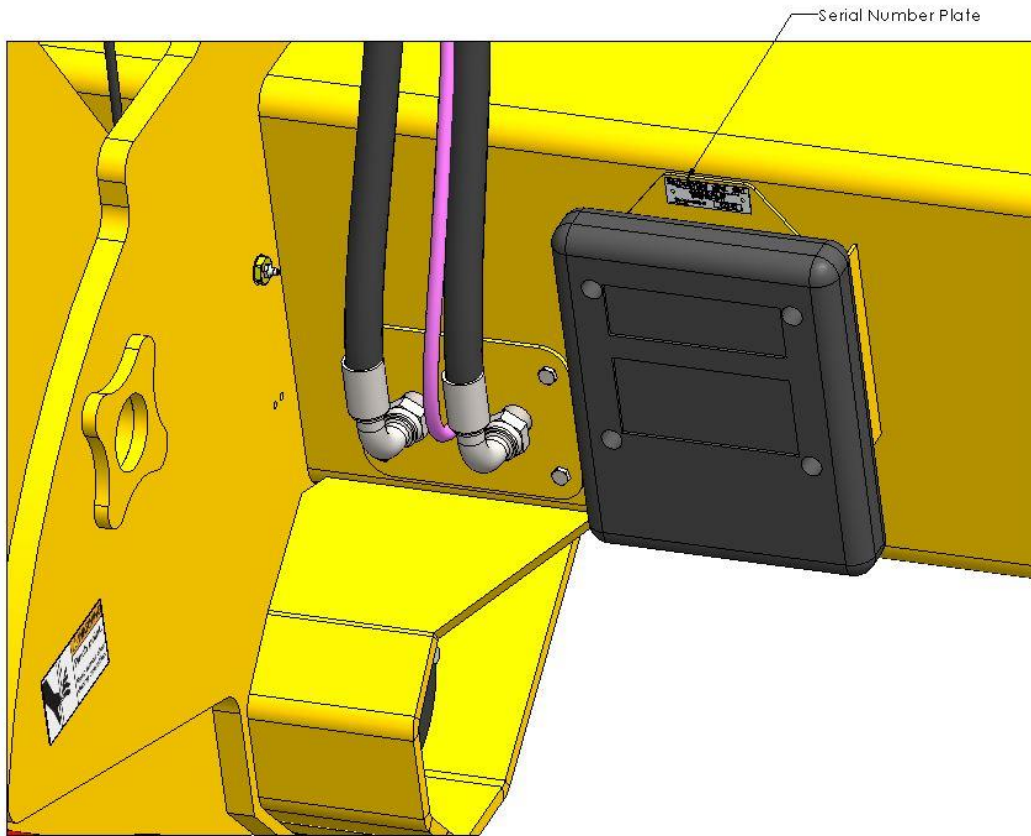

	<p>⚠ WARNING</p> <p>Failure to read and understand operator's manual & all safety signs could result in serious injury. Manual must remain with machine.</p>
---	--

TABLE OF CONTENTS

1	INTRODUCTION.....	4
1.1	Safety Precautions.....	5
1.1.1	Recognize Safety Information.....	6
1.1.2	Power Requirements:.....	2
1.1.3	Hydraulic Systems:.....	3
1.2	Transportation.....	4
1.2.1	Dimensions.....	4
1.2.2	Lights and Marking.....	5
1.2.3	Safety Locks.....	6
2	OPERATION AND FEATURES.....	7
2.1	Operating Scraper unit.....	7
2.1.1	Operating Guidelines.....	7
2.1.2	Loading the Scraper.....	7
2.2	Preparing the Tractor.....	8
2.2.1	Loading Specifications Table.....	8
2.3	Attaching Scraper to Tractor.....	9
2.4	Disconnecting the Scraper from Tractor.....	10
2.5	Top Loading.....	11
2.6	Push Loading.....	11
2.7	Overload Conditions.....	11
2.7.1	Material Density Table.....	12
2.8	Hydraulics.....	13
2.9	Adjustments.....	13
2.9.1	Implement Swivel Hitch.....	13
2.9.2	Front Hose Holder.....	14
2.9.3	Cutting Depth Indicator.....	15
2.9.4	Apron Height Indicator.....	15
2.9.5	Sequence Apron and Ejector Valve.....	16
2.9.6	Ejector Clearance.....	19
2.10	Optional Lead Scraper Kit.....	20
2.10.1	Lead Scraper Parts Book.....	21
2.10.2	Lead Scraper Hydraulic Schematic.....	2
2.10.3	Lead Scraper Electrical Schematic.....	4
2.11	Optional GPS Tower Kit.....	5
2.12	Optional GPS Tower and Height Indicators Kit.....	2
2.13	Optional Brake Kit.....	3
2.13.1	Hook-Up/Operation.....	3
2.13.1	Bleeding Hydraulics.....	3
2.13.2	Centering Rotor on Brake Assembly.....	4

2.13.3 Brake Assembly	5
2.13.4 Brake Hydraulic Schematic.....	2
2.14 Optional Tractor Brake Kit.....	4
2.14.1 Hook-Up/Operation	4
2.14.2 Setting Pressure Valve/Brake Distance.....	5
2.14.3 Tractor Brake Assembly	6
2.14.4 Tractor Brake Hydraulic Schematic.....	2
2.15 Specifications.....	3
3. MAINTENANCE & LUBRICATION.....	4
3.1 Wheel and Tires	4
3.2 Greasing	5
3.3 Cutting Edge Wear.....	6
3.4 UHMW Plate/Bar Wear	7
3.5 Replaceable Bushings.....	8
4 PARTS BOOK.....	2
4.1 Swivel Hitch Assembly	3
4.2 Main Hitch Assembly	2
4.3 Bowl Assembly	2
4.3.1 Bowl-Hitch Assembly	3
4.3.2 Front Bowl Components (S/N PD1268 & Down).....	2
4.3.3 Front Bowl Components (S/N PD1269 & Up).....	2
4.3.4 Lift Cylinder Safety Lock	2
4.3.5 Tube Cover Assembly (S/N PD1268 & Down)	2
4.3.6 Tube Cover Assembly (S/N PD1269 & Up)	2
4.3.7 Cutting Edges	2
4.3.8 Rear Components Assembly (S/N PD1268 & Down).....	2
4.3.9 Rear Components Assembly (S/N PD1269 & Up).....	2
4.3.10 Wheel Assembly.....	2
4.3.11 Hub and Spindle Assembly.....	2
4.4 Ejector Assembly.....	2
4.5 Apron Assembly (S/N PD1268 & Down)	2
4.6 Apron Assembly (S/N PD1269 & Up)	2
4.7 Hydraulic Cylinders Assembly.....	2
4.8 Decals	3
4.9 Hydraulic Components	2
4.8.1 Hydraulic Schematic	2
4.10 Electrical Components.....	7
4.9.1 Light Wiring Schematic.....	7
5. Bolt Torque Values.....	9
6. Troubleshooting.....	11
NOTES.....	13

1 INTRODUCTION

Thank you for purchasing your new **Pulldozer 1220A** from Bridgeview Manufacturing. With the proper operation and service, as outlined in this manual, the Pulldozer will provide you with years of trouble-free operation.

The **Pulldozer 1220A** is a 20-yard scraper, specially suited for moving material fast with an agricultural scraper equipped tractor. An optional Lead Kit is available so you are able to pull two scrapers in a train thus moving twice as much dirt in the same amount of time. A lead scraper is the scraper that is being pulled behind the tractor and the pup scraper is the scraper that is being pulled by the lead scraper See 2.10 Optional Lead Scraper Kit for illustration. An optional GPS Tower is available, for more accurate depth control. An optional GPS Tower and Height Indicators Kit is available to be installed on the pup scraper to provide accurate cutting-edge depth and apron height control. A cutting depth indicator comes standard to provide accurate depth control. An apron depth indicator comes standard to provide accurate apron control. The values on the decal indicate inches. A standard hydraulic accumulator is installed on the machine to reduce the shock load on the tractor and provide a much smoother ride. A sequencing valve comes standard to reduce the amount of tractor remotes needed to operate the **Pulldozer 1220A**.

This is a complete safety, operation, and parts manual for the Pulldozer. The manual covers in detail how to use your new machine safely and effectively. The procedures outlined in this manual should be followed to ensure safe operation and longevity of your machine. The parts and assembly manual covers all parts you may need to order in case of accident or breakdown and how to install them. Please read completely through this manual before beginning operation of your new machine.

1.1 Safety Precautions

The following safety precautions **MUST** be followed to ensure the safe operation of the **Pulldozer 1220A**.

- **Tow at speeds not exceeding 31 miles/hour (50 km/h) when unloaded.** Slow down for hills, curves, rough area, and in advance of braking to prevent loss of control and possible injury or death.
- **Tow at speeds not exceeding 10 miles/hour (16 km/h) when loaded.** Slow down for hills, curves, rough area, and in advance of braking to prevent loss of control and possible injury or death.
- Read and follow the **Highway Transport** section before towing on public roads.
- **Always** turn off tractor, ensure parking brake is applied before leaving the operating platform, and remove key when working on machine
- **Always** leave scraper bowl on the ground when not operating.
- **Always** leave apron and ejector hydraulic cylinders, when not operating, in the de-stroked position.
- **Stand clear** of the Pulldozer 1220A while in operation.
- **Do not** stand near inside the Pulldozer 1220A during opening or closing.
- **Beware** of pinch points at all articulating joints.
- **Support Raised Equipment** when working on machine
- **Be Aware** of loading material density
- **Do Not** over load scraper and tractor design limits

1.1.1 Recognize Safety Information

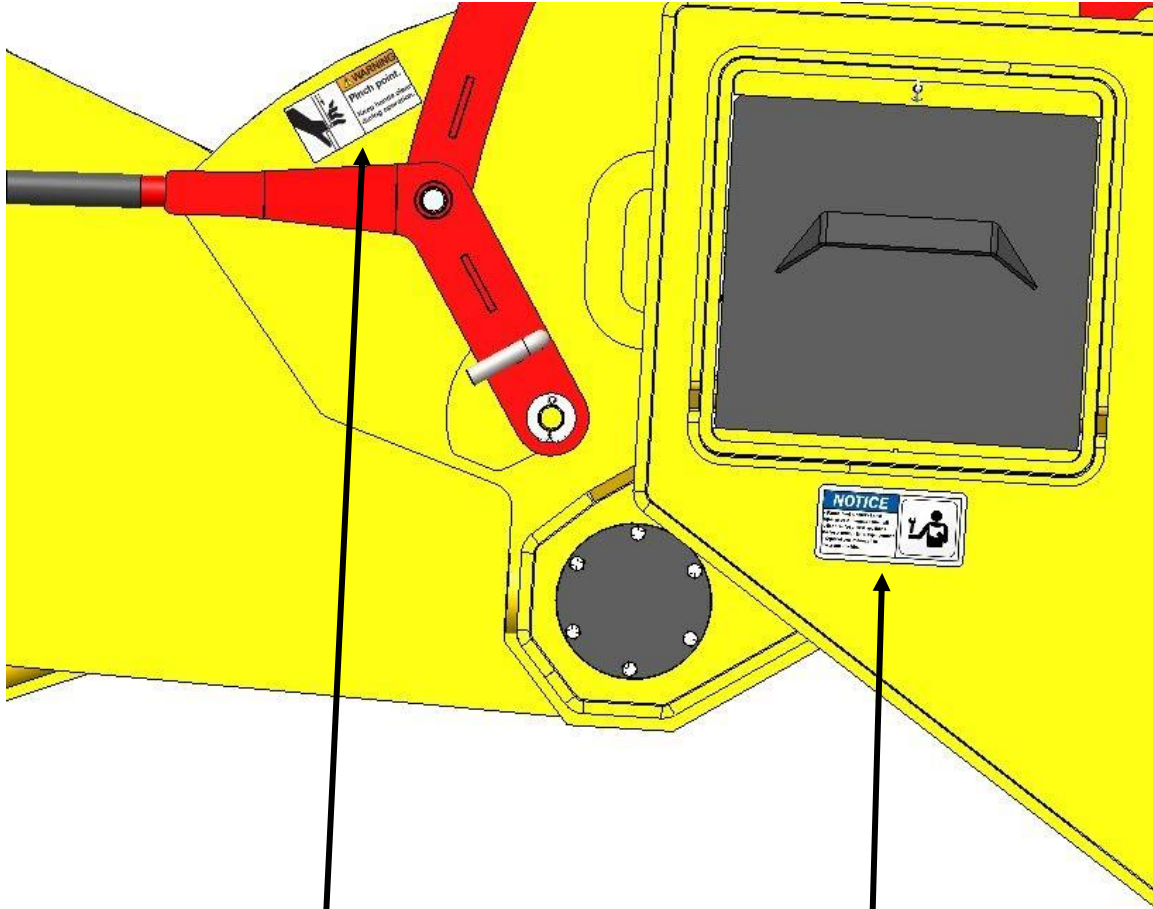

This is a pinch point symbol.
When you see this symbol on your machine or in this manual, be aware of the potential for personal injury.

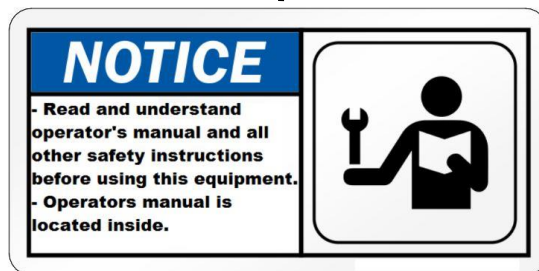

This is an operator's manual notice. Make sure to read and understand all instructions about the machine before operating.

1.1.2 Power Requirements:

The Pulldozer is designed to utilize the pulling power of a large four-wheel-drive tractor. The following table shows the recommended drawbar horsepower required to pull a Pulldozer 1220A. Pulling with too large a tractor risks damaging the machine, while too small a tractor risks overloading and damaging the tractor.

	Horsepower
20 Yard Scraper	400 - 600 HP

Call Before You Dig:

Every time you dig in the ground, wherever it may be, **THERE IS DANGER BELOW!** You run the risk of loss of life or damage to property if you hit any of the many buried cables, conduits, gas or oil pipelines and/or other underground facilities that serve our cities, towns, and rural areas.

Contact the nearest **ONECALL** (**Call Before You Dig**) with optimal diligence towards preventing damage to underground infra



Canada		
Province	Number	Website
British Columbia	1.800.474.6886	http://www.bconecall.bc.ca/
Alberta	1.800.242.3447	http://www.alberta1call.com/
Saskatchewan	1.866.828.4888	http://www.sask1stcall.com/
Manitoba	1.800.827.5094	www.callb4udig.mb.ca/
Ontario	1.800.400.2255	http://www.on1call.com/
Quebec	1.800.663.9228	http://www.info-ex.com/
United States		
All states	811	http://www.call811.com/
TransCanada Pipelines		
Canada	1.888.982.7222	
United States	1.800.447.8066	

1.1.3 Hydraulic Systems:

Hydraulic systems store considerable energy. They are used to:

- lift and change the position of attachments
- operate hydraulic motors
- assist in steering and braking

Leaks from hydraulic systems are a serious hazard because of the high pressure and temperature of the fluid contained in the system. Even fine jets of hydraulic fluid can burn or pierce skin and tissue. Workers should:

- Never inspect hydraulic hoses with bare hands;
- Wear long sleeves, heavy gloves and safety glasses when checking for leaks;
- Follow the instructions (blade to be on the ground and no pressure in hydraulic lines during maintenance) because the specific procedures for servicing these systems are very important for one's safety.

Where appropriate, a properly qualified and certified mechanic should perform repairs and maintenance.

Work should not be performed under raised hydraulic equipment.

If air has been allowed to enter hydraulic hoses or cylinders, bleed hydraulic system by cycling all hydraulic circuits several times before use. If there is a failure in the hydraulic system, unsupported raised equipment could suddenly lower, causing serious personal injury or death.

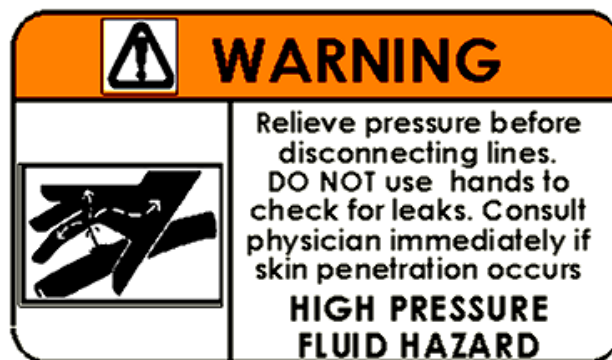

1.2 Transportation

When transporting the Pulldozer 1220A on public roads there are a number of safety precautions that must be taken to ensure safety to everyone on the road.

1.2.1 Dimensions

	Pulldozer 1220A
Transport Width	12'
Transport Height	12'
Transport Length	32' – 9"
Transport Weight (Gross)	28,000 lbs.
Transport Weight (Tongue)	7,200 lbs.

Ensure that road restrictions do not prohibit these dimensions, and that the towing vehicle and hitch are properly rated for the weight (both gross and tongue).

DO NOT EXCEED 31 mph (50 km/h) DURING TRANSPORT.

1.2.2 Lights and Marking

The Pulldozer 1220A comes standard with a light kit for better visibility. The lights can be plugged into the standard 7-pin round trailer plug on a tractor. The lights function as flashing amber lights, with solid red tail lights. Ensure that they are functioning properly before towing.

Ensure that the SMV (Slow Moving Vehicle) sign is in place and visible.

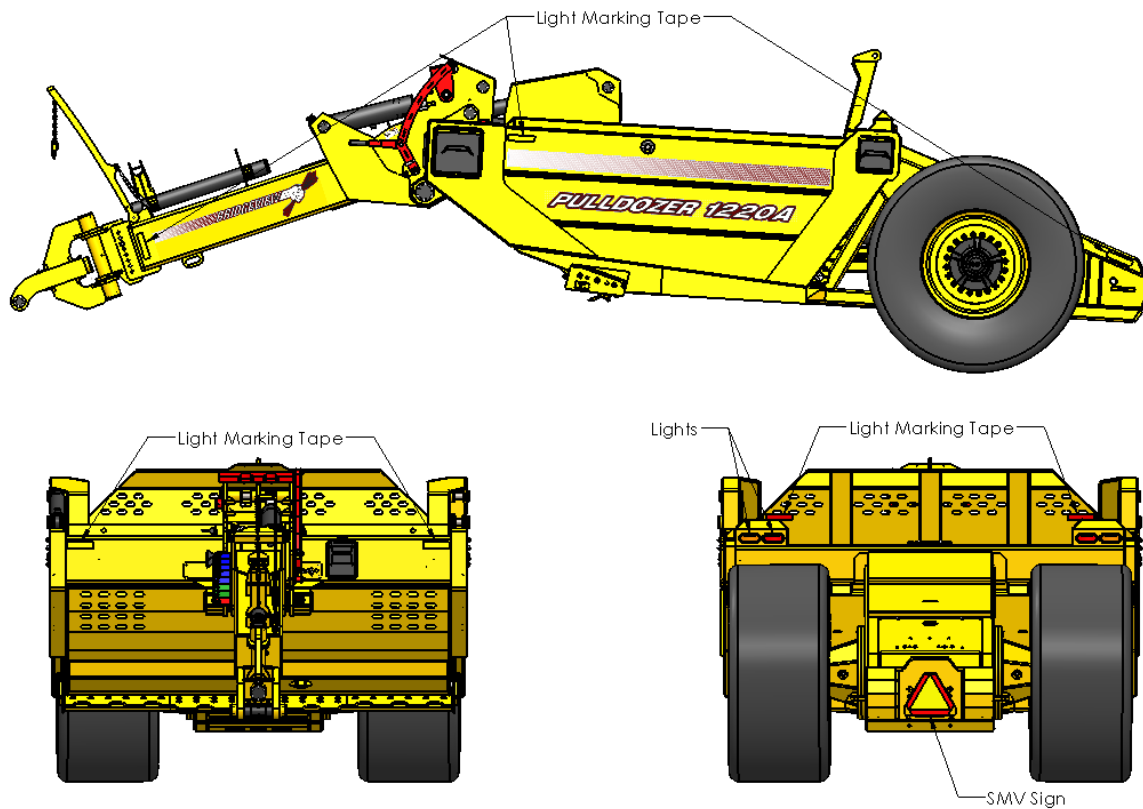

1.2.3 Safety Locks

Ensure that all the safety locks and pins are ON in the right position when working on machine. This will prevent injury to personal working on the machine.

- Apron safety latch – swing when apron hydraulic cylinders are fully stroked

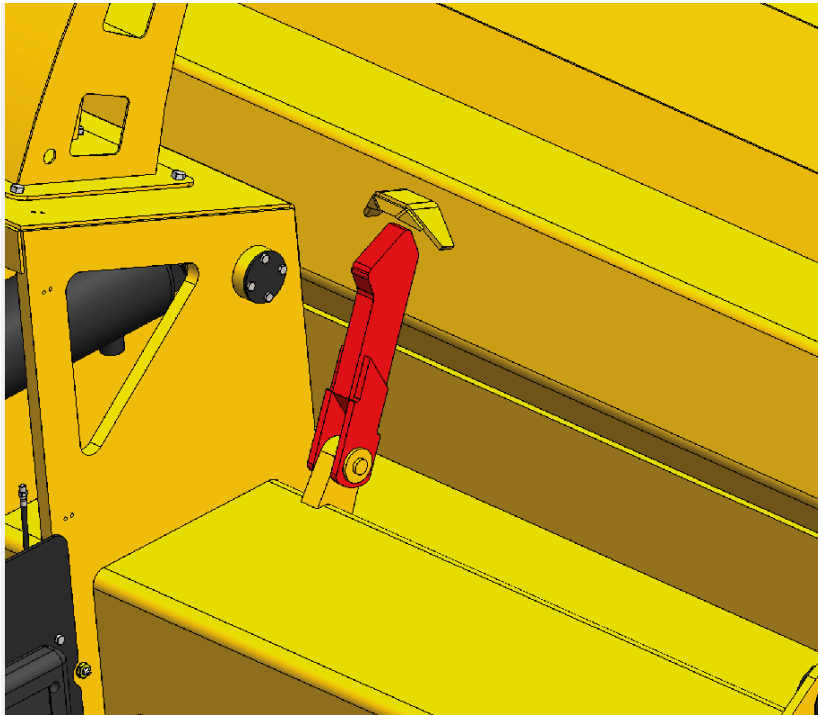

- Lift Cylinder Safety Lock – Put safety lock in when lift cylinders are fully stroked

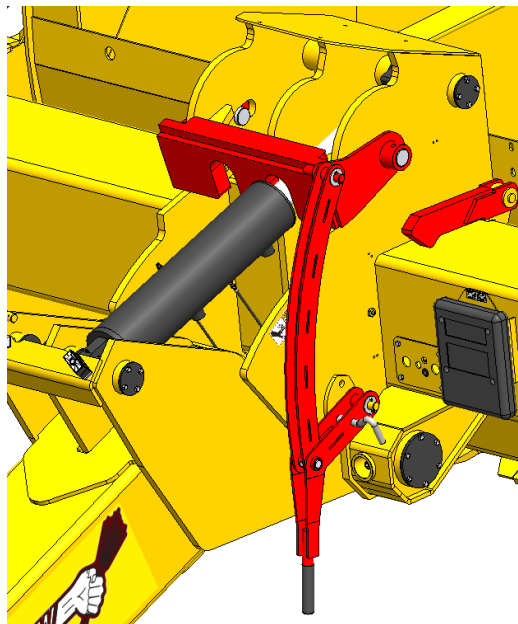

2 OPERATION AND FEATURES

2.1 Operating Scraper unit

NOTE: Most tractor manufacturers recommend loading speed of 4 mph (6.44 km/h) or above.

*NOTE: **Max** oil pressure allowed into the scraper unit is **3,000 psi**. If tractor has capability of applying more pressure there stands a possibility of blowing hydraulic hoses, hydraulic cylinder seals, etc. The **minimum** oil pressure needed to run the scraper unit is **2,200 psi**. The **minimum** hydraulic flow needed to run the scraper is **25 GPM**.*

2.1.1 Operating Guidelines

1. Load in 6th gear or above and target 1900 rpm.
2. Do not shift gears when loading
3. Do not turn when loading
4. Activate differential lock before loading and turn off before transporting
5. Reduce speed when haul roads are rough
6. Do not level ground with apron closed
 - a. If one wishes to level the ground, raise the apron and position the ejector roughly a foot back from the cutting edge
7. Set scrapers cutting edge on the ground when top loading
8. Maintain speeds above 4.4 mph (7.08 km/h) when push loading
9. Maintain tractor wheel hub torque per Operator's Manual
10. Maintain scraper hardware torque per Operator's Manual
11. Complete daily inspections on tractor and scraper

2.1.2 Loading the Scraper

1. Load in the lowest gear although high enough to stall the tractor without spinning the tires. On loose sand this will be a higher gear, on clay it will be a lower gear
2. Operate at full throttle
3. While loading, use the sound of the engine as a reference of how deep the scraper is cutting
 - a. A full scraper load can be achieved by listening to the sound of the engine and adjusting the depth of cut to keep the engine working at full power

4. Apron positioning when loading is critical. Have the apron a foot or two open, from the closed position, so the loose material entering the bowl can rest on the apron and enter the bowl more quickly.
 - a. Ejectors scrapers generally load best with the apron partially closed as the scraper reaches 2/3 to 3/4 capacity.
5. When top loading the scraper make sure to remove the GPS tower to avoid damage.

2.2 Preparing the Tractor

Scraper applications potentially have the power to overload tractors beyond design limits and can affect tractor reliability. Scraper tractors require specifications for ballasts, wheel air pressure, hitch adapter, and tires that differ from typical agricultural applications.

2.2.1 Loading Specifications Table

Model	Capacity (yd ³)	Scraper Weight (lbs.)	Total Weight (lbs.) ^a	Tongue Split	Empty Vertical Hitch Load (lbs.)	Loaded Vertical Hitch Load (lbs.)	Tractor (HP)
Pulldozer 1220A	20 (15.29 m ³)	28,000 (12,700 kg)	78,000 (35,380 kg)	26% (Empty) 28% (Loaded)	7,280 (3,303 kg)	21,840 (9,906 kg)	400 - 600

^a Material Density 2,500 lbs./cu. Yd. (See 2.7.1 table below for material density's)

2.3 Attaching Scraper to Tractor

NOTE: Tractor must have minimum of two hydraulic remotes for a single scraper hookup. Working pressure for 1220A Pulldozer are from 2,200 psi to 3,000 psi

1. Install the quick attach drawbar on the tractor
2. Back tractor into position, within six inches of the scraper's hitch
3. Connect the hydraulic hoses from the scraper to the tractor
 - a. Scraper Hose #1 (Lift Cylinder Base End) – Tractor Hydraulic Remote #1
 - b. Scraper Hose #2 (Lift Cylinder Shaft End) – Tractor Hydraulic Remote #2
 - c. Scraper Hose #3 (Apron & Ejector Cylinder Base End) – Tractor Hydraulic Remote #3
 - d. Scraper Hose #4 (Apron & Ejector Cylinder Shaft End) – Tractor Hydraulic Remote #4

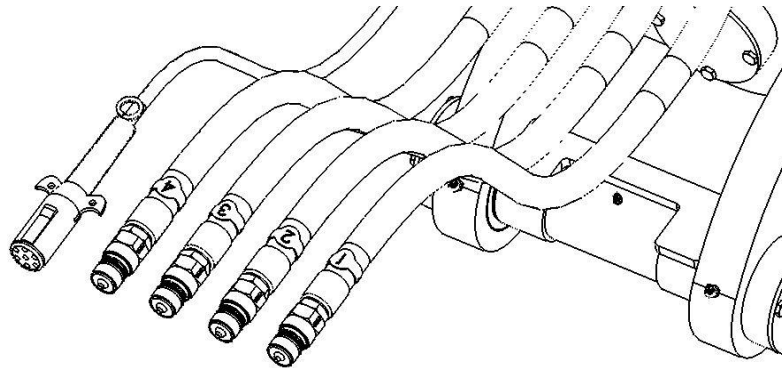
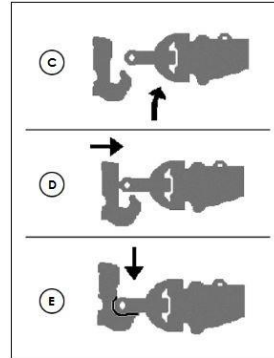
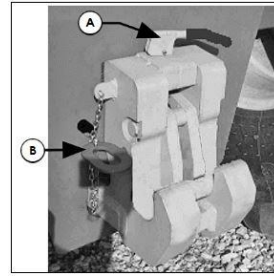

4. Install 7-pin electrical plug to tractor



5. Remove the secondary lock pin (B) from the drawbar or quick attach hitch

6. Pull the locking handle towards you (A)
7. Raise or lower scraper until its tongue matches the drawbar of the tractor (C)
8. Back up tractor until tractor hitch is directly underneath the scraper hitch (D)
9. Lower scraper hitch onto tractor quick attach drawbar (E)
10. Push the locking handle (A) to the down position
11. Insert the secondary locking pin (B)

2.4 *Disconnecting the Scraper from Tractor*

1. Park on level ground
2. Remove locking pin (B)
3. Push locking handle forward (A)
4. Reinsert locking pin to hold hitch in open position
5. Lift scraper until the hitch is higher than the rear quick hitch (F)
6. Drive forward to clear drawbar or quick hitch (G)
7. Lower scraper tongue to the ground/stand (H)
8. Depressurize all hydraulic remotes
9. Disconnect hoses and wire harness

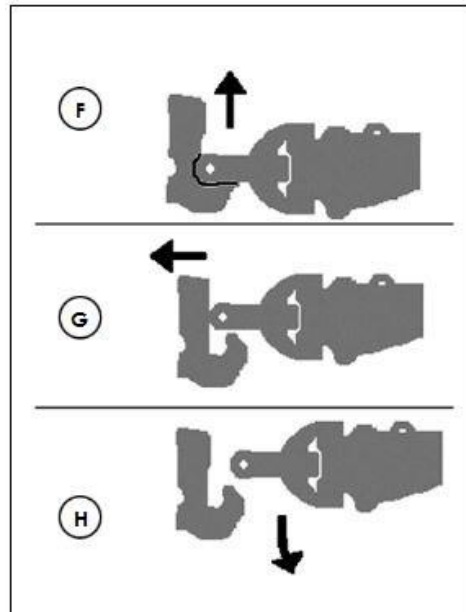

2.5 Top Loading

Top loading can be an efficient way of loading in certain circumstances. Caution **must** be taken when top loading to prevent frame and cylinder stress. **REMOVE** GPS Tower to avoid collision or damage to machine. Top loading can cause two known overloading scenarios:

- **Hitch, Tongue, Frame, and Cylinder Stress - THE SCRAPER**
OPERATOR MUST LOWER the scraper to the ground in such the blades/cutting-edge rests firmly on the ground. This will relieve the shock or spike pressure when material is dropped into the scraper. Make sure tractor is in park or set brake.
- **Exceeding Scraper Capacity** – Top loading material can overload the scraper when the weight per cubic yard surpasses the scraper capacity. This is especially true when loading wet material, which is heavier. To avoid this overload condition, **DO NOT** fill above struck level when top loading.
See chart below on 2.7.1 material density and section 2.10 for struck level

2.6 Push Loading

Push loading can come in handy in certain conditions. When push loading maintain speeds above 4.4 mph (7.08 km/h). **Make sure** you are pushing inline (parallel) with the loading scraper unit to prevent damage and failure to scraper unit.

2.7 Overload Conditions

The warranty of this product applies to only defects in material and workmanship and does not cover parts that fail because of poor maintenance or improper use. Failures due to overload conditions are **NOT** covered. **MAKE SURE** you know the material you are going to be loading then determine to how full you can load the scraper before overloading both the scraper and tractor. Table 2.3.1 Material Density below shows densities of common material.

See Table 2.1.1 Loading Specifications for design limits

Some Scraper overload conditions are:

- Push loading or assist loading
- Transporting scraper at high speeds over rough terrain
- Leveling terrain with the apron closed
- Pulling a scraper by a tractor above the horsepower rating
- Top loading scraper with lift cylinders in raised position
- Jamming or jack knifing the tractor and scraper
- Not properly torquing the bolts as specified in Operator’s Manual
- When top loading, do not fill past struck capacity
- Packing top loaded material with excavator bucket
- Unloading rock into the scraper bowl
- Overloading scraper with dense material
- Overloading tractor design limits

2.7.1 Material Density Table

Material	Density (lb./cu. yd.)
Wood Chips	700
Peat, Dry	750
Peat, Wet	1,170
Cinders	950
Topsoil	1,600
Coal	1,780
Caliche	2,100
Earth, Loam	2,100
Earth, Dry	2,550
Earth, Wet	2,700
Shale	2,250
Sand, Dry	2,400
Sand, Moist	2,850
Sand, Wet	3,100
Sand and Gravel, Dry	2,900
Sand and Gravel, Wet	3,400
Clay, Dry	2,500
Clay, Wet	2,800
Limestone, broken or crushed	2,600
Rock, Granite, Blasted and Broken	2,800

2.8 Hydraulics

There are two sets of hydraulic hoses to connect to the tractor. Each hose has a number marker to identify its function. They should be connected at best convenience for the tractor's controls. Note that hoses are paired in 2's and the following table shows the operation when pushing oil into the hose with the smaller number out of the pairs.

Hose Marker	Standard 2-Remote
1 and 2	Raises Scraper
3 and 4	Opens Apron, Pushes Ejector Forward

2.9 Adjustments

2.9.1 Implement Swivel Hitch

Make sure that the hitch height is adjusted to match your tractor's particular drawbar height.

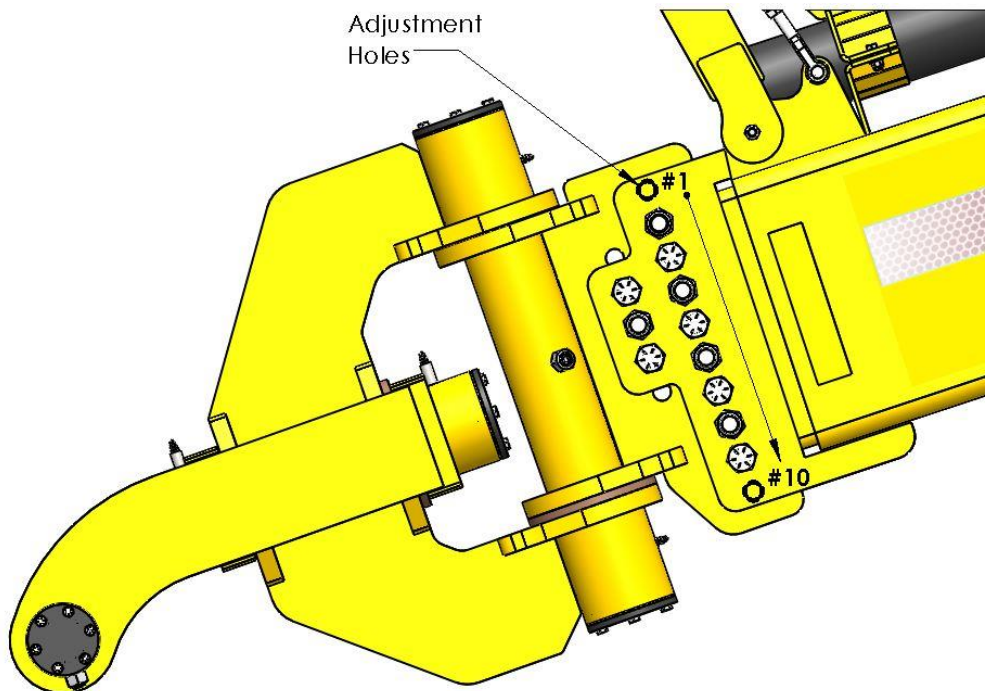

Holes Used	Drawbar Height (inches)
1 -> 8	22.00
2 -> 9	24.00
3 -> 10	26.00

2.9.2 Front Hose Holder

Adjust hose holder to accommodate your tractor. Make sure hydraulic hoses are out of the way of any pinch points.

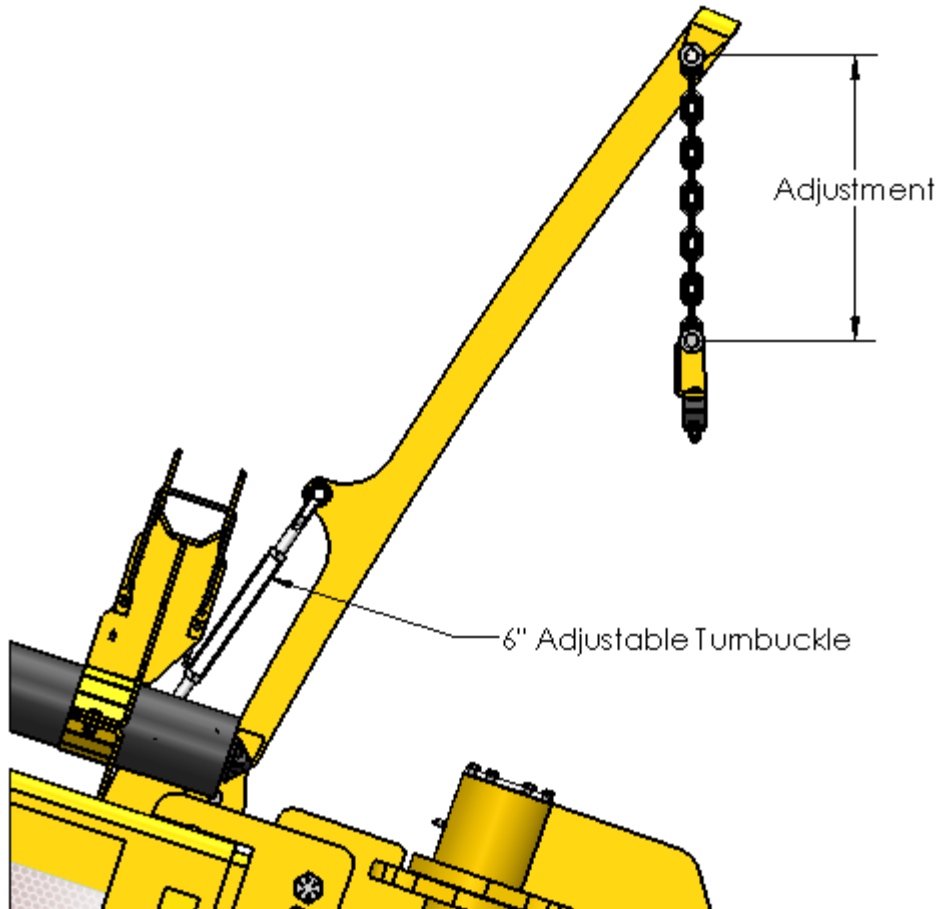

2.9.3 Cutting Depth Indicator

The Pulldozer 1220A is equipped (standard) with a cutting depth indicator. The values on the decal represent inches. This gives the operator a sense of knowledge on how deep the cutting edges is piercing the material. To properly set the height indicator needle in section **4.3.2 Front Add-Ons** you must be on level ground. Put cutting edge on ground, not penetrating earth just resting, then center the needle between the “0” section by loosening the two 3/8” x 1-1/4” bolts and 3/8” nylon lock nuts. Adjust accordingly then tighten up hardware.



2.9.4 Apron Height Indicator

The Pulldozer 1220A is equipped (standard) with an apron height indicator. The values on the decal represent inches. This gives the operator a sense of knowledge on where the apron cutting edge is compared to being closed. To properly set the height indicator needle in section **4.3.2 Front Add-Ons**, you must be on level ground. De-stroke apron cylinder until it is fully destroke. Install apron needle then adjust accordingly then tighten up hardware.

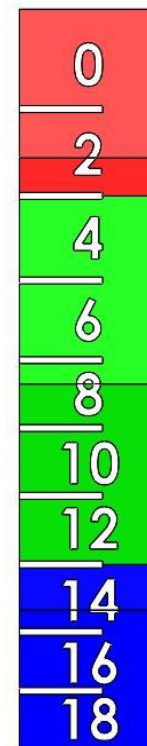

2.9.5 Sequence Apron and Ejector Valve

The scrapers sequence valve blocks (x2), which includes the ejector valve sequence cartridge and apron sequence valve cartridge, is used to control two hydraulic circuits with one hydraulic remote. **The scraper should be empty for adjusting sequence valve cartridge.** The valves may need to be adjusted for different tractor flow/pressure combinations for proper function of the apron and ejector.

Max oil pressure allowed into the scraper unit is **3,000 psi**. If tractor has capability of applying more pressure there stands a possibility of blowing hydraulic hoses, hydraulic cylinder seals, etc. The **minimum** oil pressure needed to run the scraper unit is **2,500 psi**. The **minimum** hydraulic flow needed to run the scraper is **25 GPM**.

When installing a pressure gauge between the tractor and sequence valve the sequencing pressure is to be **2000 psi** for both sequencing valves. See hydraulic schematic on next page on where to install pressure gauge.

When introducing oil into number 3 hydraulic hose the apron will fully open, the oil pressure will reach **2000 psi**, then the sequencing valve will switch and the ejector will push forward (pushing dirt out of the bowl). When introducing oil into the number 4 hydraulic hose the ejector shall retract, the oil pressure will reach **2000 psi**, then the sequencing valve will switch and then the apron will fully close. If the operation of this procedure differs refer to below procedures.

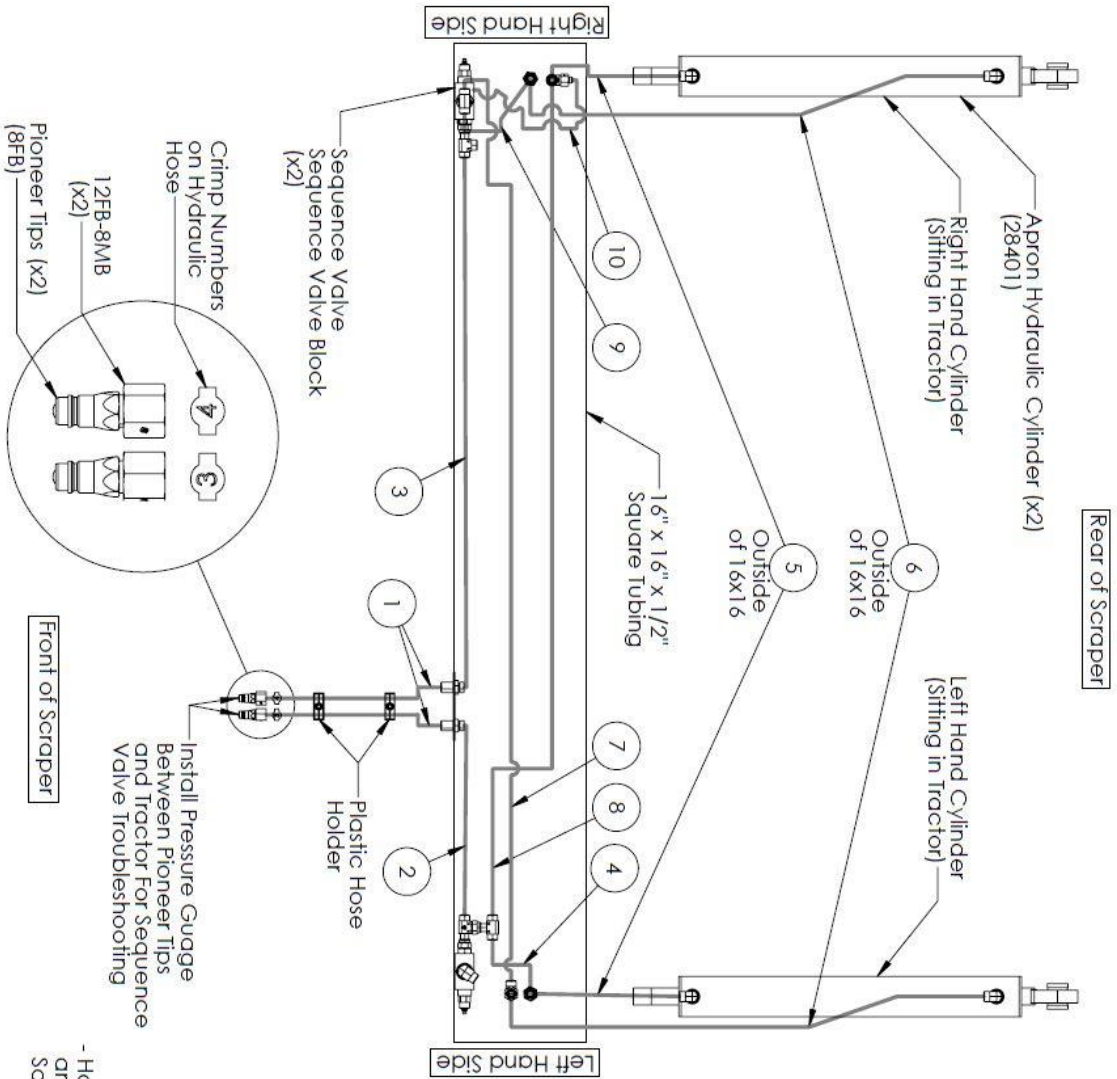

Hose #	Length (inches)	Ends	Qty
1	213	12MB-12FORFSX90	2
2	34	12MB-12FORFSX90	1
3	67	12MB-12FORFSX90	1
4	17.75	12MB-12FORFSX	1
5	19.5	12MB-12FORFSX	2
6	57	12MB-12FORFSX	2
7	138	12MB-12FORFSX90	1
8	125	12MB-12FORFSX45	1
9	52	12MB-12FORFSX90	1
10	23.25	6MB-6FORFSX45	1

- Hose Numbers 2, 3, 4, 7, 8, 9 and 10 are all within the 18" x 16" x 1/2" Square Tubing

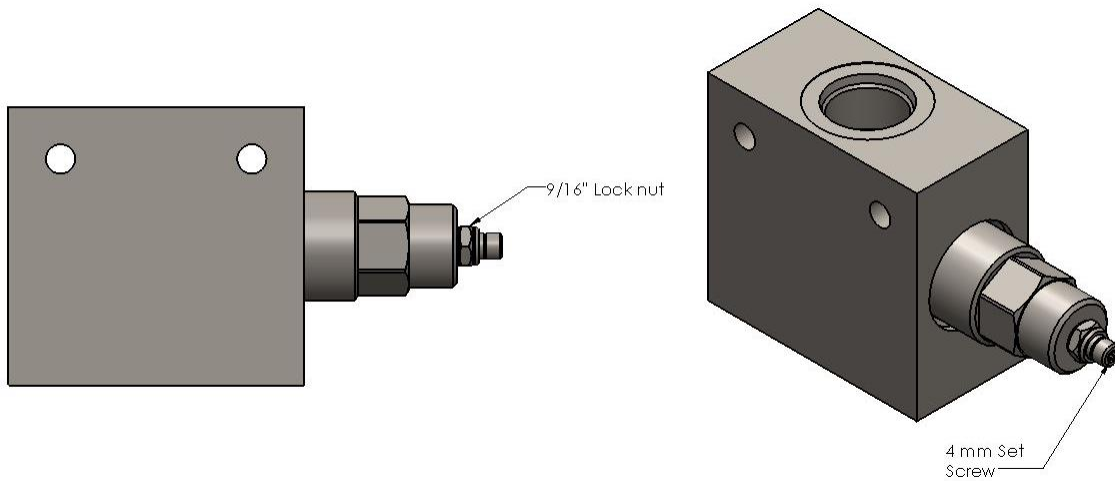

Left Hand Side Sequence Valve Cartridge Procedure (Apron opens then ejector extends forward):

1. Loosen lock nut (9/16") on sequence valve cartridge
2. Activate tractor hydraulic remote (3)
3. Turn set screw (4 mm) clockwise until apron opens (rises), before the ejector cylinder proceeds to open.
4. Turn the set screw an additional ¼ turn clockwise and tighten lock nut (9/16")
5. Install pressure gauge between tractor and sequence valve then go through the sequence to check sequencing pressure. Should be **2000 psi**.

Right Hand Side Sequence Valve Cartridge Procedure (Ejector retracts backwards then apron closes):

1. Loosen lock nut (9/16") on sequence valve cartridge
2. Activate tractor hydraulic remote (4)
3. Turn set screw (4 mm) clockwise until apron holds in a raised position while ejector cylinder is being retracted
4. Turn the set screw an additional ¼ turn counter-clockwise and tighten lock nut (9/16")
5. Install pressure gauge between tractor and sequence valve then go through the sequence to check sequencing pressure. Should be **2000 psi**.

2.9.6 Ejector Clearance

The rollers are on a cam shaft to make it adjustable to increase or decrease the clearance between the ejector and bowl floor. To adjust do the following steps below: (See illustration below)

1. Be sure ejector edge is clear of dirt or debris before adjusting
2. Loosen the clamp bolt (A)
3. To allow for clearance between ejector and the bowl floor, rotate roller shaft (B) clockwise. (opposite rotation on opposite roller)
4. To decrease clearance between ejector and bowl floor, rotate roller shaft (B) counter-clockwise. (opposite rotation on opposite roller)
5. Once done adjusting clearance, tighten clamp bolt (A)
6. Repeat steps 1 thru 4 to adjust the other floor roller.
7. Start the tractor engine and move the ejector forward and backwards.
8. Shut tractor off and re-check clearance. Repeat adjustment procedure if necessary.

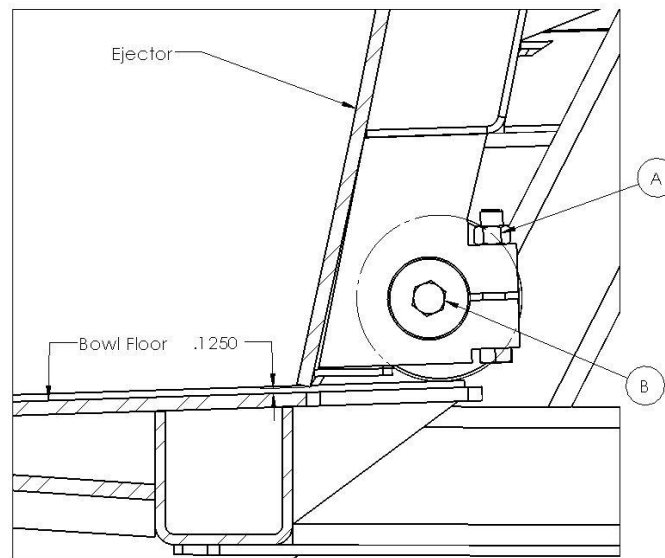

2.10 *Optional Lead Scraper Kit*

The Pulldozer 1220A can be outfitted with a lead scraper kit (30889) to be able to pull two scrapers in a train, allowing twice as much dirt to be moved. This kit can be purchased from Bridgeview Manufacturing or a registered dealer.

Lead Scraper

Pup Scraper

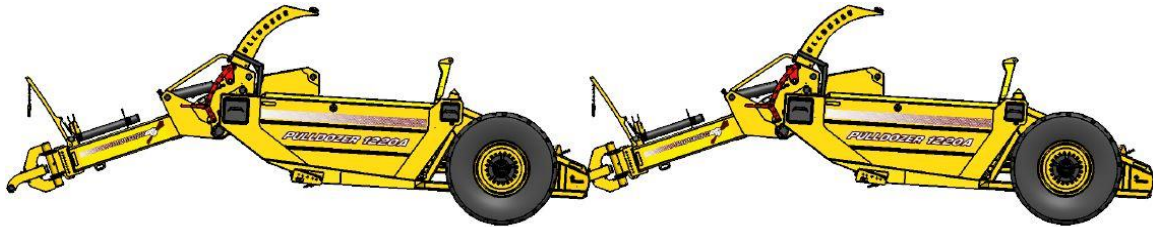

2.10.1 Lead Scraper Parts Book

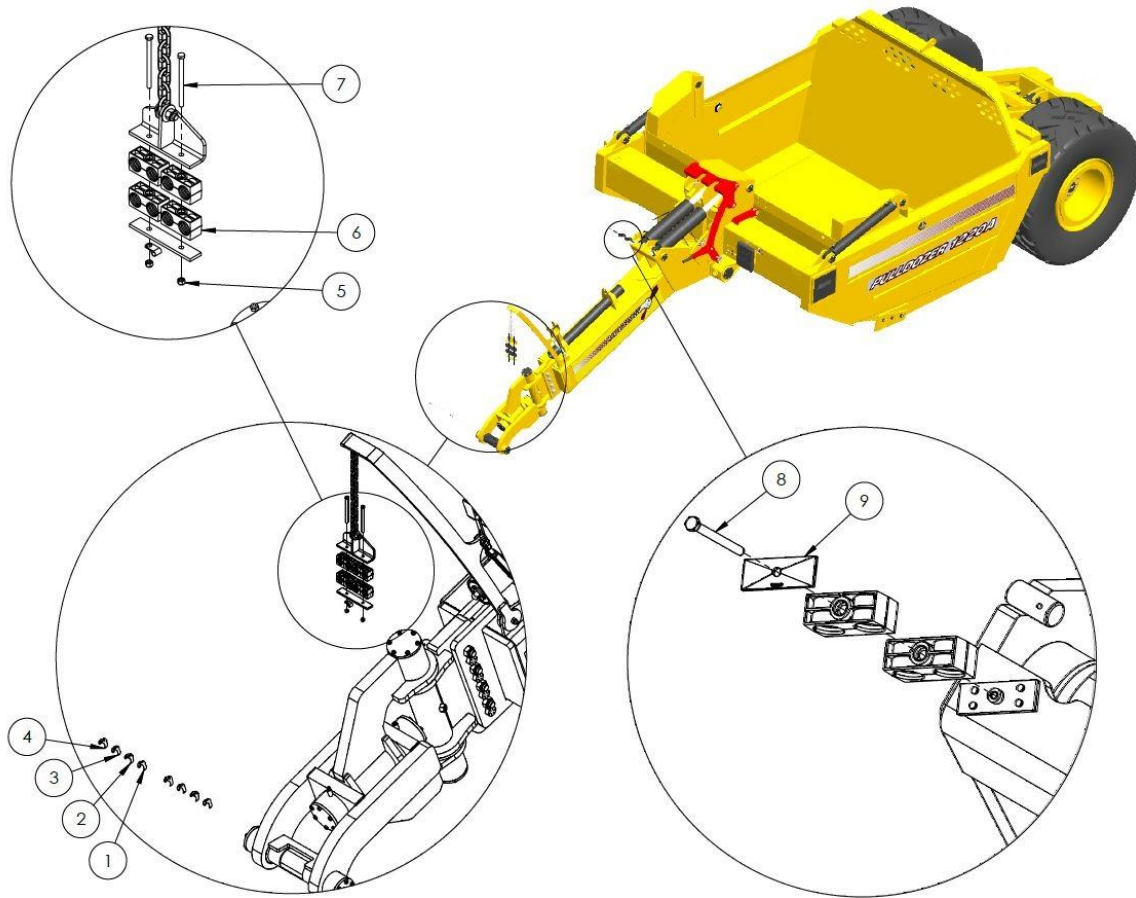

	Description	ID #	QTY		Description	ID #	QTY
1	Hose Band - 1	28267	1	6	Plastic Hose Holder	28414	8
2	Hose Band - 2	28268	1	7	Bolt, 5/16" x 4-1/2"	21836	2
3	Hose Band - 3	28269	1	8	Bolt, 5/16" x 3-1/2"	30914	1
4	Hose Band - 4	28270	1	9	Plastic Hose Holder Cover Plate	28413	1
5	Nylon Lock Nut, 5/16	11815	2				

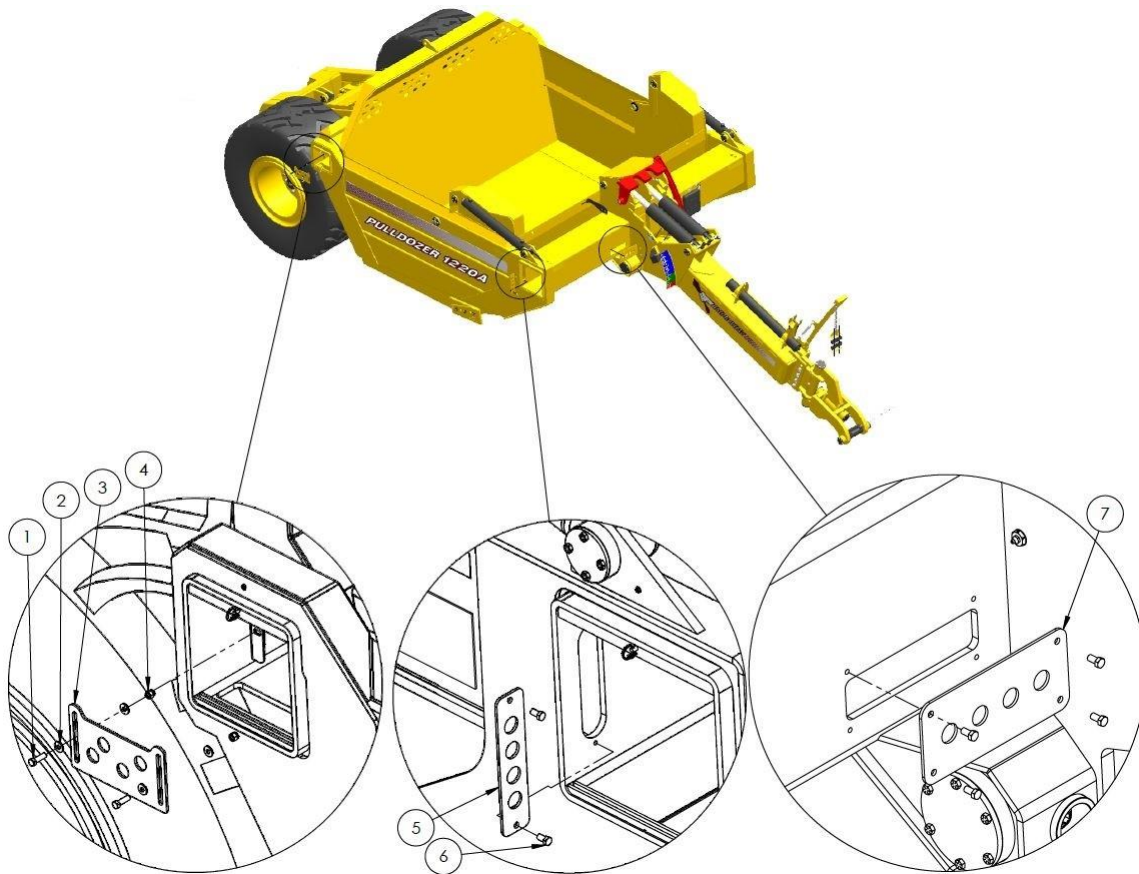

	Description	ID #	QTY		Description	ID #	QTY
1	Bolt, 3/8" x 1-1/4"	10253	2	5	Lead Scraper Bulkhead C (S/N PD1269 & Up)	30904	1
2	Flat Washer, 3/8"	11667	4				
3	Lead Scraper Bulkhead A	30906	1	6	*Bolt, 3/8" x 3/4"	11816	2
4	Nylon Lock Nut, 3/8	10806	2	7	Lead Scraper Bulkhead C	30904	1
5	Lead Scraper Bulkhead B (S/N PD1268 & Down)	30908	1				

***Reuse existing 3/8" x 3/4" bolt (x4) on Lead Scraper Bulkhead C (30904)**

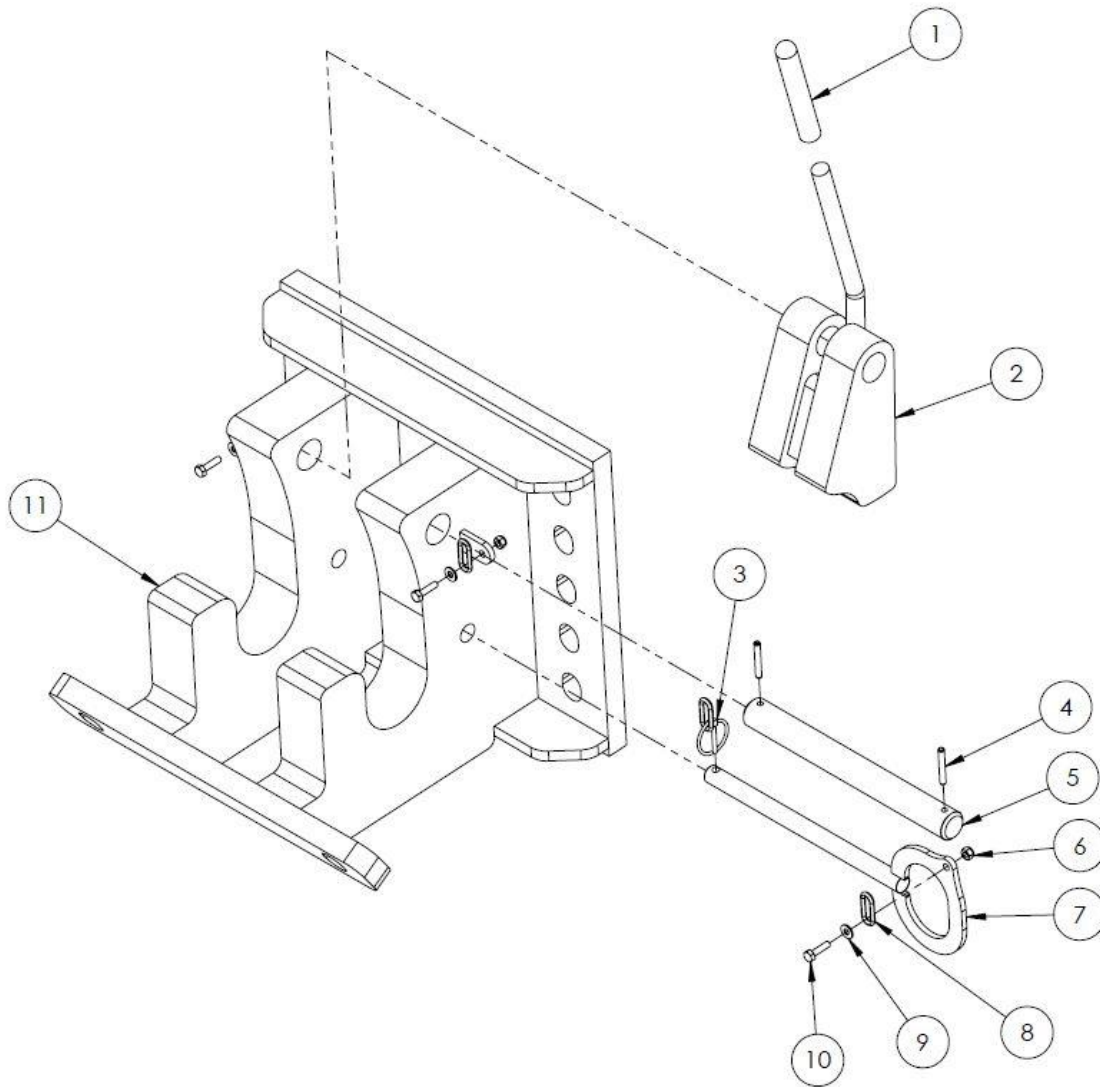

	Description	ID #	QTY		Description	ID #	QTY
1	Yellow Rubber Handle Grip	11796	1	6	Nylon Lock Nut, 1/4"	11614	3
2	Main Lock	29518	1	7	Lock Pin	28611	1
3	Lynch Pin, 3/16" x 1-1/4"	13233	1	8	Plated Chain, 3/16" x 20" Long	11618	2
4	Roll Pin, 1/4" x 1-3/4"	28589	2	9	Flat Washer, 1/4"	11666	3
5	Main Lock Shaft	29518	1	10	Bolt, 1/4" x 1"	11810	3

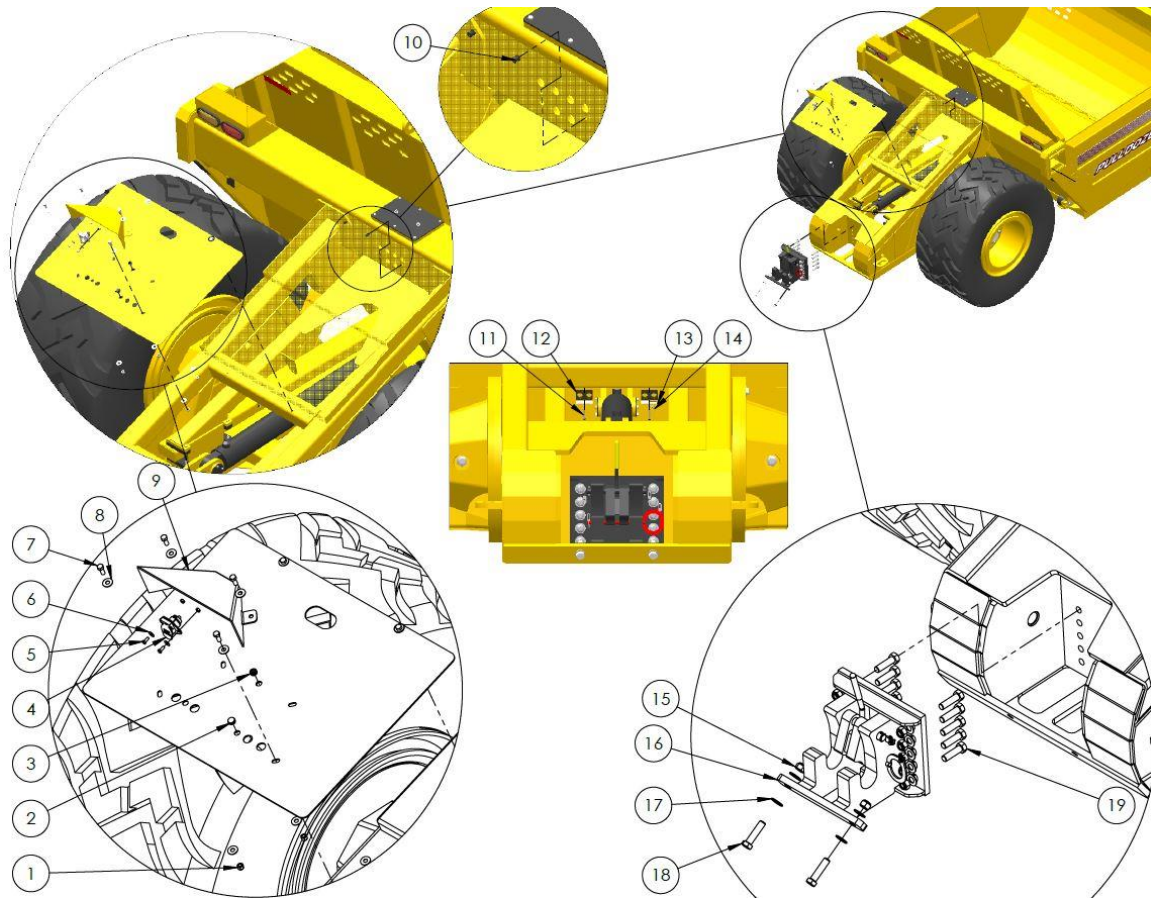

	Description	ID #	QTY		Description	ID #	QTY
1	Nylon Lock Nut, 1/2"	10241	4	11	Bolt, 5/16" x 2"	30915	2
2	Rubber Diaphragm Grommet	30796	1	12	Plastic Hose Holder	28414	4
3	Rubber Wire Grommet	21428	1	13	Plastic Hose Holder Cover Plate	28413	2
4	7-Pin Round Socket	29621	1	14	Cable Clamp	13629	2
5	Bolt, 5/16" x 3/4"	20903	2	15	Stover Lock Nut, 1" Gr. 8 Fine Thread	21104	12
6	Flat Washer, 5/16"	12496	2	16	Lead Scraper Rear Hitch	30897	1
7	Bolt, 1/2" x 1-1/4"	10240	4	17	Flat Washer, 1"	14472	14
8	Flat Washer, 1/2"	11668	8	18	Bolt, 1" x 4" Gr. 8 Fine Thread	28555	2
9	Rear Hose Dirt Deflector	30891	1	19	Bolt, 1" x 3-1/2" Gr. 8 Fine Thread	30913	10
10	Rubber Grommet	30797	2				

2.10.2 Lead Scraper Hydraulic Schematic

Hose #	Length (Inches)	Ends	Qty
1	213	12MB-12FORFSX 90	4
2	49	12FORFSX-12FORFSX 45	1
3	52	12FORFSX-12FORFSX 45	1
4	55	12FORFSX-12FORFSX 45	1
5	58	12FORFSX-12FORFSX 45	1
6	143	12FORFSX-12FORFSX 90	2
7	146	12FORFSX-12FORFSX 90	2
8	65	12FORFSX-12FORFSX 45	1
9	67	12FORFSX-12FORFSX 45	1
10	69	12FORFSX-12FORFSX 45	1
11	71	12FORFSX-12FORFSX 45	1
12	74	12FORFSX-12FORFSX 90	4

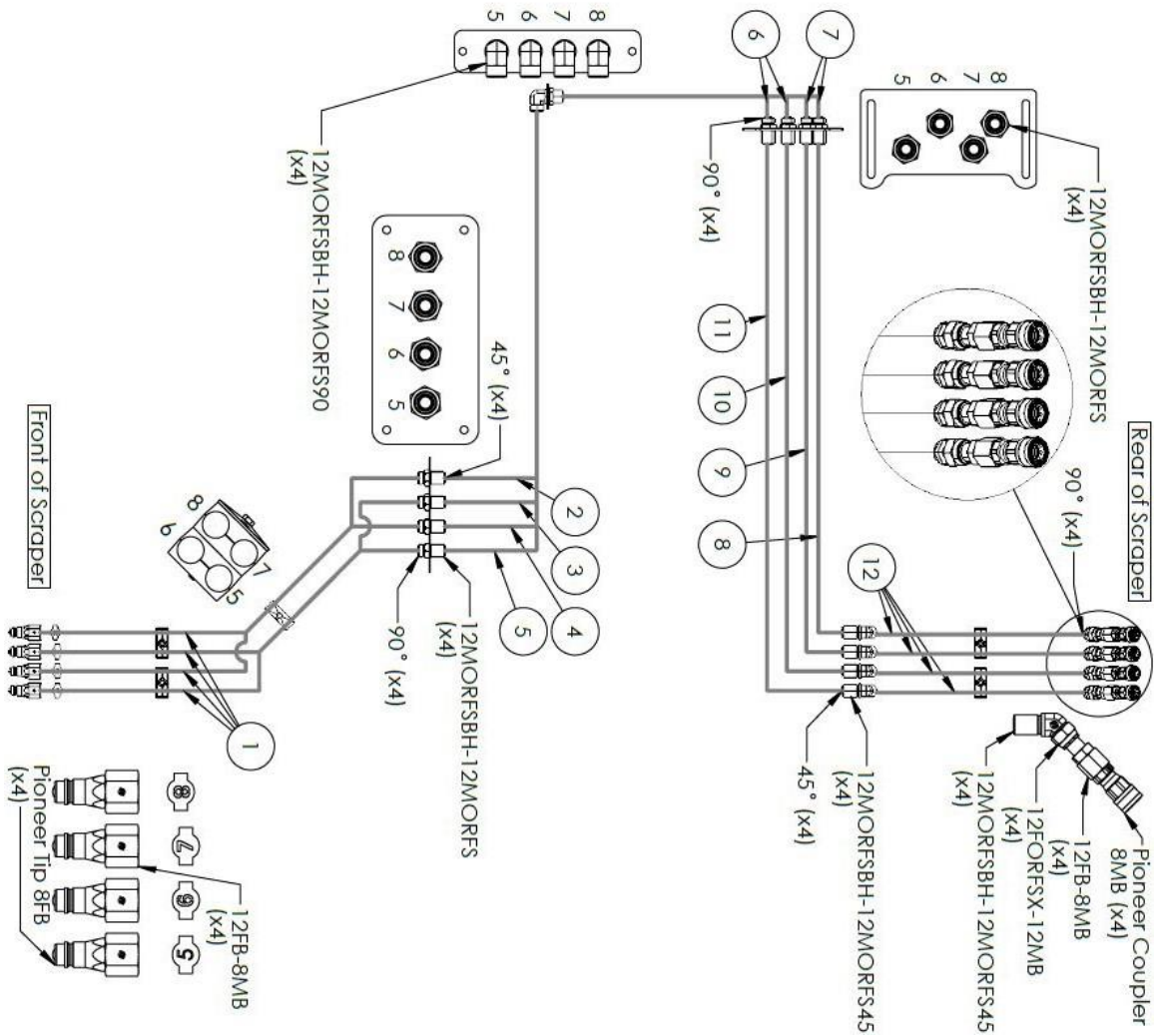

(S/N PD1268 & Down)

Hose #	Length (Inches)	Ends	Qty
1	213	12MB-12FORFSX 90	4
2	49	12FORFSX-45	1
3	52	12FORFSX-45	1
4	55	12FORFSX-45	1
5	58	12FORFSX-45	1
6	143	12FORFSX-90	2
7	146	12FORFSX-90	2
8	65	12FORFSX-45	1
9	67	12FORFSX-45	1
10	72	12FORFSX-45	2
11	74	12FORFSX-90	4

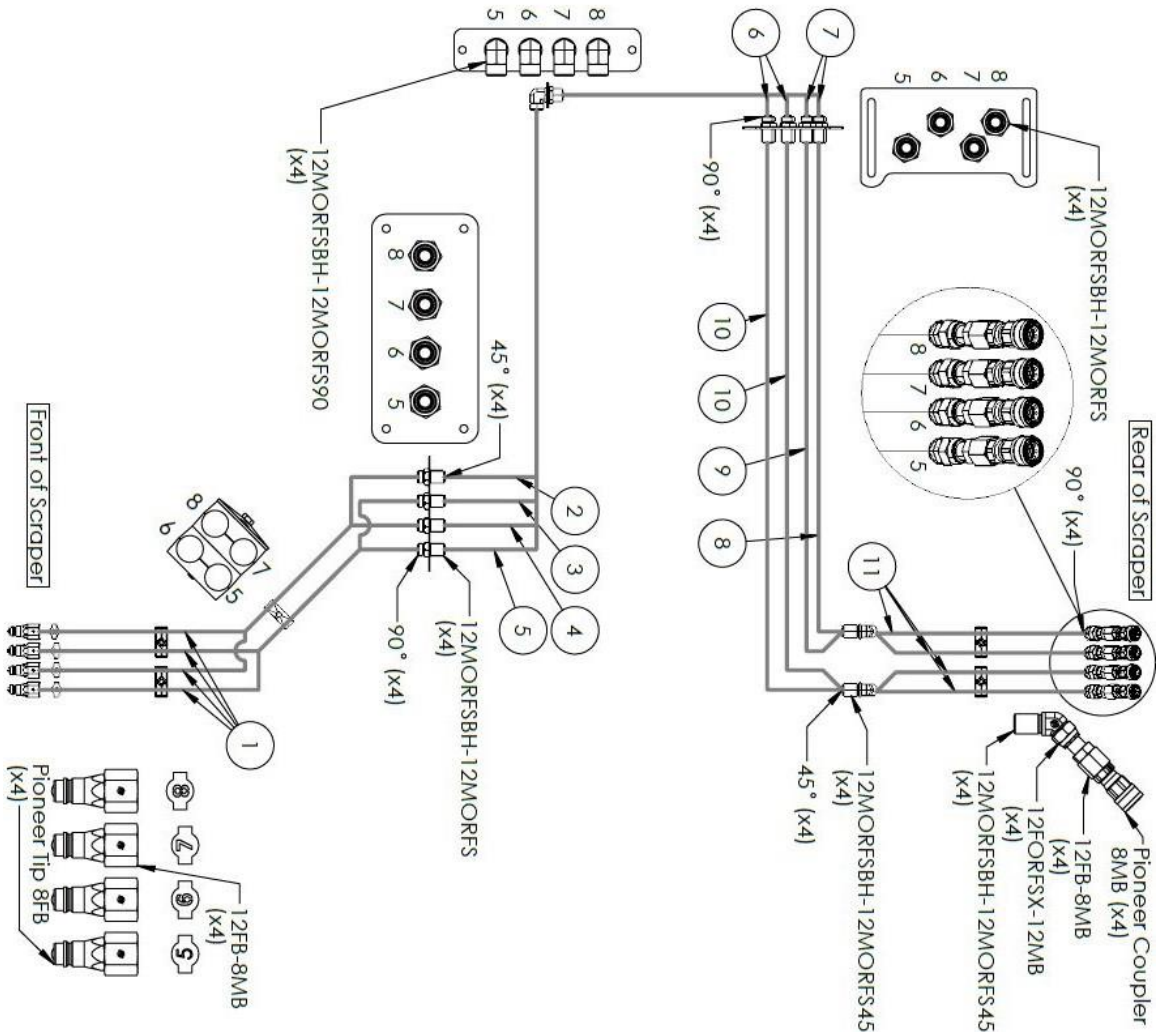

(S/N PD1269 & Up)

2.10.3 Lead Scraper Electrical Schematic

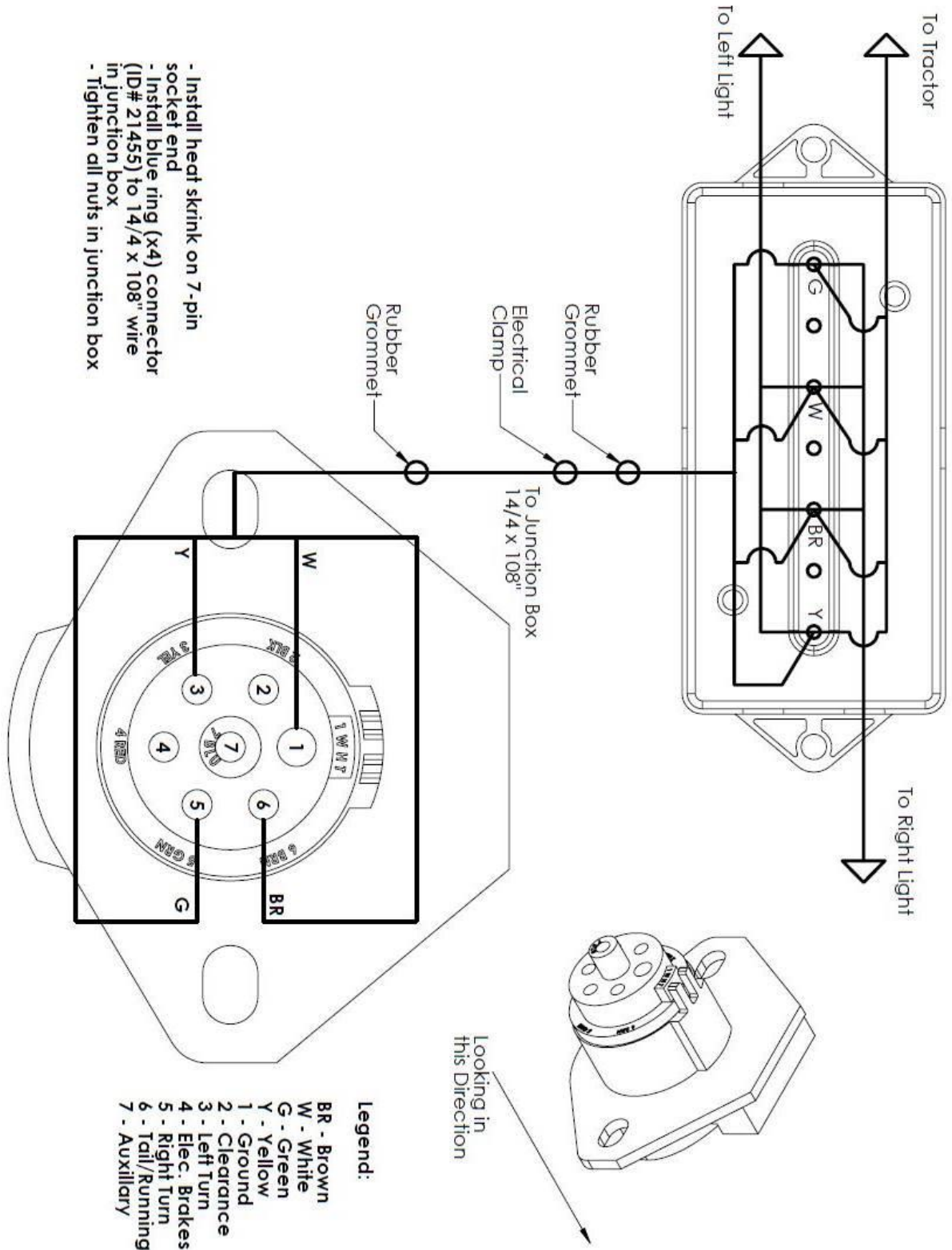

2.11 Optional GPS Tower Kit

The Pulldozer 1220A can be outfitted with a GPS Tower Kit (30826) to be able to accurately manipulate your soil. This kit can be purchased from Bridgeview Manufacturing or a registered dealer.

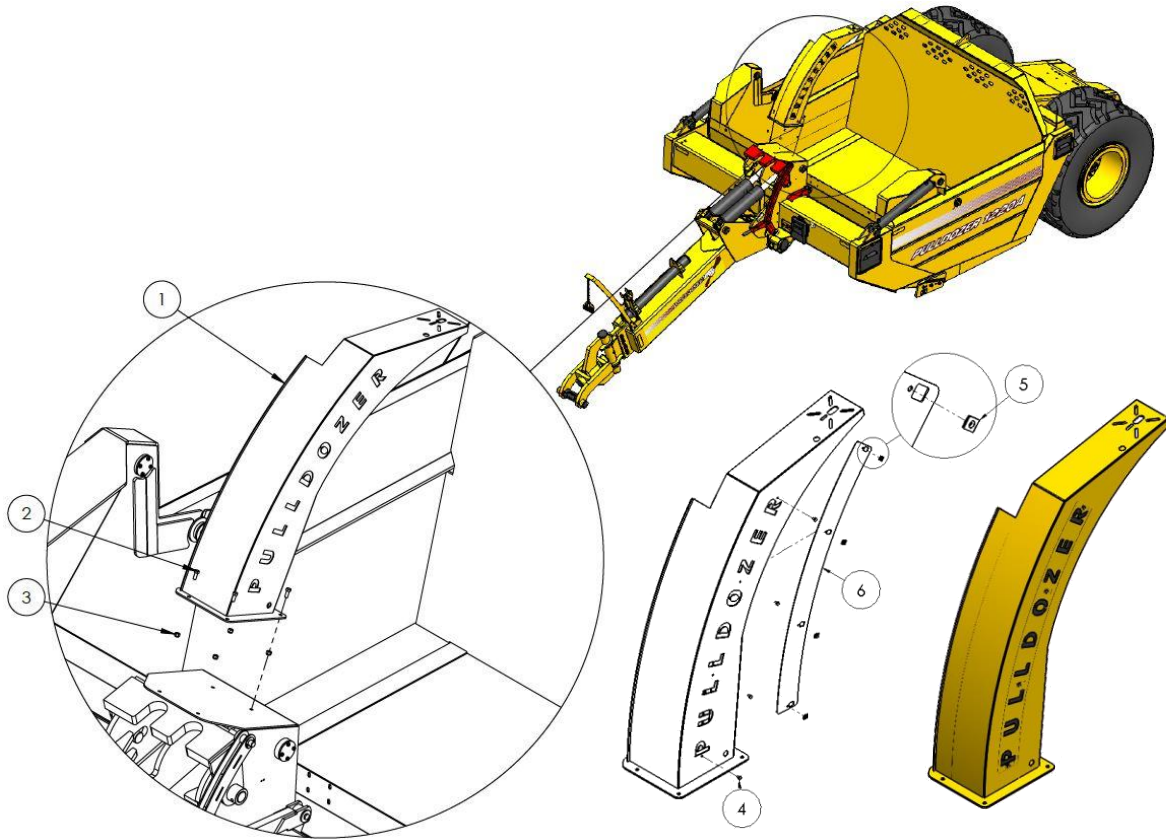

	Description	ID #	QTY		Description	ID #	QTY
1	GPS Tower	30803	1	4	Bolt, 1/4" x 1/2"	24415	8
2	Bolt, 1/2" x 1-1/4"	10240	4	5	Panel Nut, 1/4"	31371	8
3	Nylon Lock Nut, 1/2"	10241	4	6	GPS Letter Cover	31334	2

2.12 Optional GPS Tower and Height Indicators Kit

The Pulldozer 1220A can be outfitted with a GPS Tower and Height Indicators Kit (30828) to be able to accurately manipulate your soil. The height indicators will give you a great understanding where both the cutting edges and apron edge. This kit can be purchased from Bridgeview Manufacturing or a registered dealer.

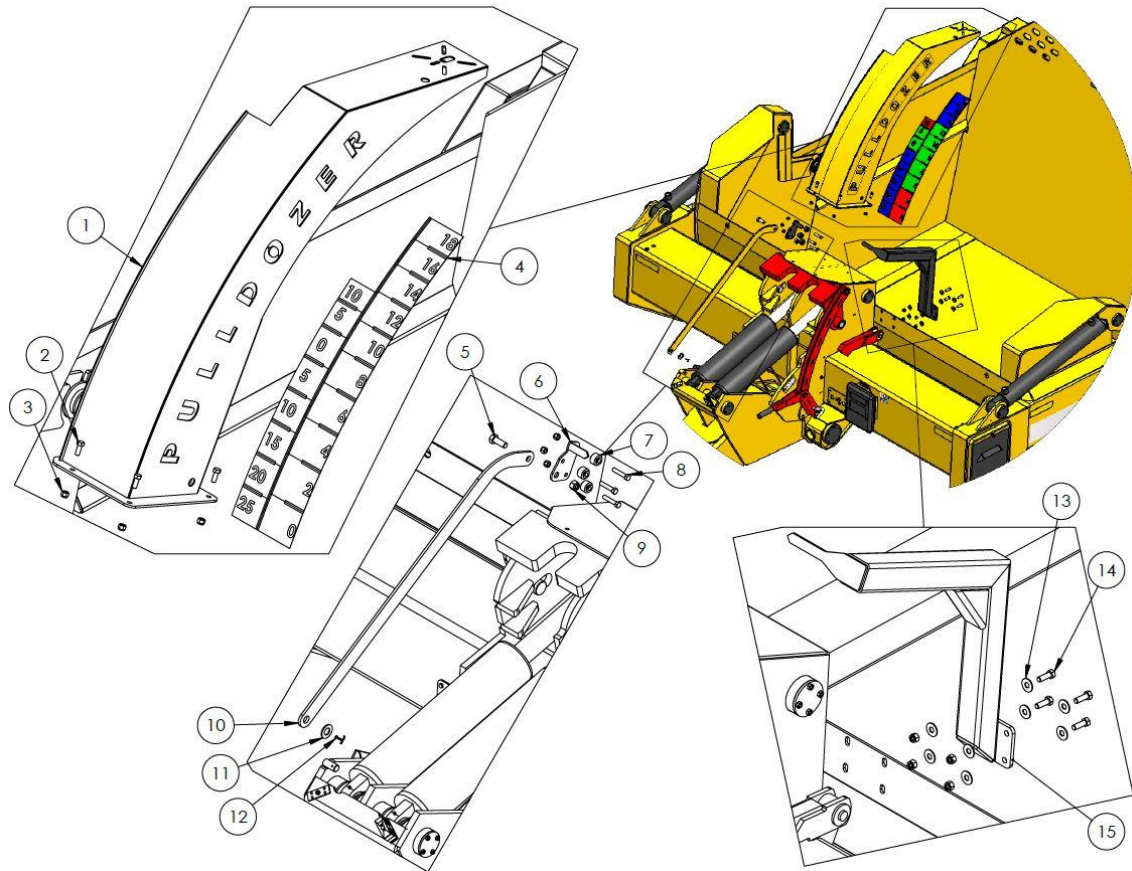

(S/N PD1268 & Down)

	Description	ID #	QTY		Description	ID #	QTY
1	GPS Tower	30803	1	9	Stover Lock Nut, 3/4"	11823	1
2	Bolt, 1/2" x 1-1/4"	10240	4	10	Height Indicator Arm	30818	1
3	Nylon Lock Nut, 1/2"	10241	4	11	Flat Washer, 1"	14472	1
4	Apron/Blade Height Decal *	30831	1	12	Cotter Pin, 3/16" x 1-1/2"	10072	1
5	Bolt, 3/4" x 2"	13800	1	13	Flat Washer, 1/2"	11668	8
6	Height Indicator Needle	30816	1	14	Bolt, 1/2" x 1-1/2"	10174	4
7	Roller	11637	3	15	Apron Height Indicator Arm	30819	1
8	Bolt, 1/2 x 2-1/2"	10804	3				

* Install decal when lift cylinders are fully stroked and apron cylinders are fully destroyed

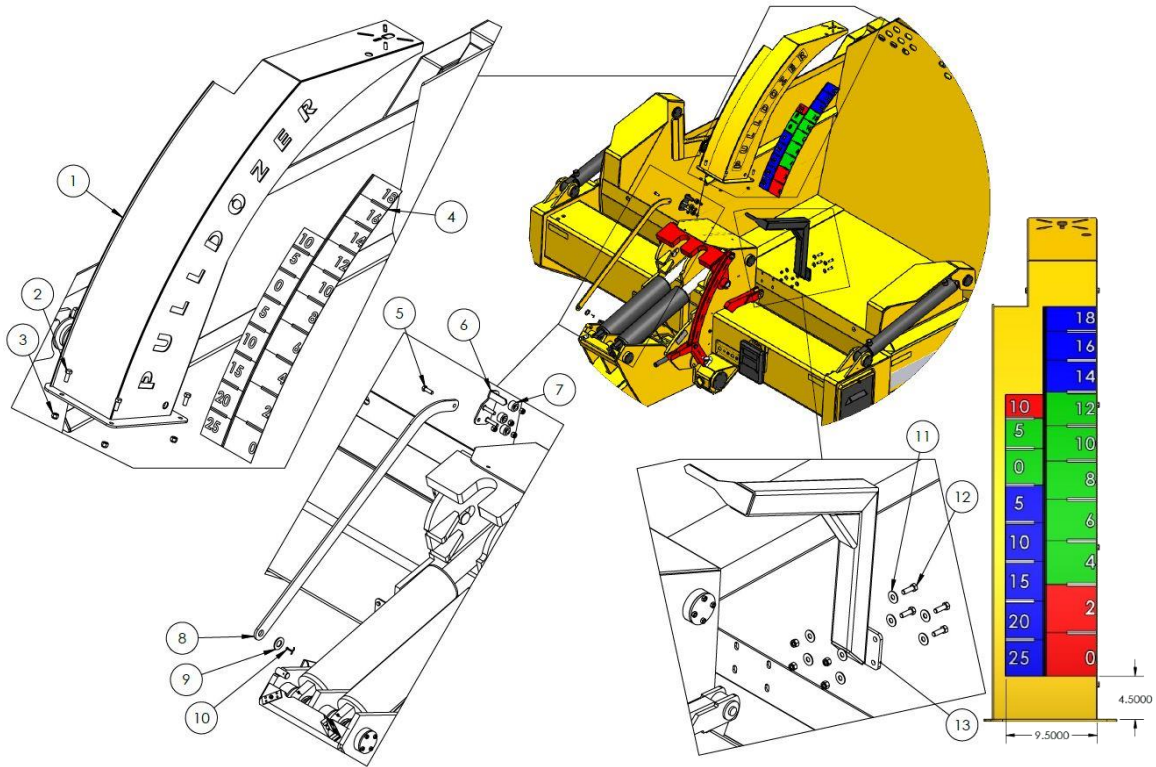

(S/N PD12269 & Up)

	Description	ID #	QTY		Description	ID #	QTY
1	GPS Tower	30803	1	8	Height Indicator Arm	31349	1
2	Bolt, 1/2" x 1-1/4"	10240	4	9	Flat Washer, 1"	14472	1
3	Nylon Lock Nut, 1/2"	10241	5	10	Cotter Pin, 3/16" x 1-1/2"	10072	1
4	Apron/Blade Height Decal *	30831	1	11	Flat Washer, 1/2"	11668	8
5	Bolt, 1/2" x 1-1/2"	10174	1	12	Bolt, 1/2" x 1-1/2"	10174	4
6	Height Indicator Needle	31330	1	13	Apron Height Indicator Arm	30819	1
7	Roller	11637	3				

* Install decal when lift cylinders are fully stroked and apron cylinders are fully destroyed

Apron Height Indicator Location:

The apron height indicator arm has two positions you can install it on. Position 1 is if you WERE NOT using a GPS antenna. Position 2 is if you WERE using a GPS antenna. This allows you to have great knowledge of where the apron edge is at all times.

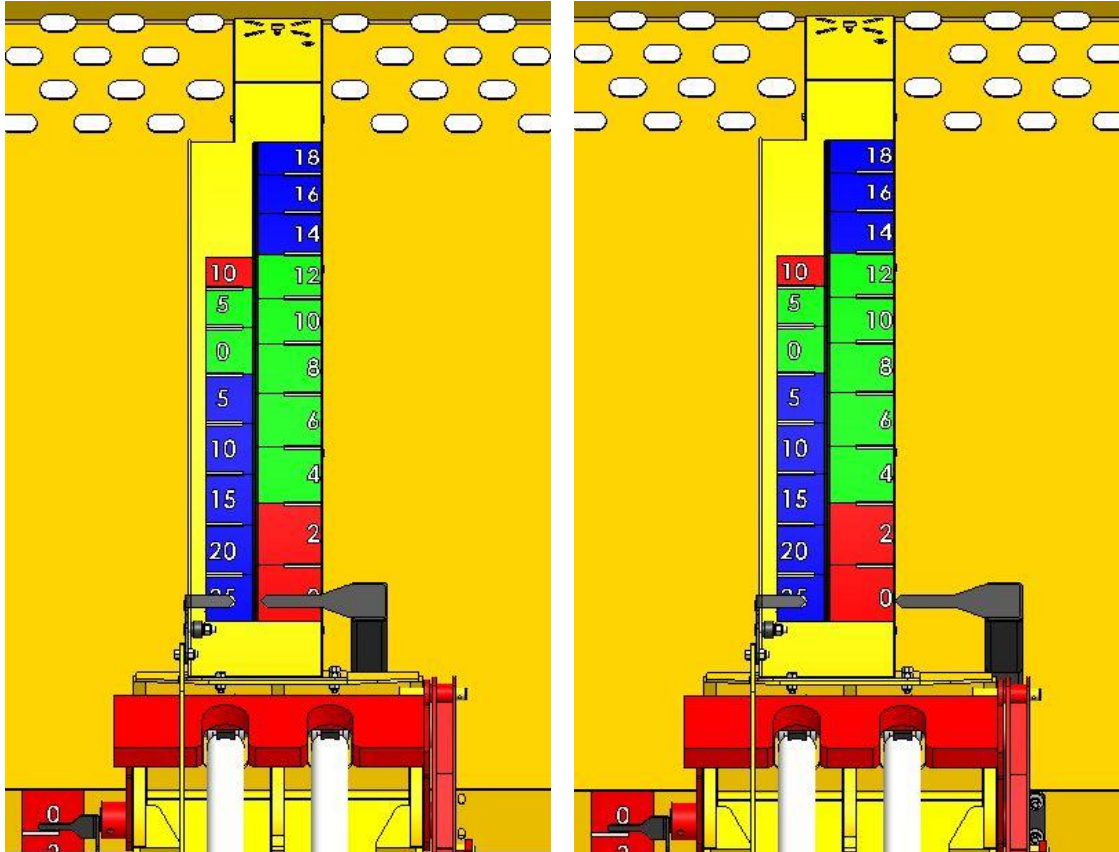

Position 1

Position 2

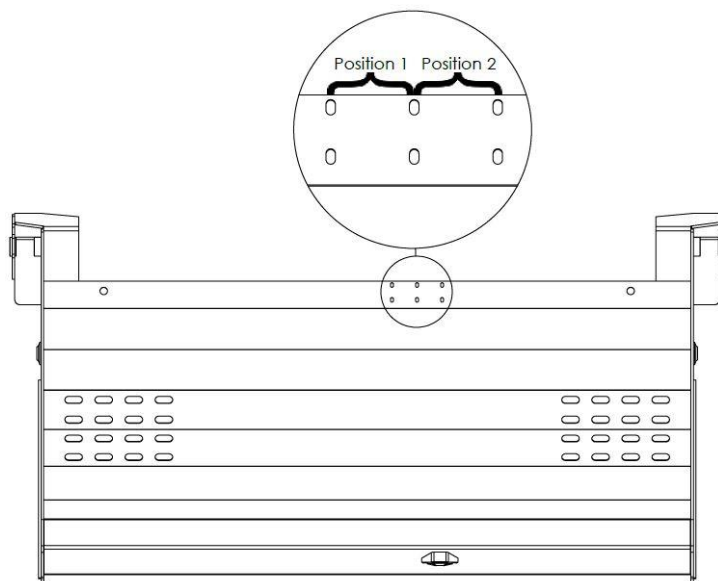

2.13 Optional Brake Kit

If you are looking for more stopping power the Pulldozer 1220A can be outfitted with a Brake Kit (31271) in order to meet your braking needs. This kit can be purchased from Bridgeview Manufacturing or a registered dealer. You are to supply your own male pioneer end to install on the hose ends to match your current tractor.

2.13.1 Hook-Up/Operation

1. Connect the “pressure” hose to the tractor’s “Brake Port” (If not available you need “Optional Tractor Brake Kit” (31272)). This allows the preferred operation of the scrapers brake assist system which should automatically be activated when the tractors brakes are applied.

2.13.1 Bleeding Hydraulics

It is important to bleed any air out of the hydraulic braking system before operation. This will need to be completed on Air Bleed Vents on each of the 4 brake caliper assemblies.

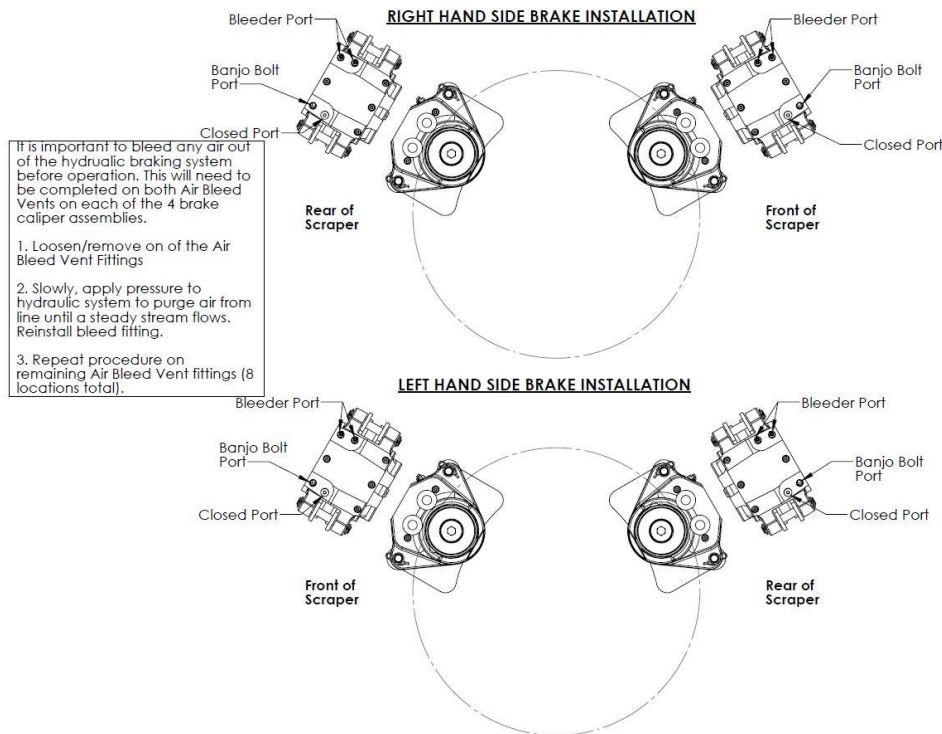

2.13.2 Centering Rotor on Brake Assembly

When installing the Brake Assembly, it is important to install the brake rotor within the center of the brake pads.

1. Bolt brake caliper onto the scraper.
2. Loosen **1" set screw** and **1-1/4" x 9" bolt** to adjust the rotor from left to right
3. Adjust so that the rotor is in the middle of two brake pads
4. Retighten **1" set screw** and **1-1/4" x 9" bolt**.

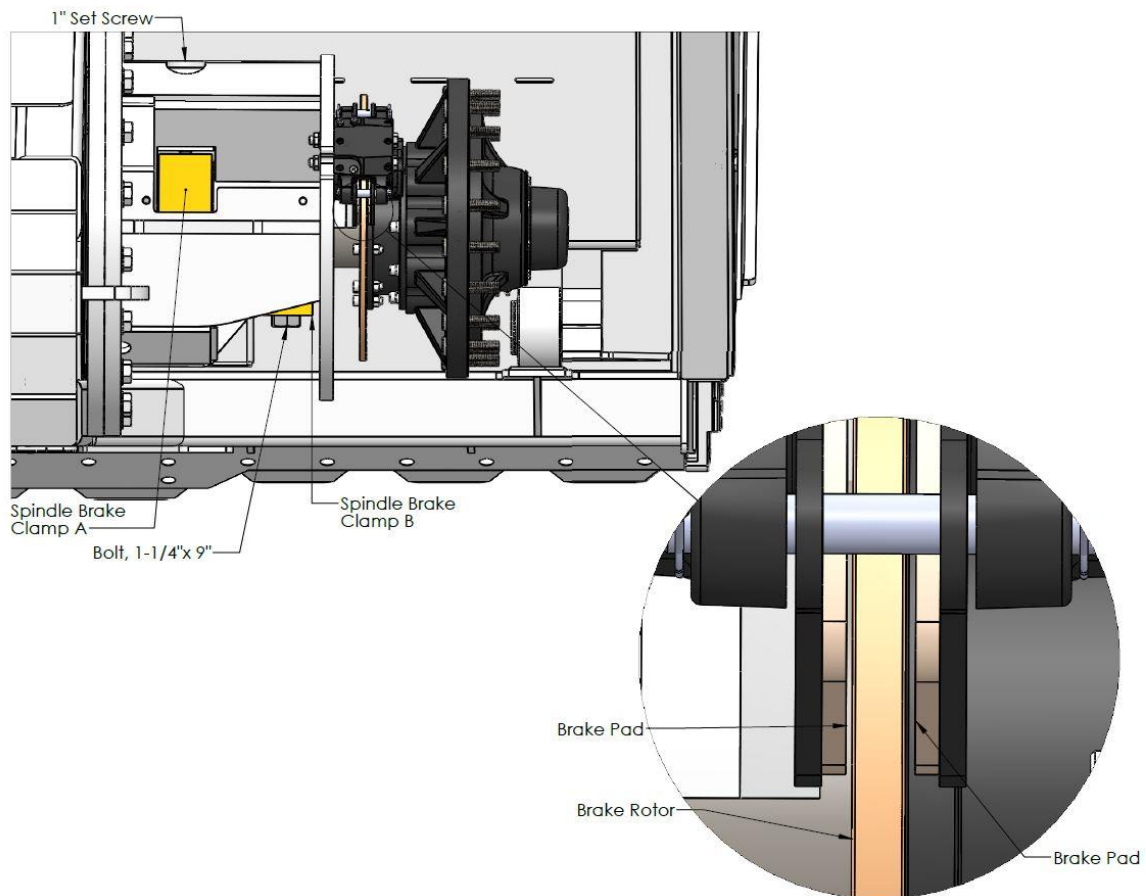

2.13.3 Brake Assembly

By using the following diagrams, as shown below, you can install your brake kit with ease.

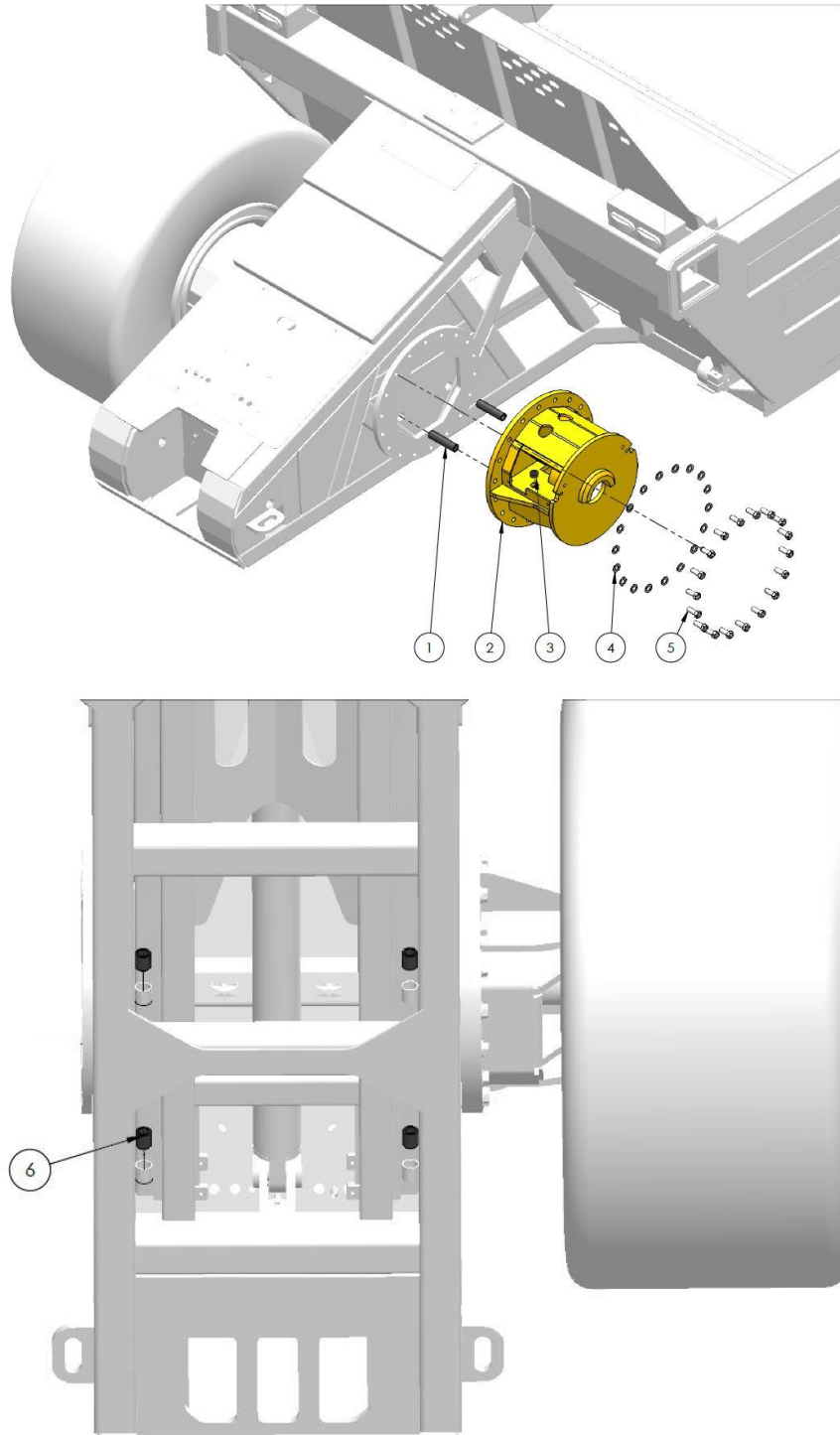

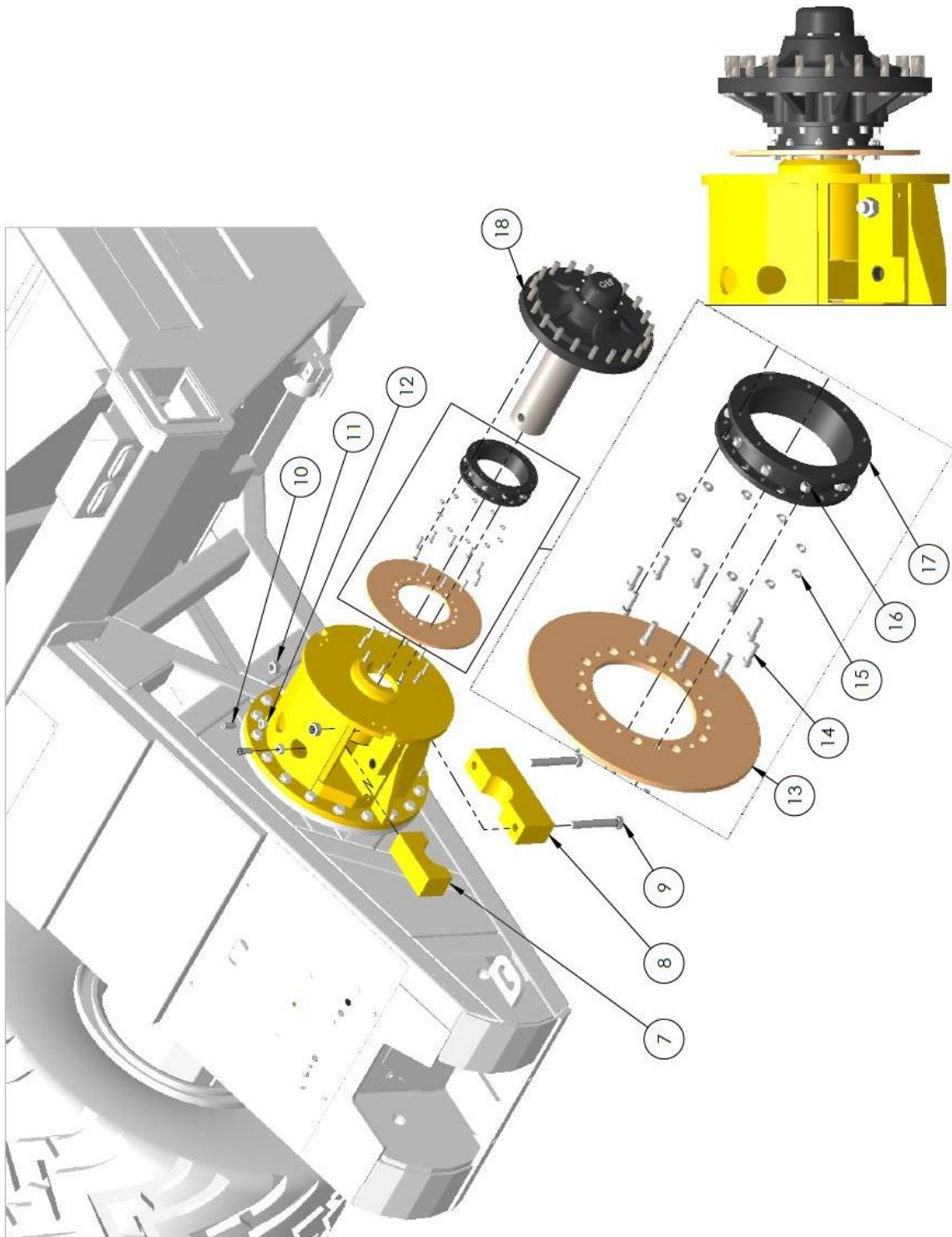

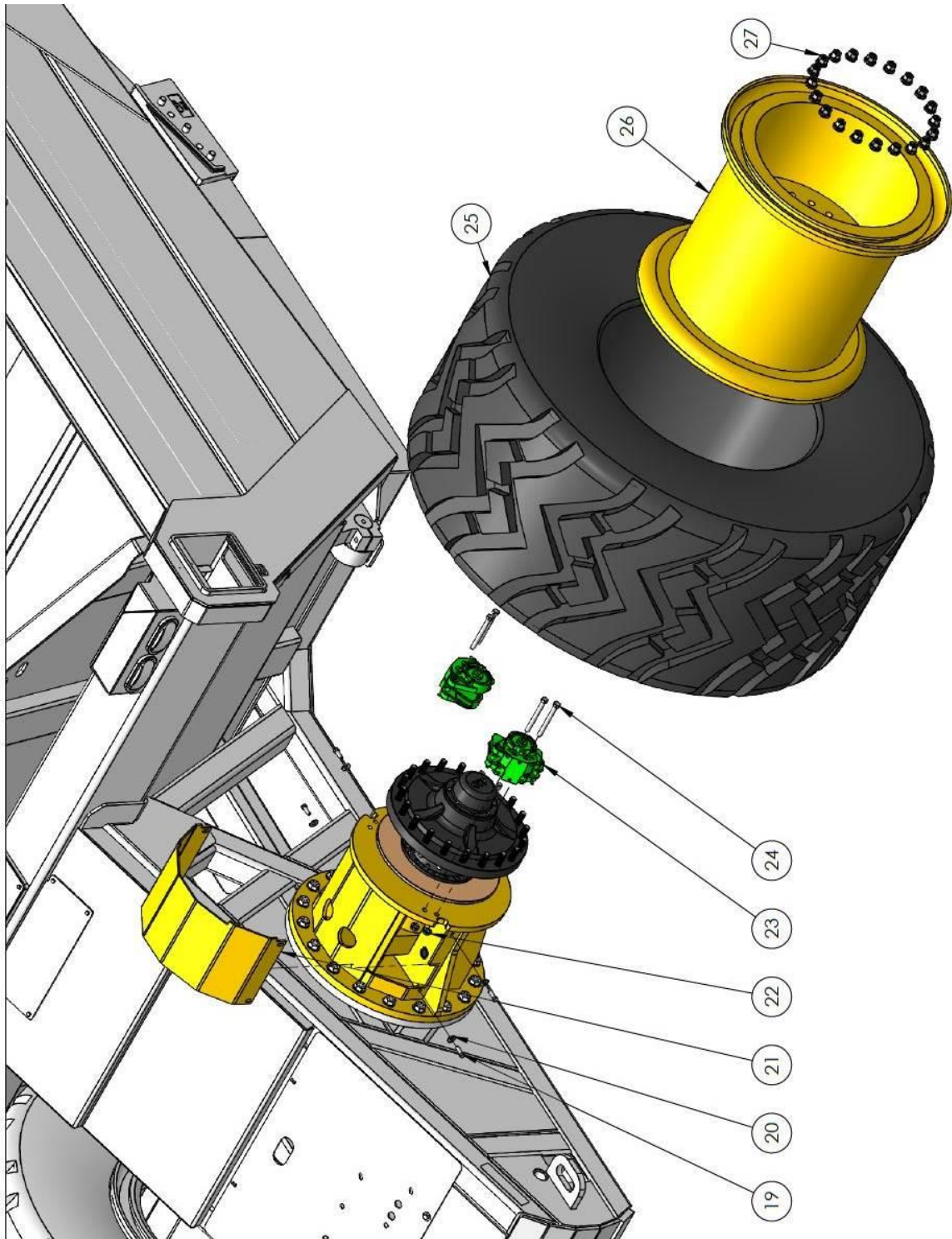

BRIDGEVIEW MANUFACTURING INC.

	Description	ID #	QTY		Description	ID #	QTY
1	Rubber Hose, 1-3/4" x 1-1/4" x 7-3/8"	31355	4	15	Washer, 1/2" High Collar	10183	20
2	Brake Axle Cone	31262	2	16	Stover Lock Nut, 1/2"	20154	20
3	Rubber Hose, 1-3/4" x 1-1/4" x 1"	31355	4	17	Brake Rotor Spacer	31280	2
4	Hardened Flat Washer, 1"	31372	36	18	Hub Assembly	30478	1
5	Bolt, 1" x 2-1/2" UNF Gr. 8 *	30798	36	19	Bolt, 1/2" x 1-1/2"	10174	8
6	Rubber Hose, 1-3/4" x 1-1/4" x 2"	31355	4	20	Flat Washer, 1/2"	11668	8
7	Spindle Brake Clamp A	31259	2	21	Brake Hose Cover Plate	31256	2
8	Spindle Brake Clamp B	31260	2	22	Stover Flange Nut, 5/8" UNF Gr. 8	15398	8
9	Bolt, 1-1/4" x 9" UNF Gr. 8	31112	4	23	Brake Caliper	31221	4
10	Set Screw, 1" x 2-1/2" UNF	30791	4	24	Bolt, 5/8" x 6" UNF Gr. 8	31352	8
11	Stover Lock Nut, 1-1/4" UNF Gr. 8	31113	4	25	875/65R29 Tire	#	2
12	Hex Nut, 1" UNF Gr. 8	30793	4	26	29" x 27" 5 Piece Rim	29010	2
13	1220A Brake Rotor	31278	2	27	Wheel Nuts **	31130	20
14	Socket Head Bolt, 1/2" x 1-3/4" UNF Gr. 8	31353	40				

**** See 3.1 Wheels and Tires for wheel nuts torque**

***Use High Strength Low Temperature Loctite on 1" x 2-1/2" NF Gr. 8 bolt**

NOTE: See local tire dealership for replacement or tires

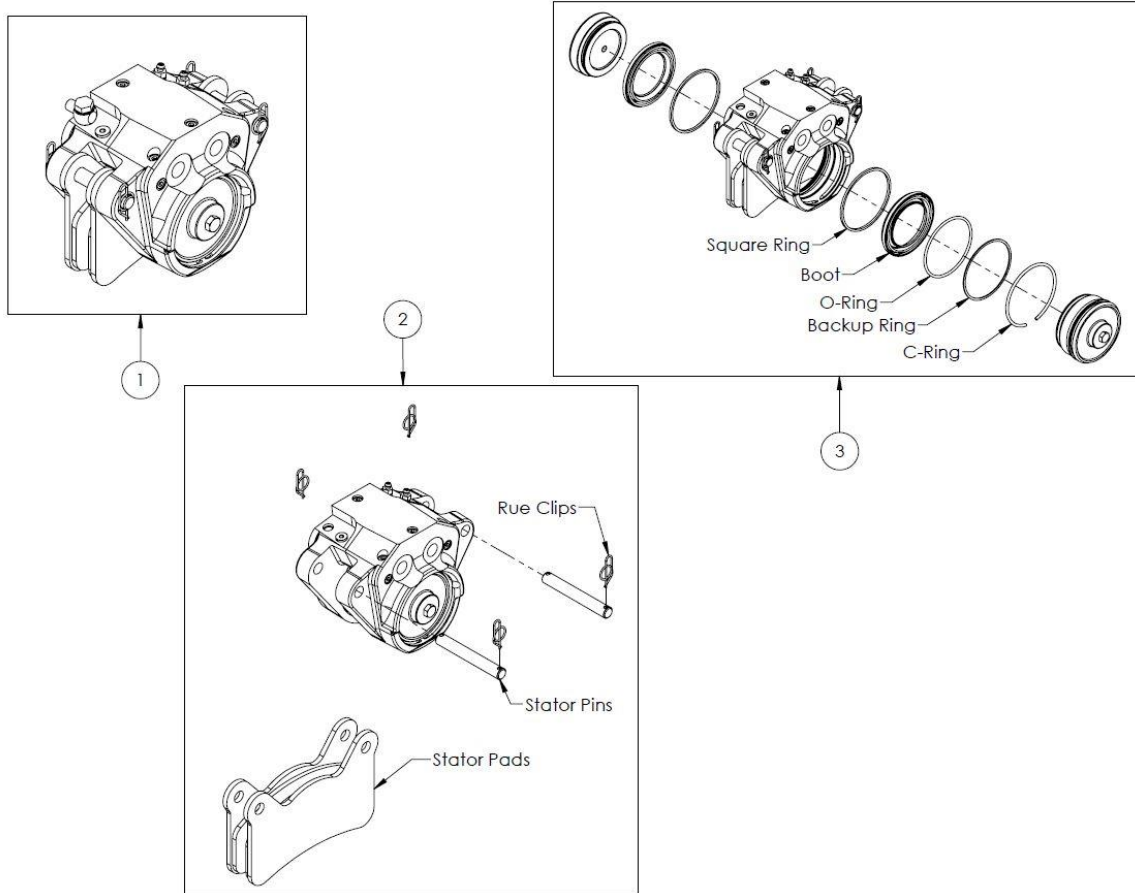

	Description	ID #	QTY
1	Brake Caliper *	31221	4
2	Stator Service Kit: Includes stator pads, stator pins, and rue clips	31546	-
3	Seal Service Kit: Includes piston boots, square rings, O-rings, backup rings, and c-rings	31547	-

* Qty is per machine

2.13.4 Brake Hydraulic Schematic

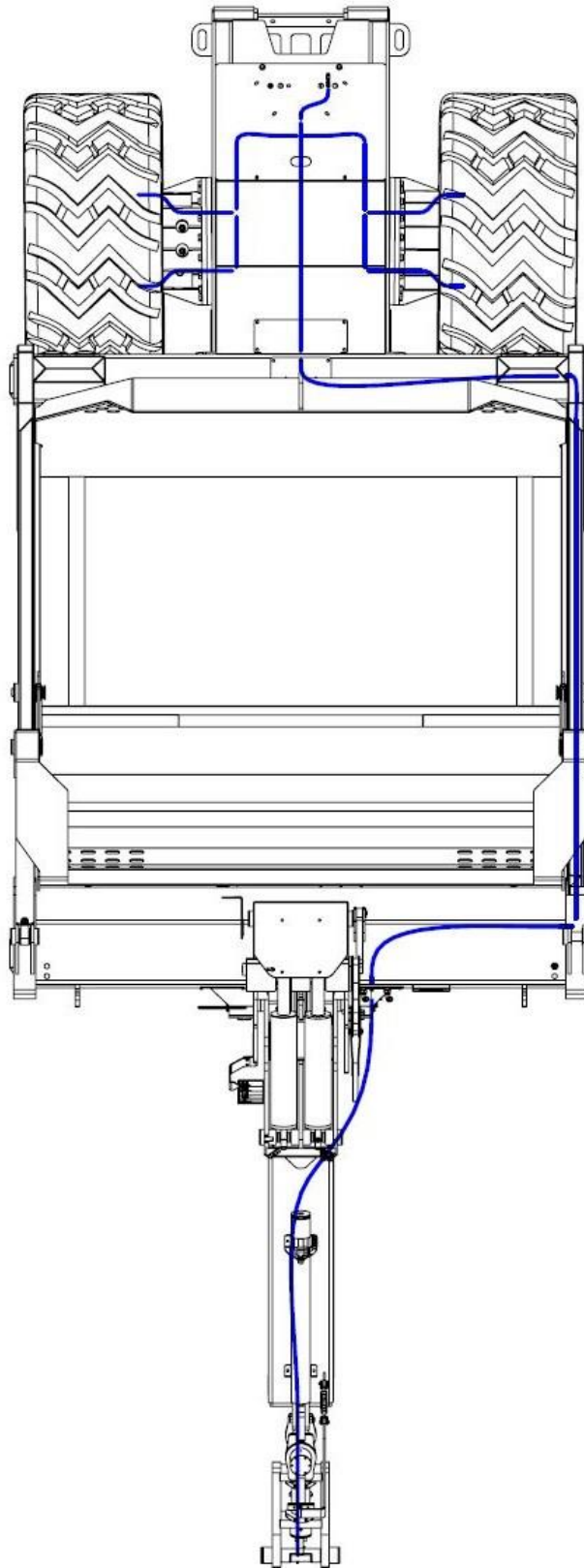

2.14 Optional Tractor Brake Kit

If you are looking for more stopping power the Pulldozer 1220A can be outfitted with a brake kit. If your tractor is not equipped with the trailer brake option the Tractor Brake Kit (31272) will make it possible to connect the scraper hydraulic brake system up. You are to supply your own male pioneer end to install on the hose ends to match your current tractor.

2.14.1 Hook-Up/Operation

1. Connect the specific hydraulic “return” line hose to the tractors case drain port.
This is important in order to provide and speed up pressure relief after brakes are released. Ensure the proper “relief” hose is used here, not to be confused with the other “pressure” supply hose.
2. Connect the “pressure” hose to the tractors auxiliary hydraulic port (remote).
Braking, with this alternate configuration, will involve engaging the respective hydraulic lever in order to “activate” the scrapers brake system in addition to the tractor’s brakes. When releasing brakes, the hydraulic lever must then be returned back into float position.

2.14.2 Setting Pressure Valve/Brake Distance

WARNING: Stop tractor engine, place all control in neutral, set park brake, remove ignition key and wait for all moving parts to stop before servicing, adjusting, repairing or unplugging.

The pressure valve range is typically set around TBA to TBA PSI. This may need to be adjusted to ensure a proper braking balance between the tractor and scraper braking system.

The following is a suggested procedure for adjusting this balance:

1. Test tractor's original braking distance.
 - a. With an empty load in the scraper and driving on a smooth flat road, apply the *only* tractor brakes and take note of the distance required to come to a complete stop.
2. Set pressure valve and connect scraper brakes.
 - a. With an initial valve pressure setting between TBA and TBA, connect the scraper brakes as describe in the previous section.
3. Test loaded trailer braking distance
 - a. With a loaded scraper, test the braking distance again using *both* tractor and scraper brakes. Compare this second distance to the original distance measured in Step 1.
4. Adjusting pressure valve setting.
 - a. If the braking is too fast, it may be applying pressure too quickly to the scraper brakes and could result in premature wear on its components. You may wish to reduce the valve pressure until a comfortable balance is achieved.
 - b. If the braking is too slow, it may be relying to much on the tractor's brakes and you may wish to increase the valve pressure until an acceptable balance is achieved.

2.14.3 Tractor Brake Assembly

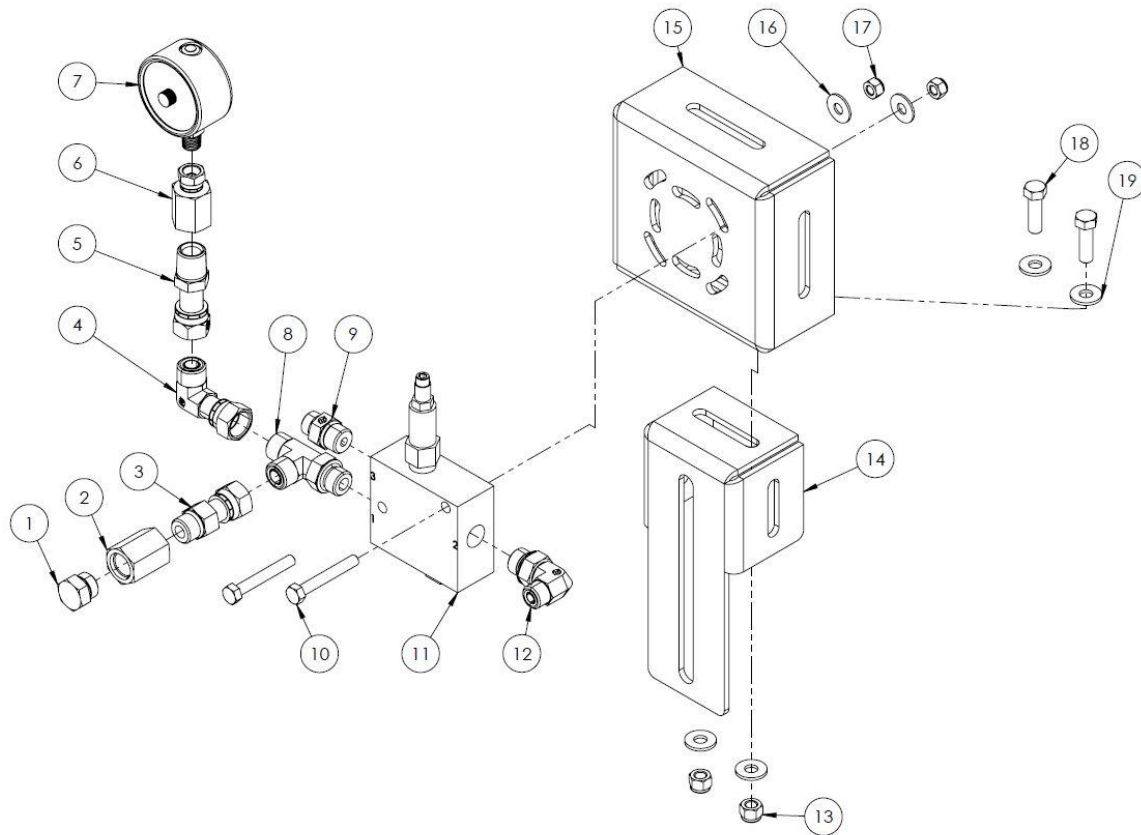

	Description	ID #	QTY		Description	ID #	QTY
1	O-Ring Box Hex Plug	*	1	11	Pressure Reducing Valve	31357	1
2	Fitting, 8FB-8FB	*	1	12	Fitting, 8MORB-6MORFS90	*	1
3	Fitting, 8FORFSX-8MB	*	1	13	Nylon lock nut, 3/8"	10806	2
4	Fitting, 8FORFSX-8MORFS90	*	1	14	Tractor Valve Bracket B	31269	1
5	Fitting, FORFSX-8MP	*	1	15	Tractor Valve Bracket A	31268	1
6	Fitting, 8FP-4FP	*	1	16	Flat washer, 5/16"	12496	2
7	Pressure Gauge	31356	1	17	Nylon lock nut, 5/16"	11815	2
8	Fitting, 8MBR-8MORFS-8MORFS	*	1	18	Bolt, 3/8" x 1-1/4"	10253	2
9	Fitting, 8MORB-6MORFS	*	1	19	Flat washer, 3/8"	11667	4
10	Bolt, 5/16" x 2-1/4"	25541	2				

*** Note: See local hydraulic dealership for replacement fittings**

2.14.4 Tractor Brake Hydraulic Schematic

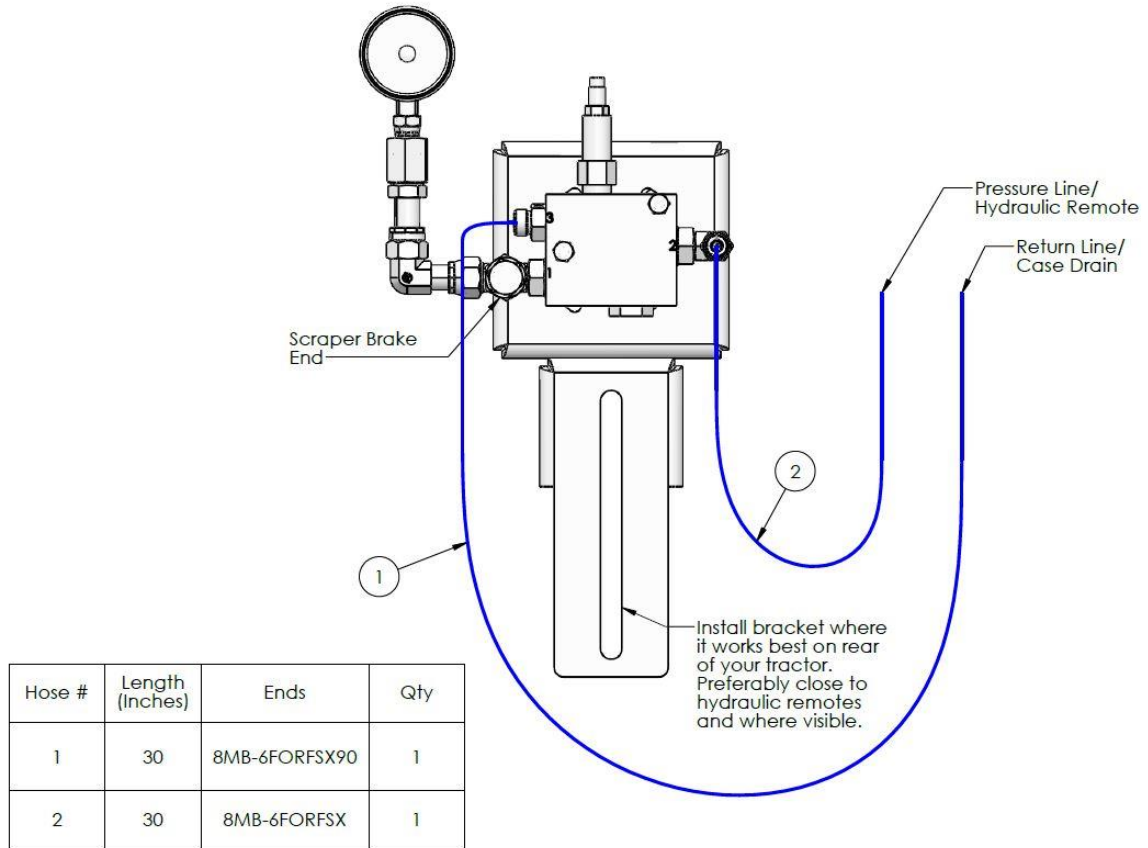

2.15 Specifications

1220A Pulldozer	
Operation	
Scraping Width	11'
Bowl Struck (level with bowl)	14 yards
Bowl Heaped	20 yards
Max Depth of Cut	8"
Transport	
Width	12'
Height	12'
Length	32'
Weight (Total)	28,000 lbs.
Weight (Tongue)	7,200 lbs.
Min Ground Clearance	15"
Tires	
Size	875/65R29
Pressure	80 psi
Wheel Nut Torque	650 ft-lb

3. MAINTENANCE & LUBRICATION

General maintenance of your Pulldozer 1220A scraper should be done on a regular basis. This includes checking all bolts to ensure they are tight, ensuring all joints are properly greased, and that all moving parts are functioning correctly.

Before servicing the machine, block the wheels, shut the tractor off, set the bowl on the ground, and remove the tractor key. If working under the machine, block the machine up for a safe and secure working area.

Before the scraping season, a full inspection of the scraper should be done, ensuring that the wheel hubs are tight and fully greased, any broken blades replaced, and no hydraulic leaks are present.

- After 10 hours of work, all bolts and nuts should be checked and tightened if necessary
- After every 10 hours of work, all grease zerks should be greased
- After 50 hours of work, all bolts should be rechecked and tightened if necessary. Check wheel bearings and adjust if necessary
- After 300 hours of work, clean and repack wheel bearings. If necessary, replace cutting edges, worn pins, worn bushings, etc.

3.1 *Wheel and Tires*

Maintaining proper tire pressure will help to alleviate puncture problems on rough terrain. Check tires for wear and tear on a regular basis.

Tire Size	875/65R29
Tire Pressure	80 psi
Wheel Dry Bolt Torque	650 ft-lb

Warranty does not cover damaged rims and hubs due to loose wheel bolts. The tire manufacturer covers tire warranty. See your local tire dealer for service and replacement.

3.2 Greasing

The Pulldozer 1220A scraper is fitted with a number of grease zerks. It is important that these locations be lubricated as per the maintenance schedule. See the grease decal, on the front of the square tubing beside the serial number, to know where the grease locations are.

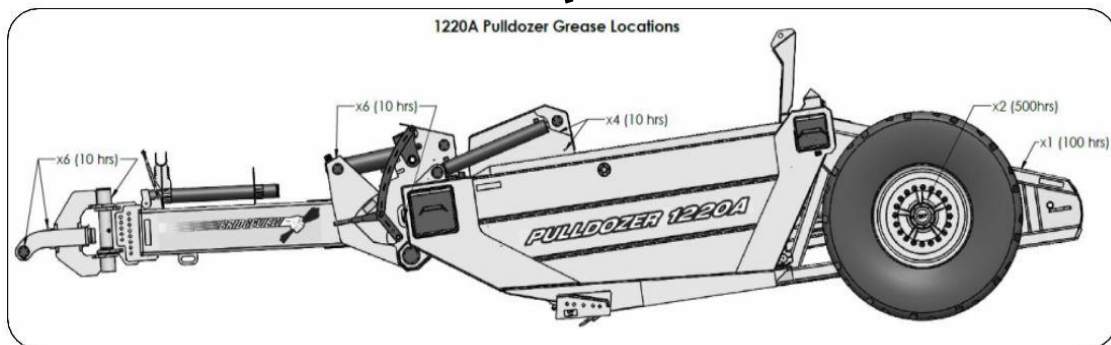
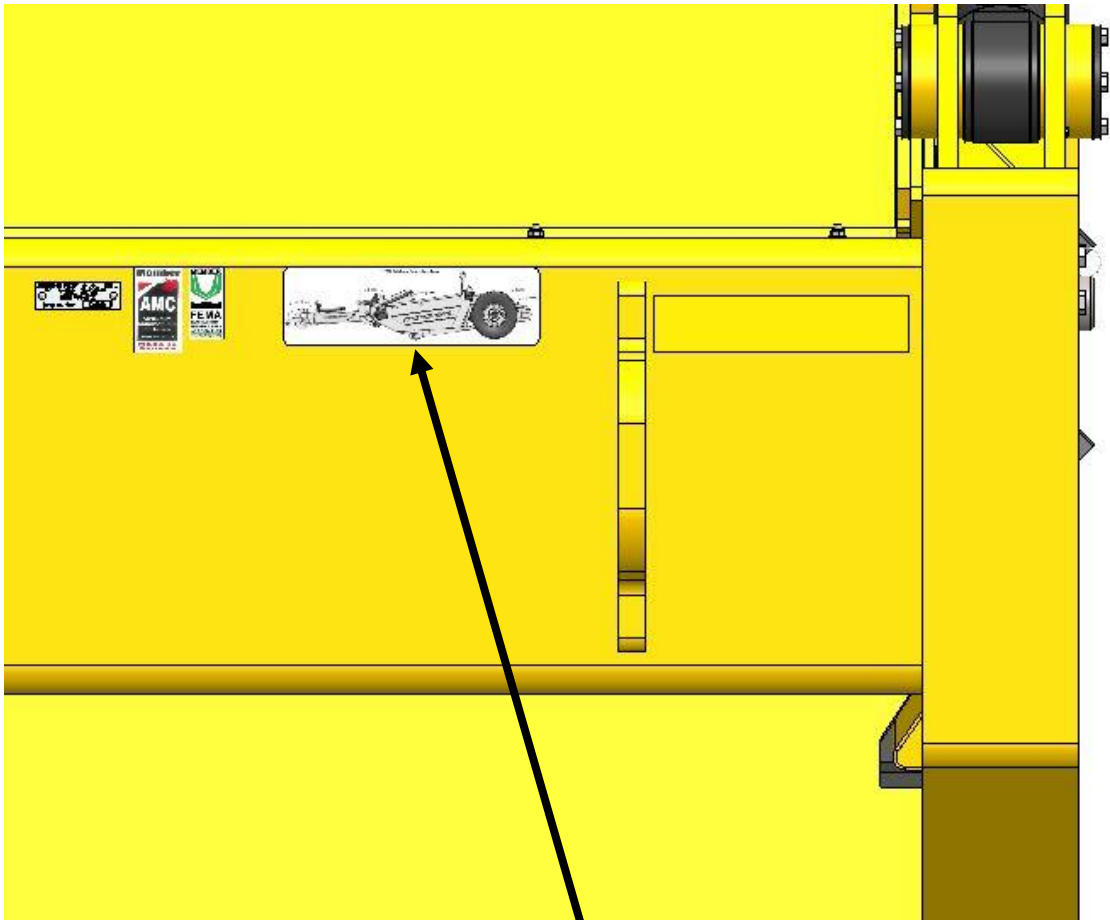

3.3 Cutting Edge Wear

It is very important to keep your machine in optimal working condition, if not your efficiency and productivity drops off substantially. Keeping your blades in working condition decreases the load on the tractor.

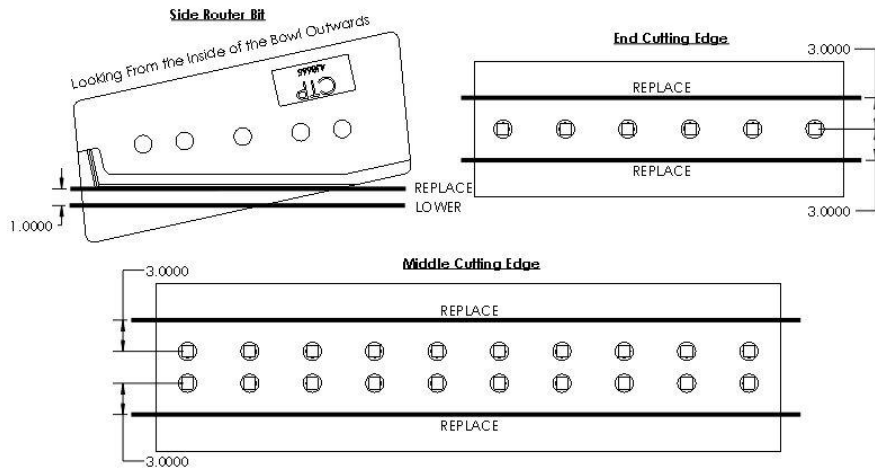

Different types of blades operate better in different conditions. Picking the right blade for the job increases productivity. Straight blades operate better in loose/sandy conditions because there is less force needed to penetrate the material due to the serration. Serrated blades operate better in clay/dirt conditions because it takes less force to penetrate the material. We offer a stinger configuration, as shown below:

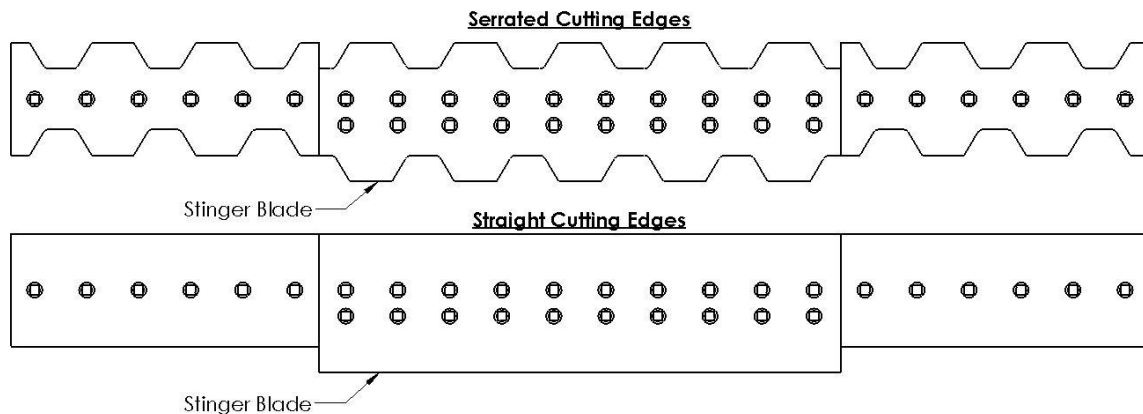

3.4 UHMW Plate/Bar Wear

It is very important to service your abrasion bars/plates (UHMW). Check to see if there is significant wear on them, if so replace. Service them every **100 hours**.

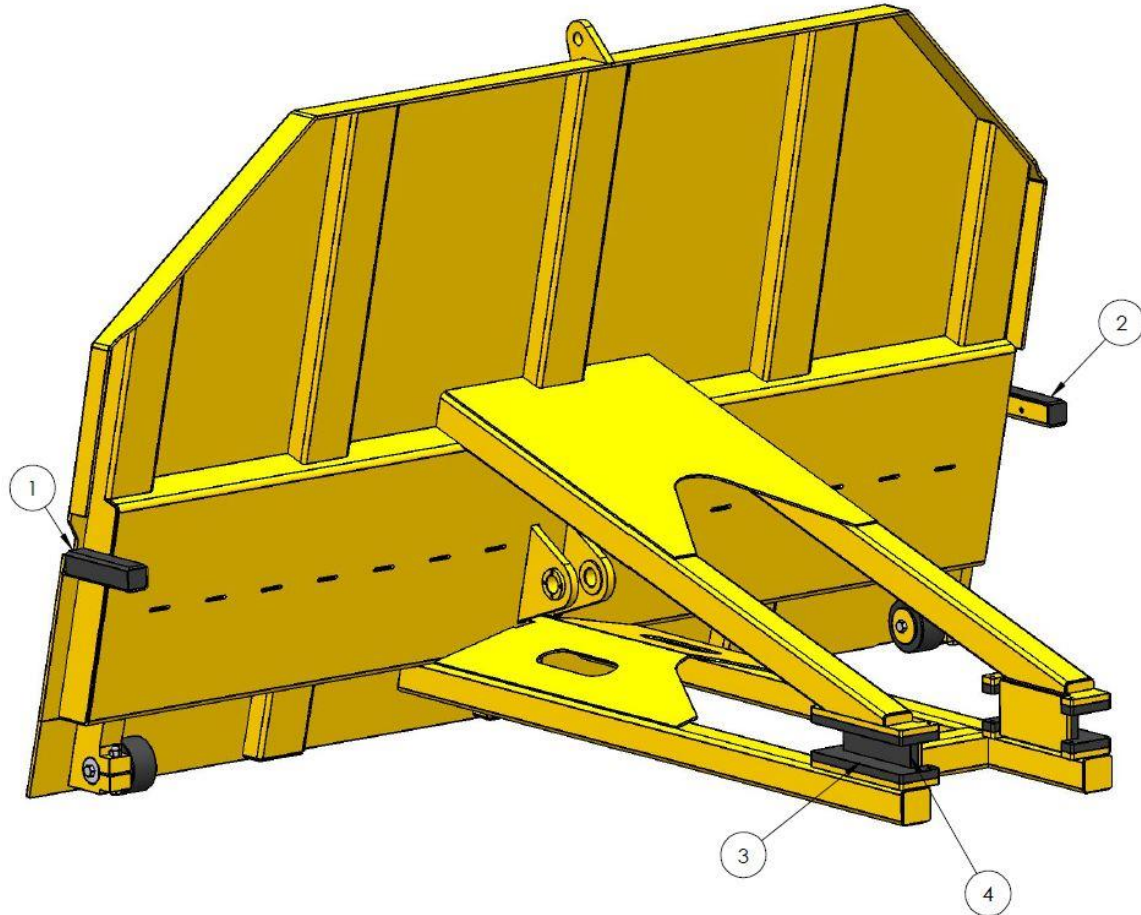

Item #	Description	ID #	Qty
1	Ejector Abrasion Bar (LH)	28263	1
2	Ejector Abrasion Bar (RH)	28262	1
3	Ejector Abrasion Plate C	30627	4
4	Ejector Abrasion Plate B	28265	2

3.5 Replaceable Bushings

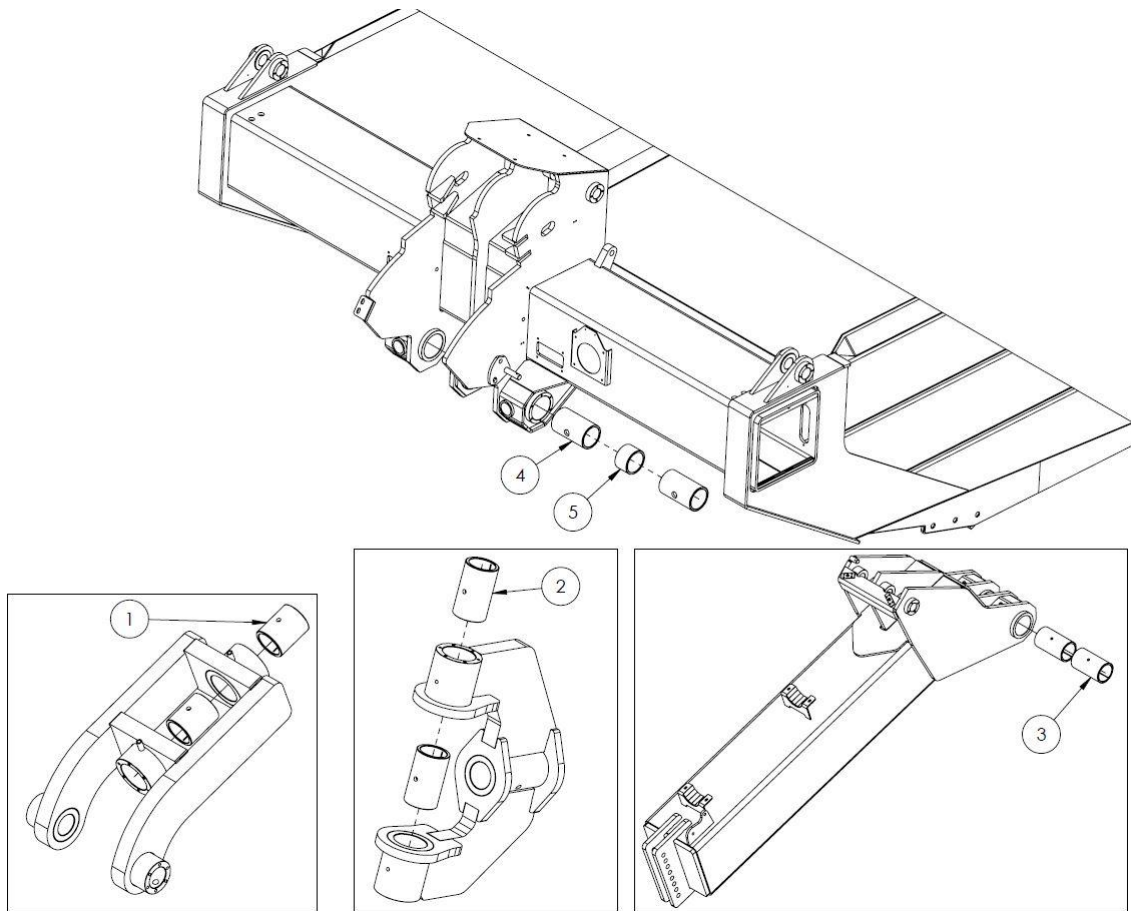

	Description	ID #	QTY		Description	ID #	QTY
1	Hitch Bushing A	30885	2	4	Lift Pivot Bushing A	30670	2
2	Hitch Bushing B	30880	2	5	Lift Pivot Bushing B	30714	1
3	Hitch Bushing C	30843	2				

4 PARTS BOOK

The following diagrams show the part numbers for ordering any replacement parts on a Pulldozer 1220A. Some components may not look exactly as shown.

Quantities are listed for as shown, and some components are optional. The diagrams should be referenced to find the part number, and order quantities should be based on what is required, not necessarily by the quantity on the table.

Left and right as used in the parts book is as viewed from the rear of the scraper looking in the direction of travel.

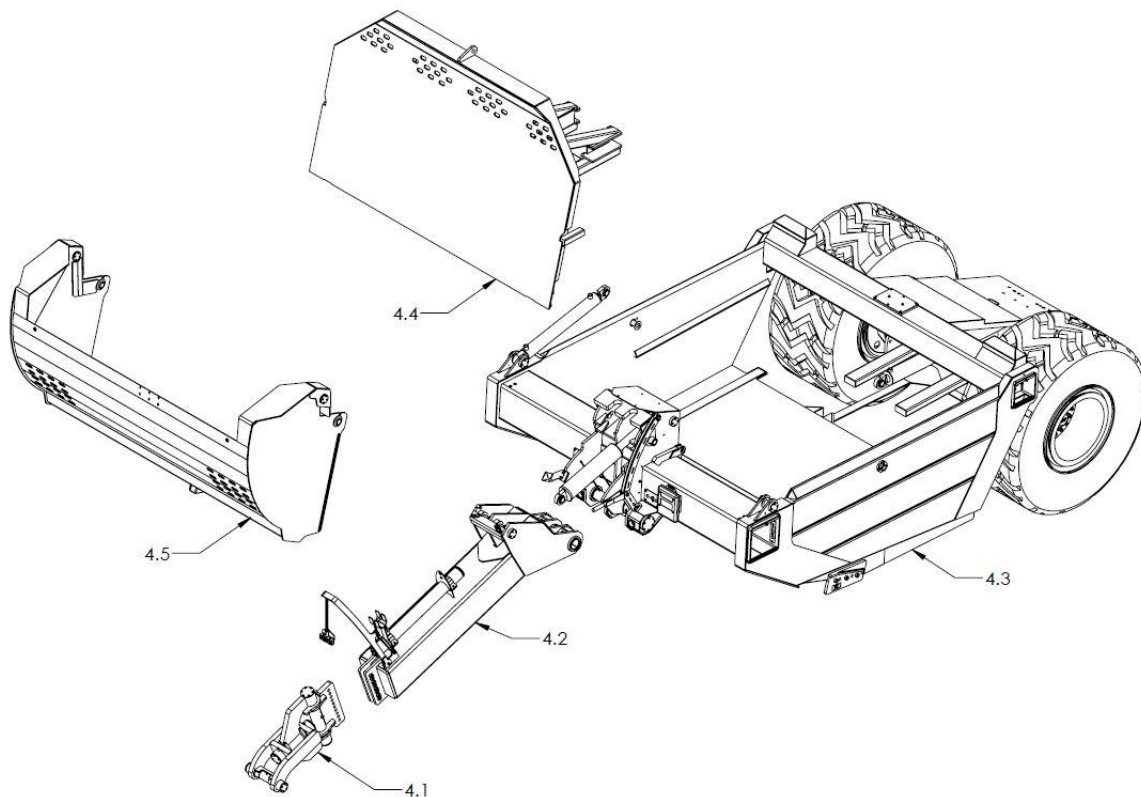

Parts Book Sections	
Section	Description
4.1	Swivel Hitch
4.2	Main Hitch
4.3	20 Yard Bowl
4.4	20 Yard Ejector
4.5	20 Yard Apron

4.1 Swivel Hitch Assembly

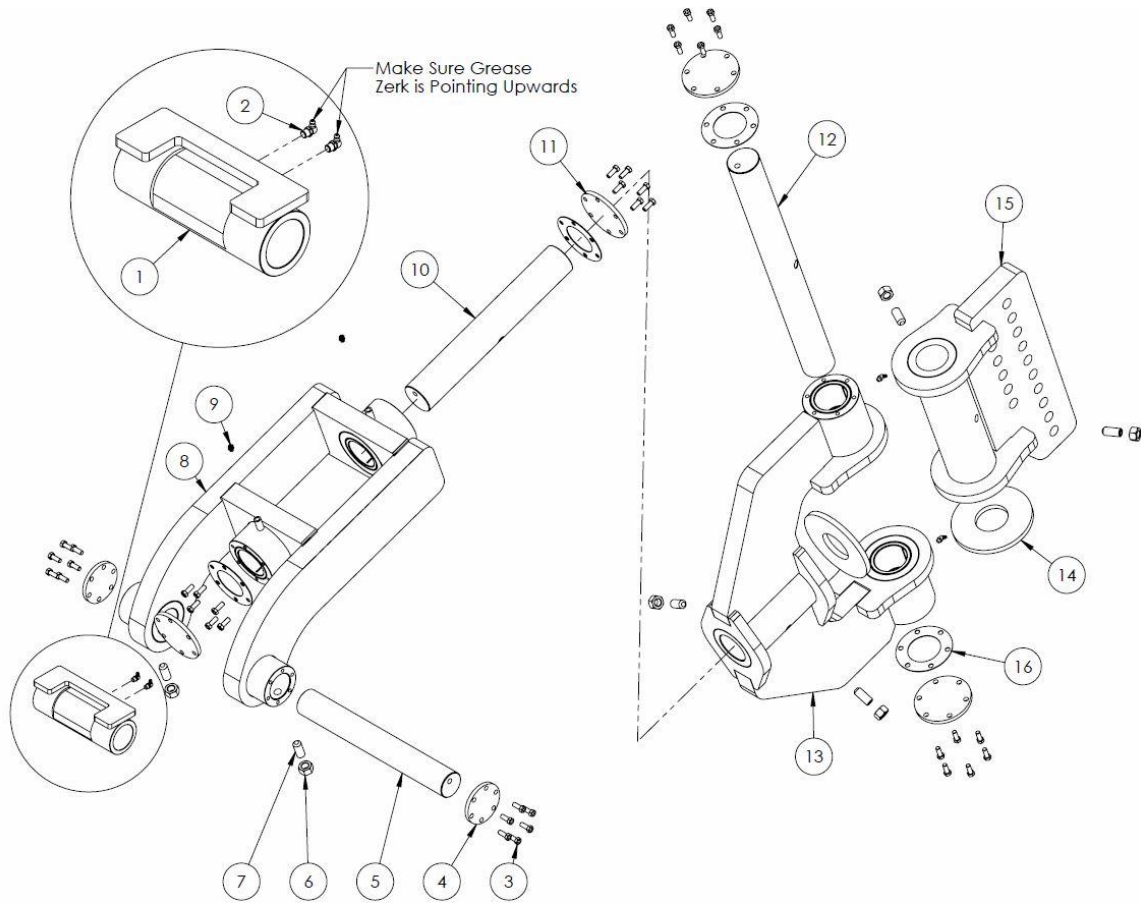

	Description	ID #	QTY		Description	ID #	QTY
1	Bushing Adapter	28334	1	9	Grease Zerk, 1/8" x 45°	15610	4
2	Grease Zerk, 1/4"-28 x 90°	16389	2	10	Middle Swivel Pin	30873	1
3	Bolt, 3/8" x 1" NF Gr. 8 *	30888	36	11	Middle Swivel Pin Cover	30875	4
4	Front Swivel Pin Cover	30872	2	12	Back Swivel Pin	30876	1
5	Front Swivel Pin	30870	1	13	Middle Swivel Scraper Hitch	30855	1
6	Hex Nut, 3/4" NF Gr. 5	24647	6	14	Hitch Washer	30869	2
7	Set Screw, 3/4" x 1-3/4" NF	30887	6	15	Back Swivel Scraper Hitch	31977	1
8	Front Swivel Scraper Hitch	30848	1	16	Swivel Hitch Gasket B	31981	4

***Use High Strength Low Temperature Loctite on 3/8" x 1" NF Gr. 8 bolts**

4.2 Main Hitch Assembly

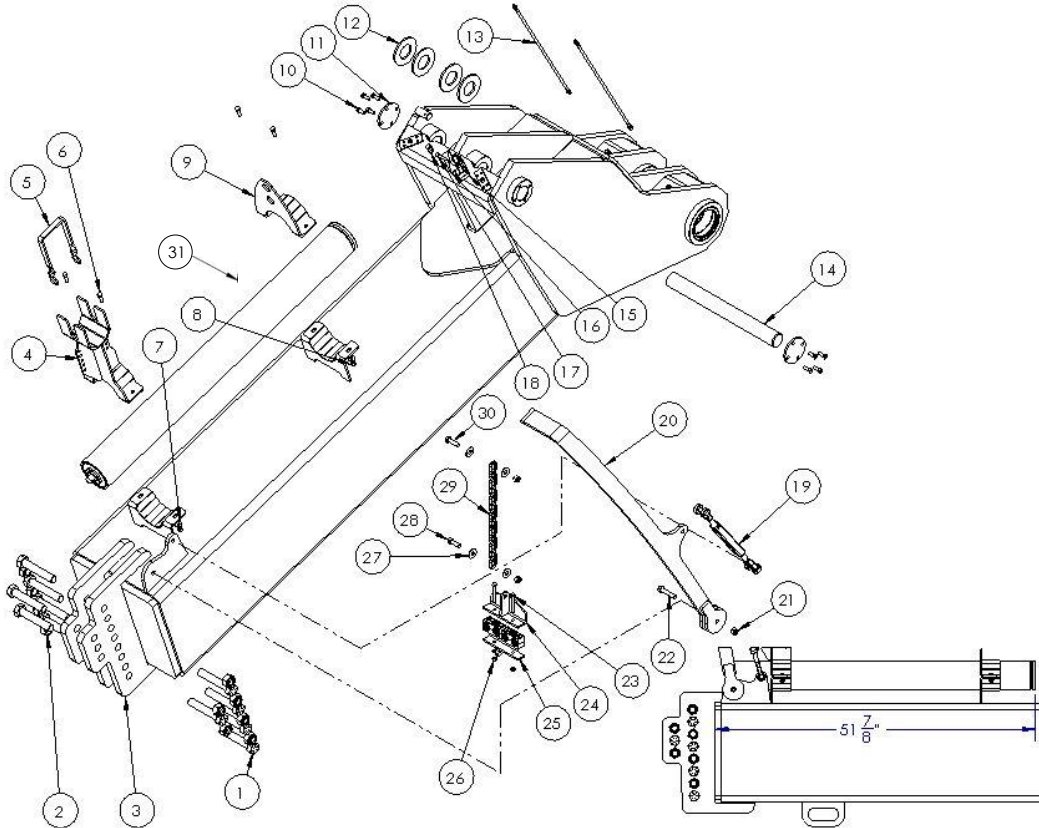

	Description	ID #	QTY		Description	ID #	QTY
1	Bolt, 1" x 5-1/2" NF Gr. 8	30845	11	17	Bolt, 5/16" x 2"	15572	1
2	Stover Lock Nut, 1" NF Gr. 8	21104	11	18	Rubber Insulated Clamp	13629	2
3	Scraper Main Hitch	31972	1	19	Turnbuckle, 5/8" x 6"	14276	1
4	Accumulator Strap	28366	1	20	Hose Holder Arm	34493	1
5	Rubber Strap	28423	1	21	Nylon Lock Nut, 1/2"	10241	3
6	Bolt, 3/8" x 1-1/4"	10253	4	22	Bolt, 1/2" x 2-1/2"	10804	1
7	Flat Washer, 3/8"	11667	4	23	Bolt, 5/16" x 2-3/4"	20909	2
8	Nylon Lock Nut, 3/8"	10806	4	24	Top Plastic Hose Holder	34507	1
9	Rear Accumulator Strap	31123	1	25	Bottom Plastic Hose Holder	34506	1
10	Bolt, 3/8" x 1" NF Gr. 8 *	30888	8	26	Nylon Lock Nut, 5/16"	11815	2
11	Pin Cover F	30882	2	27	Flat Washer, 1/2"	11668	4
12	Plastic Bushing A	28221	4	28	Bolt, 1/2" x 1-1/2"	10174	1
13	Grease Tube, 22" OAL	16829	2	29	5/16" Grade 30 Chain	14554	1
14	Pin D	28222	1	30	Bolt, 1/2" x 1-3/4"	10805	1
15	Twin Hose Clamp	28414	6	31	Accumulator	28419	1
16	Twin Hose Clamp Cover Plate	28413	1	Hitch Shims Required for tight fit on hitch			

See "Hydraulic Cylinders Assembly" for lift cylinder installation

*Use High Strength Low Temperature Loctite on 3/8" x 1" NF Gr. 8 bolts

4.3 Bowl Assembly

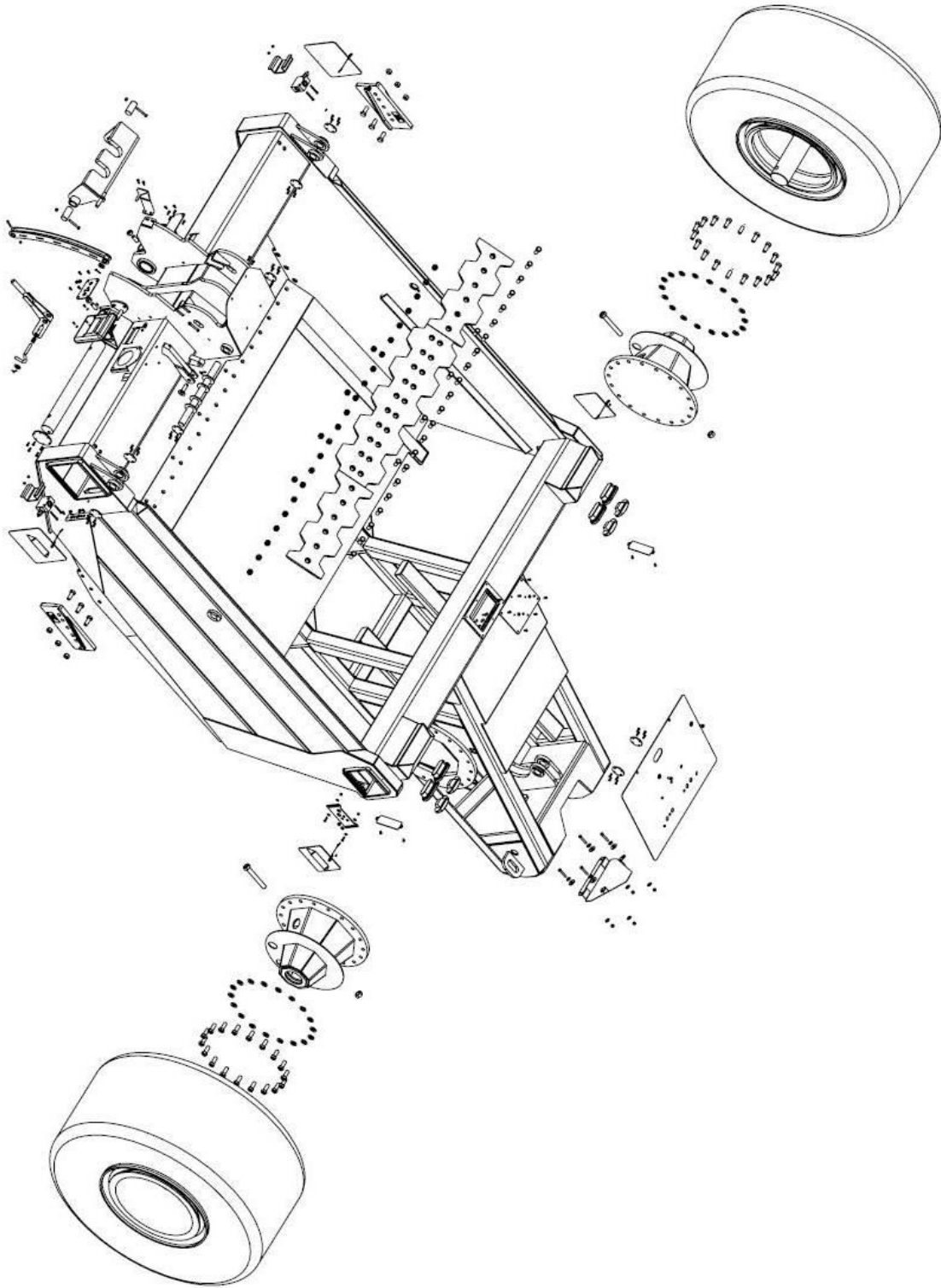

4.3.1 Bowl-Hitch Assembly

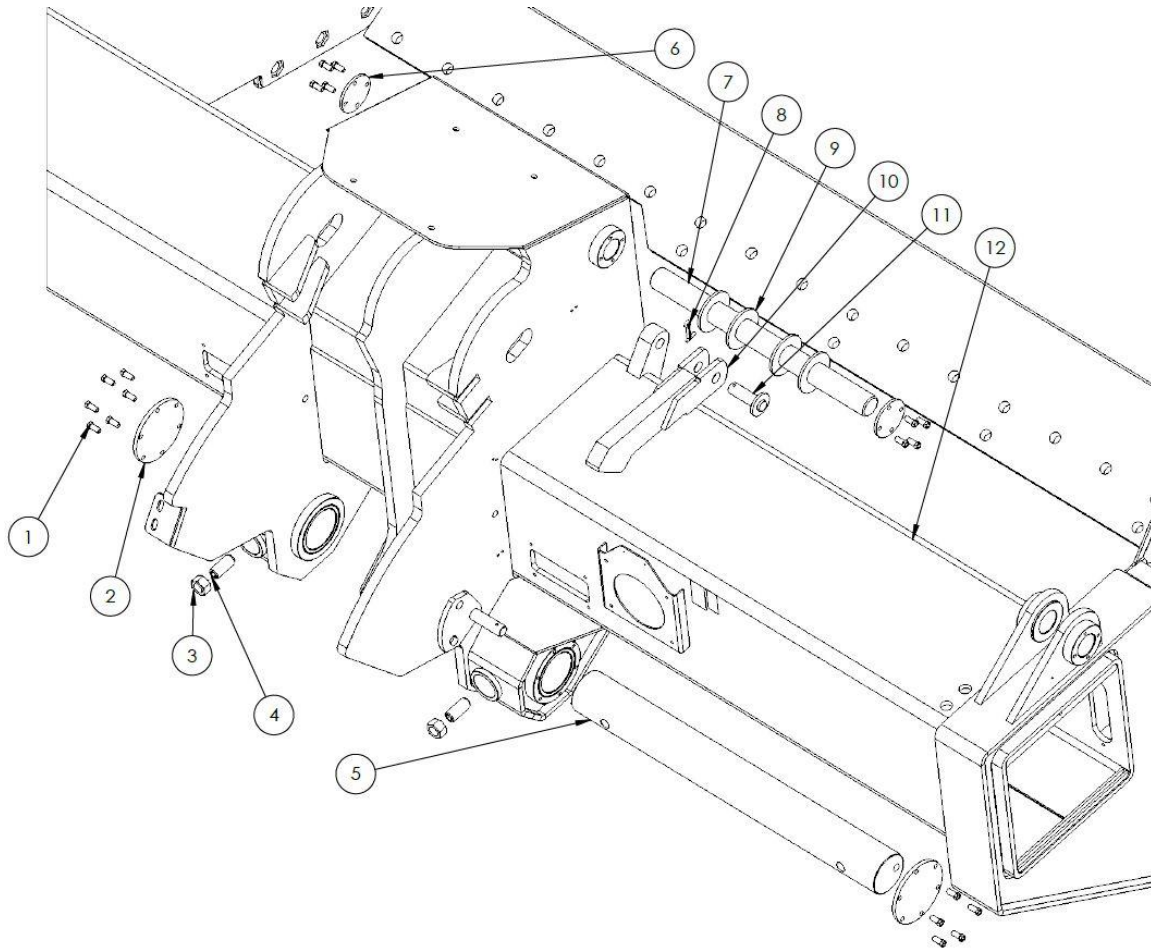

	Description	ID #	QTY		Description	ID #	QTY
1	Bolt, 3/8" x 1" NF Gr. 8 *	30888	20	7	Pin I	30788	1
2	Hitch Rear Pin Cover	30878	2	8	Cotter Pin, 1/4" x 2"	10321	1
3	Hex Nut, 1" NF	30793	2	9	Plastic Bushing A	28221	4
4	Set Screw, 1" x 2-1/2" NF	30791	2	10	Apron Safety Cylinder Stopper	28352	1
5	Hitch Pivot Pin	30879	1	11	Apron Safety Cylinder Stopper Pin	28354	1
6	Pin Cover F	30882	2	12	20 Yard Bowl	30664	1

See "Hydraulic Cylinders Assembly" for lift cylinder installation
 *Use High Strength Low Temperature Loctite on 3/8" x 1" NF Gr. 8 bolts

4.3.2 Front Bowl Components (S/N PD1268 & Down)

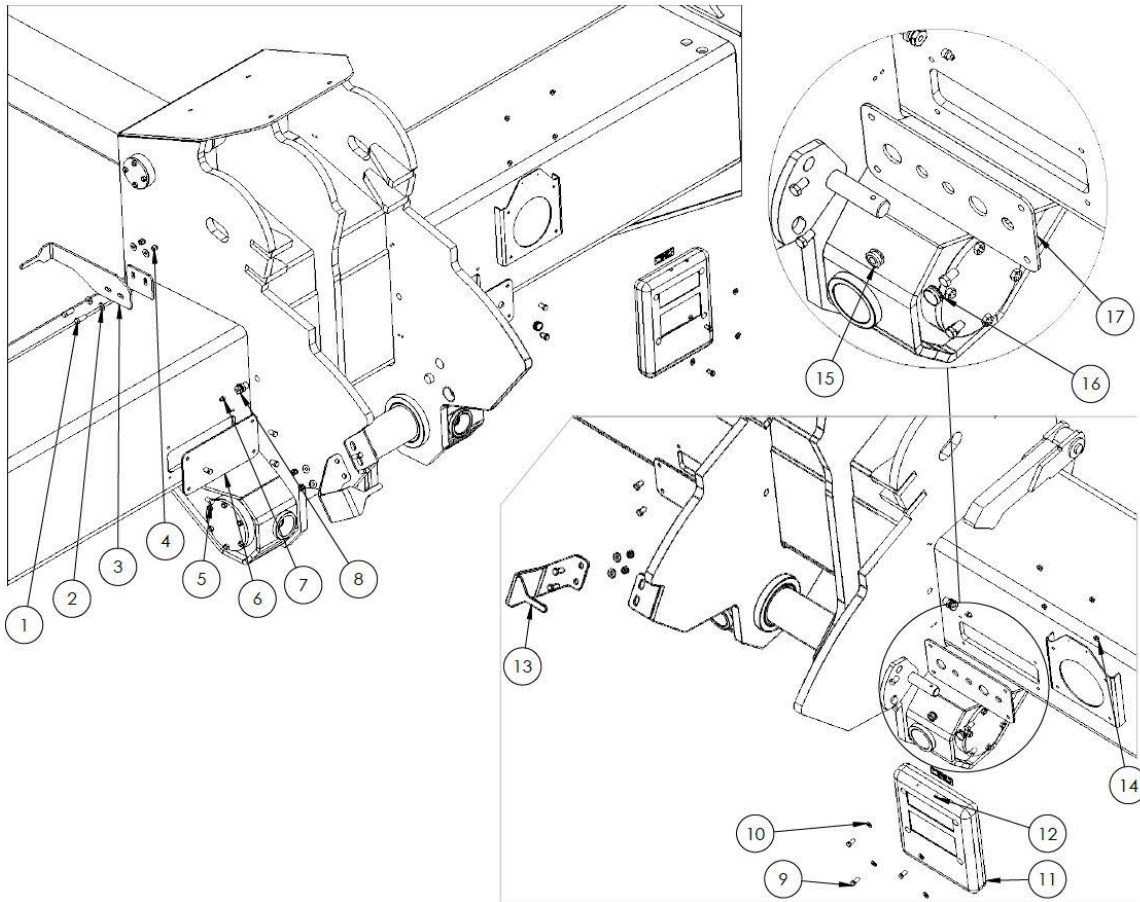

	Description	ID #	QTY		Description	ID #	QTY
1	Bolt, 3/8" x 1-1/4"	10253	4	10	Flat Washer, 1/4"	11666	4
2	Flat Washer, 3/8"	11667	6	11	Operators Manual Holder	22409	1
3	Apron height Indicator Needle	30918	1	12	Pop Rivet, 1/2"-5/8" Grip Range	27192	2
4	Nylon Lock Nut, 3/8"	10806	4	13	Height Indicator Needle	30769	1
5	Bolt, 3/8" x 3/4"	11816	8	14	Serrated Flange Nut, 1/4"	11812	4
6	Pup Scraper Bulkhead Plate	30781	1	15	Rubber Grommet	21428	1
7	Grease Zerk, 1/8" NPT	10270	2	16	Diaphragm Grommet	30796	2
8	Grease Bulkhead	16830	2	17	Front Hydraulic Bulkhead Plate B	31180	1
9	Bolt, 1/4" x 3/4"	11809	4				

See "Hydraulic Cylinders Assembly" for lift cylinder installation

4.3.3 Front Bowl Components (S/N PD1269 & Up)

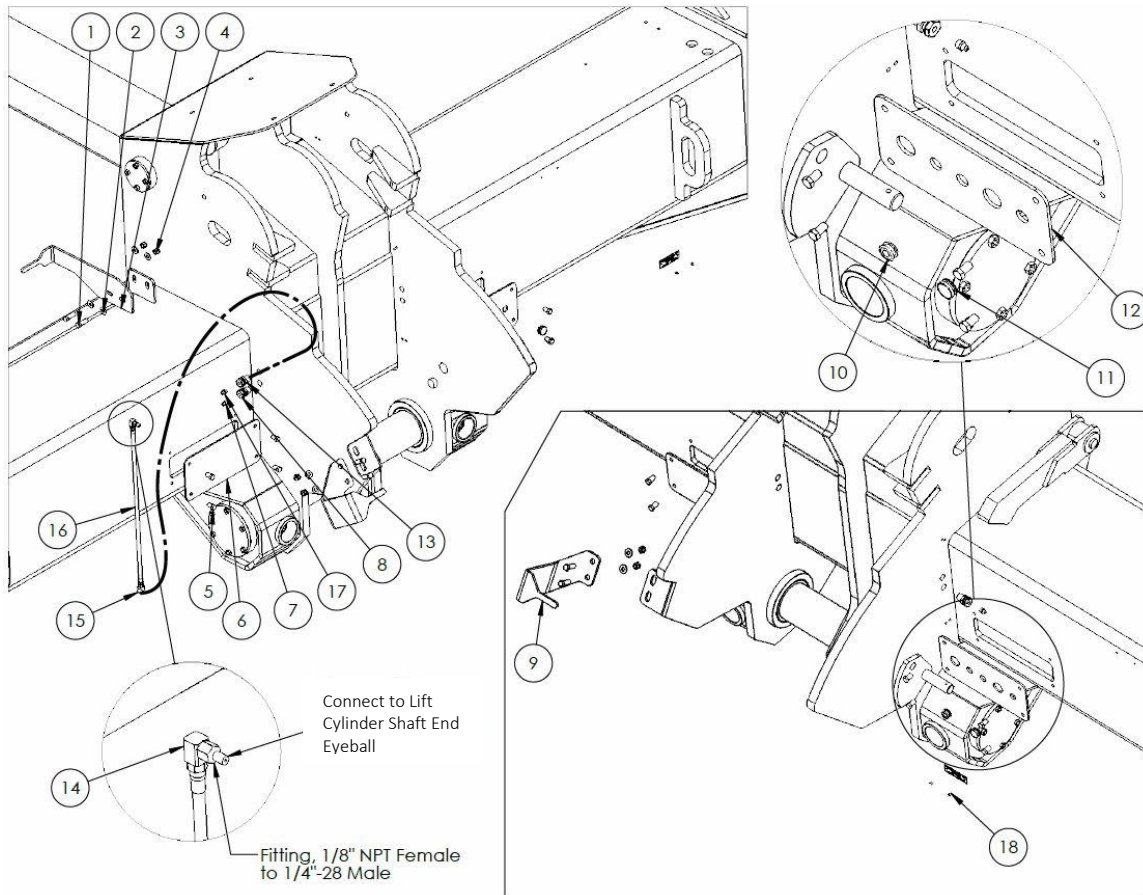

	Description	ID #	QTY		Description	ID #	QTY
1	Bolt, 3/8" x 1-1/4"	10253	4	10	Rubber Grommet	21428	1
2	Flat Washer, 3/8"	11667	6	11	Diaphragm Grommet	30796	2
3	Apron height Indicator Needle	30918	1	12	Front Hydraulic Bulkhead Plate B	31180	1
4	Nylon Lock Nut, 3/8"	10806	4	13	Grease Bulkhead	16830	2
5	Bolt, 3/8" x 3/4"	11816	8	14	90° Street Elbow, 1/8" NPT	31251	2
6	Pup Scraper Bulkhead Plate	30781	1	15	45° Street Elbow, 1/8" NPT	31252	2
7	Grease Zerk, 1/8" NPT	10270	2	16	Grease Tube, 34" OAL	30094	2
8	Grease Bulkhead	16830	2	17	Grease Zerk, 1/8" NPT	10270	2
9	Height Indicator Needle	30769	1	18	Pop Rivet, 1/2"-5/8" Grip Range	27192	2

See "Hydraulic Cylinders Assembly" for lift cylinder installation

4.3.4 Lift Cylinder Safety Lock

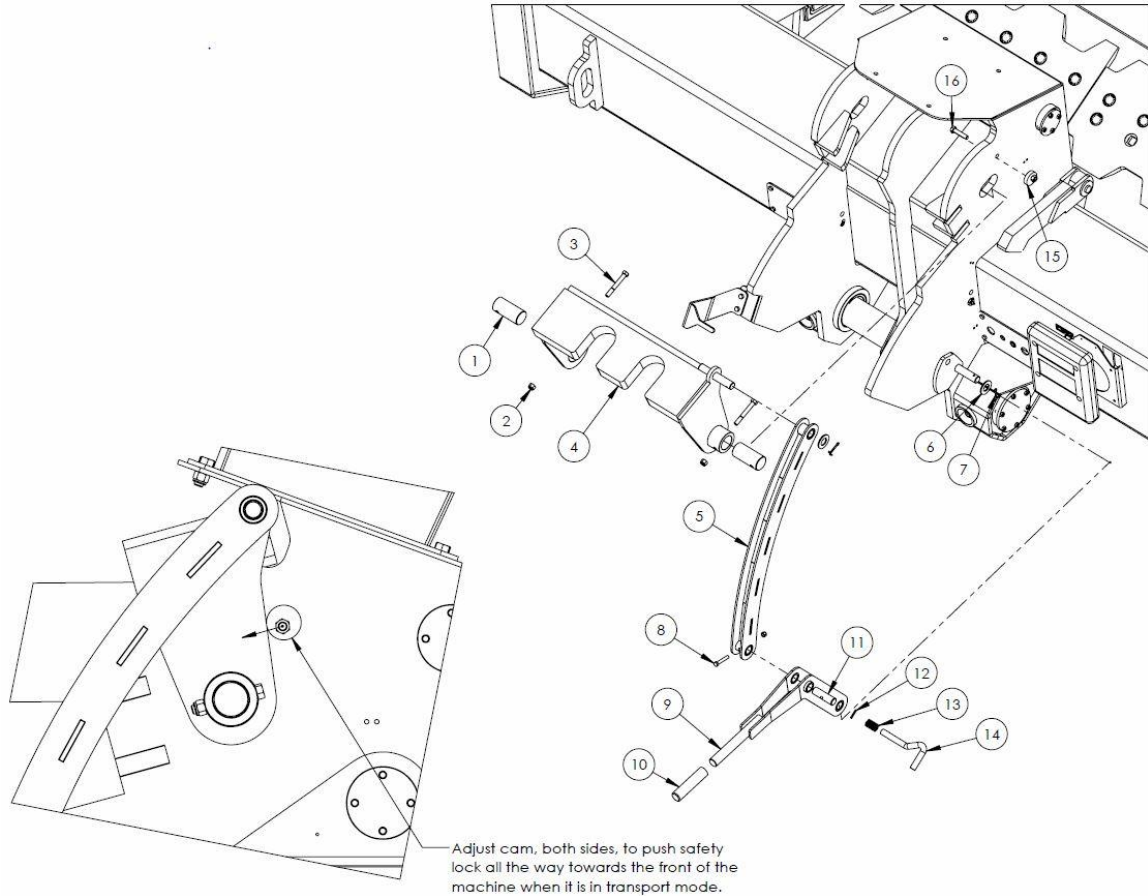

	Description	ID #	QTY		Description	ID #	QTY
1	Lift Cylinder Safety Lock Pin	30636	2	10	Rubber Handle	17587	1
2	Nylon Lock Nut, 1/2"	10241	2	11	Safety Lock Link Pin	30653	1
3	Bolt, 1/2" x 3-3/4"	11782	2	12	Roll Pin, 3/16" x 1-1/4" Plated	10302	1
4	Lift Cylinder Safety Lock	30629	1	13	Spring	10301	1
5	Lift Cylinder Safety Lock Link	30638	1	14	S Handle Pin	22187	1
6	Flat Washer, 1"	14472	2	15	Lift Cylinder Safety Lock Adjustment Plate *	31572	2
7	Cotter Pin, 3/16" x 1-1/2"	10072	2				
8	Bolt, 3/8" x 2-1/4"	13769	1	16	Bolt, 1/2" x 2-1/4" *	11820	2
9	Lift Cylinder Safety Lock Handle	30644	1				

*** For serial numbers PD1269 & Up**

4.3.5 Tube Cover Assembly (S/N PD1268 & Down)

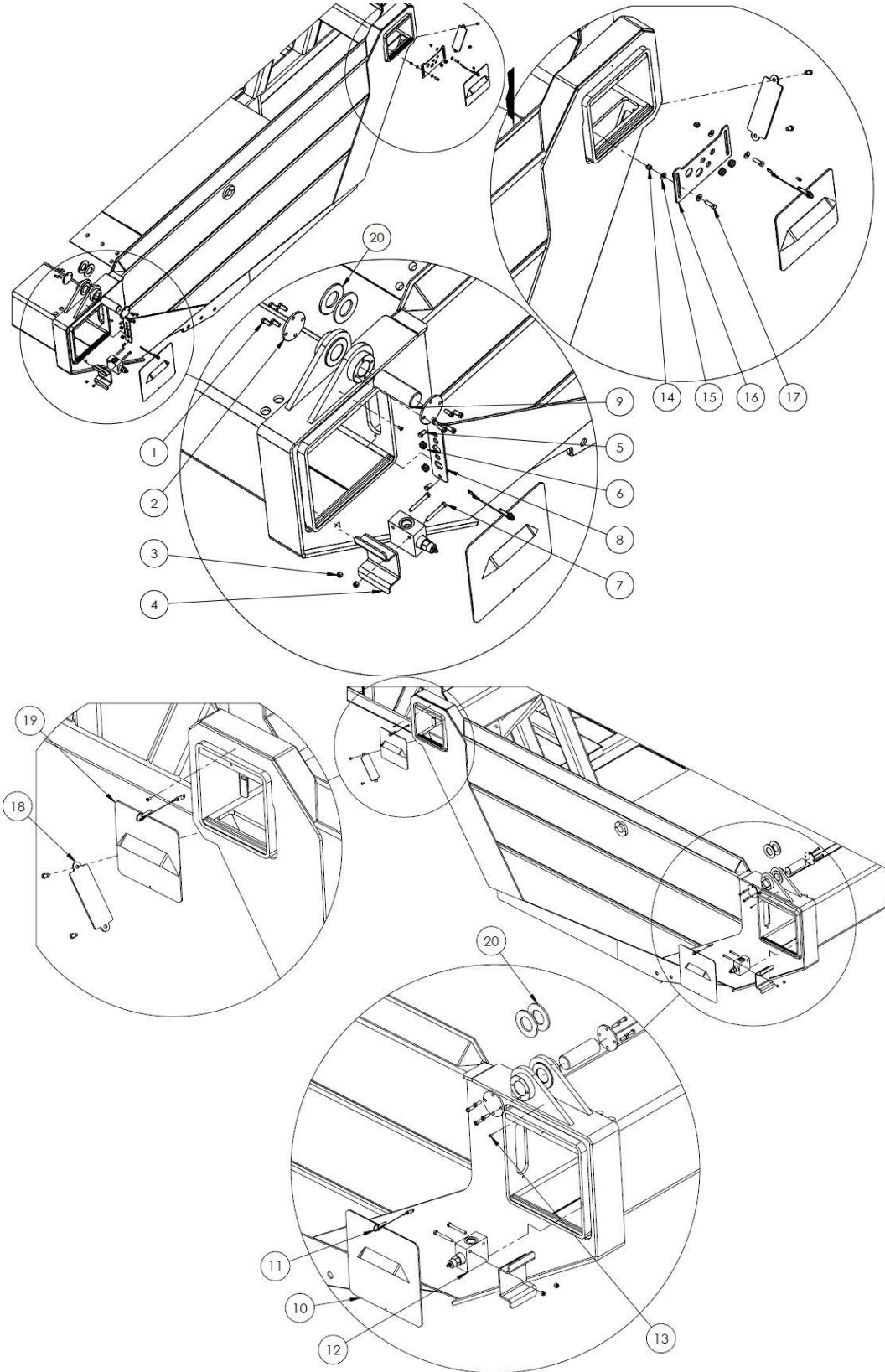

BRIDGEVIEW MANUFACTURING INC.

	Description	ID #	QTY		Description	ID #	QTY
1	Bolt, 3/8" x 1" NF Gr. 8 *	30888	16	10	Front Tube Cover	28358	2
2	Pin Cover G	30884	2	11	Quick Release Pin with Lanyard	28422	4
3	Nylon Lock Nut, 3/8"	10806	4				
4	Valve Block Bracket	28332	2	12	Sequence Valve with Block	28420	2
5	Bolt, 3/8" x 3/4"	11816	2	13	Screw, #10-24 x 1/2"	17035	4
6	Grommet	21428	4	14	Nylon Lock Nut, 3/8	10806	2
7	Bolt, 3/8" x 3-1/4"	23325	4	15	Flat Washer, 3/8"	11667	4
8	Pup Scraper Bulkhead D (S/N PD1268 & Down)	31179	1	16	Pup Scraper Bulkhead A	30779	1
				17	Bolt, 3/8" x 1-1/4"	10253	2
f8	Pup Scraper Bulkhead E (S/N PD1269 & Up)	31340	1	18	Rear Hose Access Cover	30774	2
				19	Rear Side Tube Cover	28360	2
9	Pin F	28233	2	20	Plastic Bushing A	28221	4

See "Hydraulic Cylinders Assembly" for apron cylinder installation
***Use High Strength Low Temperature Loctite on 3/8" x 1" NF Gr. 8 bolts**

4.3.6 Tube Cover Assembly (S/N PD1269 & Up)

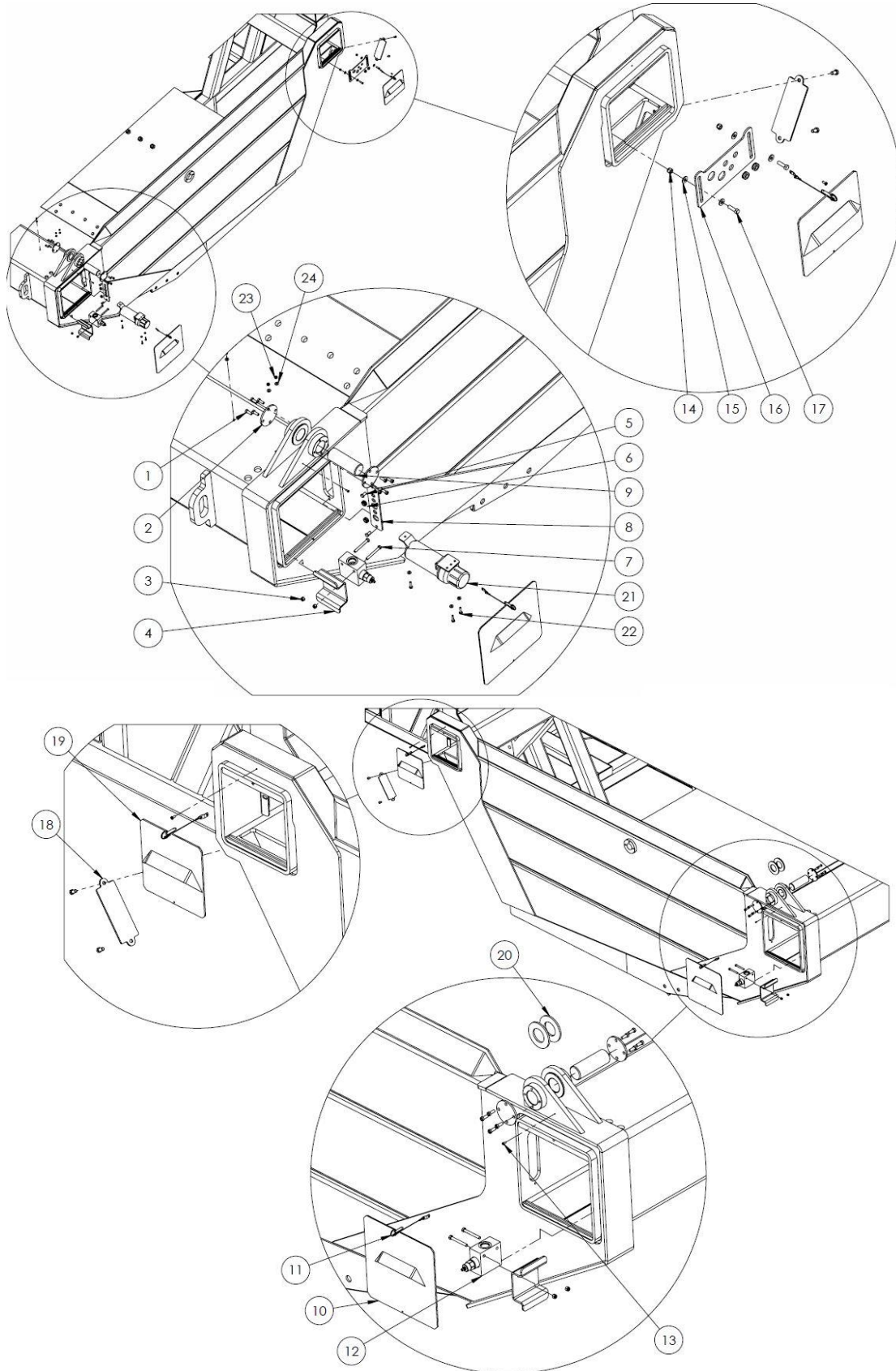

	Description	ID #	QTY		Description	ID #	QTY
1	Bolt, 3/8" x 1" NF Gr. 8 *	30888	16	12	Sequence Valve with Block	28420	2
2	Pin Cover G	30884	2	13	Screw, #10-24 x 1/2"	17035	4
3	Nylon Lock Nut, 3/8"	10806	4	14	Nylon Lock Nut, 3/8	10806	2
4	Valve Block Bracket	28332	2	15	Flat Washer, 3/8"	11667	4
5	Bolt, 3/8" x 3/4"	11816	2	16	Pup Scraper Bulkhead A	30779	1
6	Grommet	21428	4	17	Bolt, 3/8" x 1-1/4"	10253	2
7	Bolt, 3/8" x 3-1/4"	23325	4	18	Rear Hose Access Cover	30774	2
8	Pup Scraper Bulkhead D (S/N PD1268 & Down)	31179	1	19	Rear Side Tube Cover	28360	2
				20	Plastic Bushing A	28221	4
f8	Pup Scraper Bulkhead E (S/N PD1269 & Up)	31340	1	21	Document/Operators Manual Holder (Round)	31946	1
9	Pin F	28233	2	22	Bolt, 1/4" x 1-1/4"	12375	3
10	Front Tube Cover	28358	2	23	Nylon lock nut, 1/4"	11664	3
11	Quick Release Pin with Lanyard	28422	4	24	Flat washer, 1/4"	11666	6

See "Hydraulic Cylinders Assembly" for apron cylinder installation

*Use High Strength Low Temperature Loctite on 3/8" x 1" NF Gr. 8 bolts

4.3.7 Cutting Edges

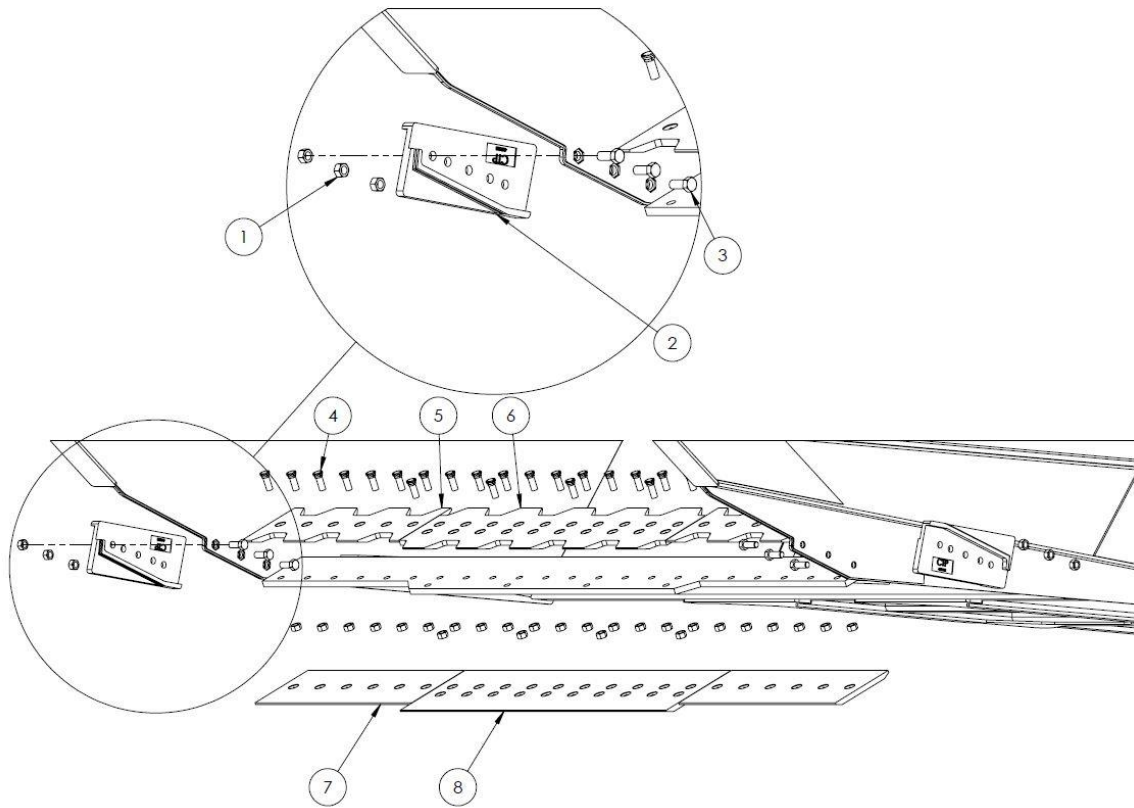

	Description	ID #	QTY		Description	ID #	QTY
1	Plow Hex Nut, 1"	28409	32	5	Serrated End Cutting Edge (Std)	29815	2
2	Side Router Bit	28407	2	6	Serrated Center Cutting Edge (Std)	29814	1
3	Bolt, 1" x 2-1/2" Gr. 8	28773	6	7	Straight End Cutting Edge (Option)	28405	2
4	Plow Bolt, 1" x 2-1/2"	28408	26	8	Straight Center Cutting Edge (Option)	28406	1

4.3.8 Rear Components Assembly (S/N PD1268 & Down)

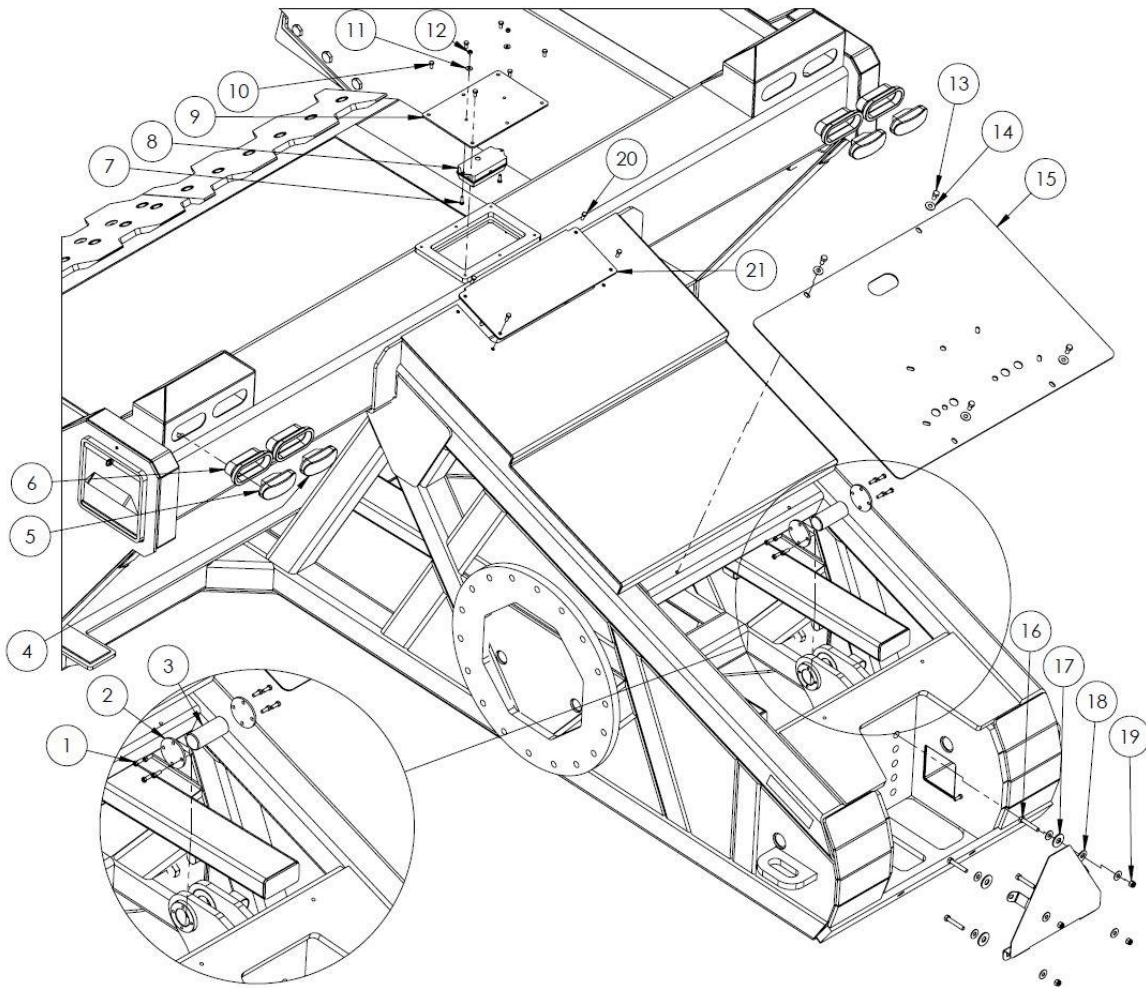

	Description	ID #	QTY		Description	ID #	QTY
1	Bolt, 3/8" x 1" NF Gr. 8 *	30888	8	12	Nylon Lock Nut, 5/16"	11815	2
2	Pin Cover G	30884	2	13	Bolt, 1/2" x 1"	10824	4
3	Pin E	28232	1	14	Flat Washer, 1/2"	11668	12
4	Red Oval LED Light	21721	2	15	Ejector Access Panel	31336	1
5	Amber Oval LED Light	21722	2	16	Bolt, 1/2" x 3"	10321	4
6	LED Light Grommet	21723	4	17	Flat Washer, 3/4"	13717	4
7	Bolt, 5/16" x 1"	20906	2	18	Bolt-On SMV Bracket	30772	1
8	Junction Box	13668	1	19	Nylon Lock Nut, 1/2"	10241	4
9	Rear Top Tube Cover	30787	1	20	Bolt, 3/8" x 1"	13806	4
10	Bolt, 3/8" x 3/4"	11816	6	21	Rear Square Tube Access Plate	31336	1
11	Flat Washer, 5/16"	12496	2				

See "Hydraulic Cylinders Assembly" for ejector cylinder installation
 *Use High Strength Low Temperature Loctite on 3/8" x 1" NF Gr. 8

4.3.9 Rear Components Assembly (S/N PD1269 & Up)

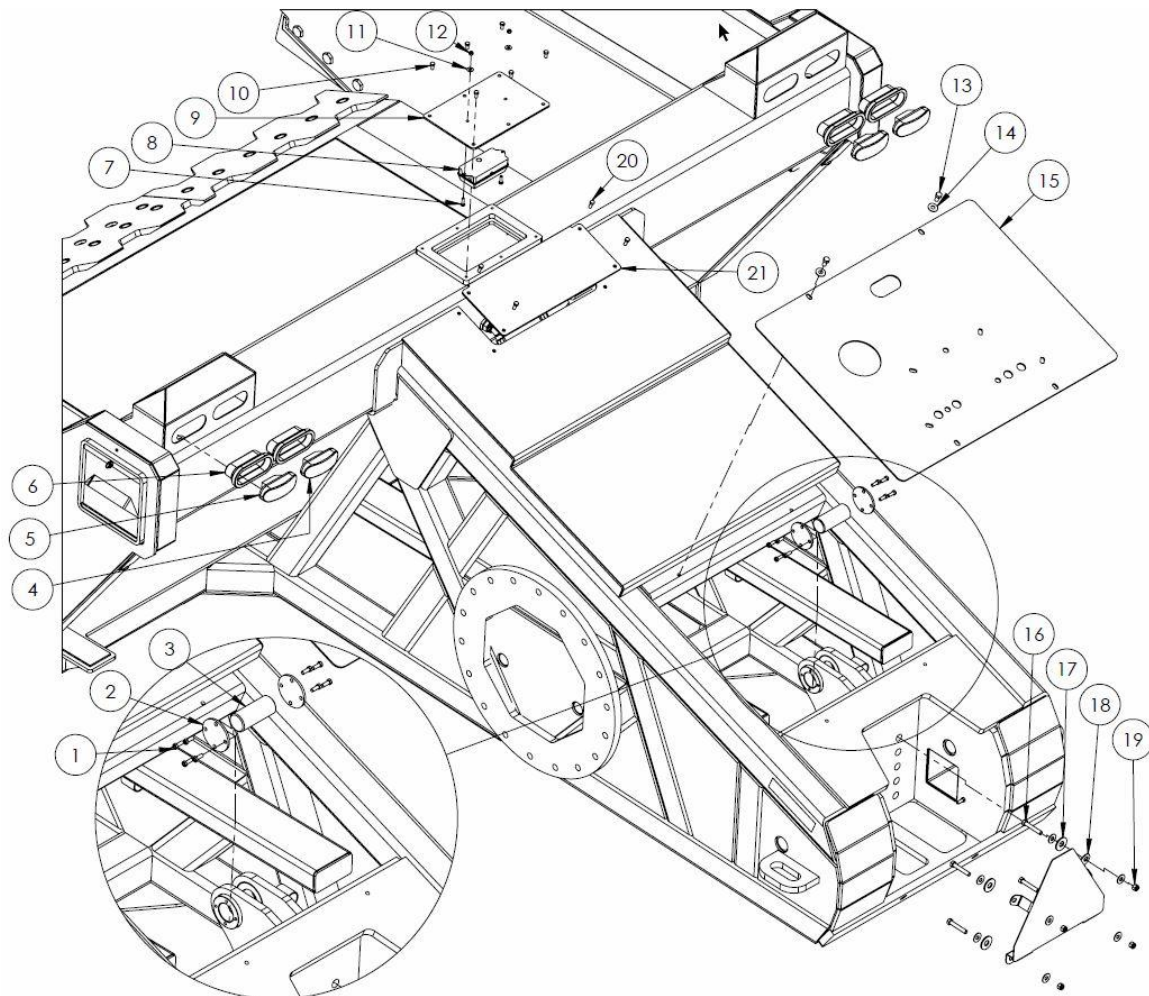

	Description	ID #	QTY		Description	ID #	QTY
1	Bolt, 3/8" x 1" NF Gr. 8 *	30888	8	12	Nylon Lock Nut, 5/16"	11815	2
2	Pin Cover G	30884	2	13	Bolt, 1/2" x 1"	10824	4
3	Pin E	28232	1	14	Flat Washer, 1/2"	11668	12
4	Red Oval LED Light	21721	2	15	Ejector Access Panel	31983	1
5	Amber Oval LED Light	21722	2	16	Bolt, 1/2" x 3"	10321	4
6	LED Light Grommet	21723	4	17	Flat Washer, 3/4"	13717	4
7	Bolt, 5/16" x 1"	20906	2	18	Bolt-On SMV Bracket	30772	1
8	Junction Box	13668	1	19	Nylon Lock Nut, 1/2"	10241	4
9	Rear Top Tube Cover	30787	1	20	Bolt, 3/8" x 1"	13806	4
10	Bolt, 3/8" x 3/4"	11816	6	21	Rear Square Tube Access Plate	31336	1
11	Flat Washer, 5/16"	12496	2				

See "Hydraulic Cylinders Assembly" for ejector cylinder installation

*Use High Strength Low Temperature Loctite on 3/8" x 1" NF Gr. 8

4.3.10 Wheel Assembly

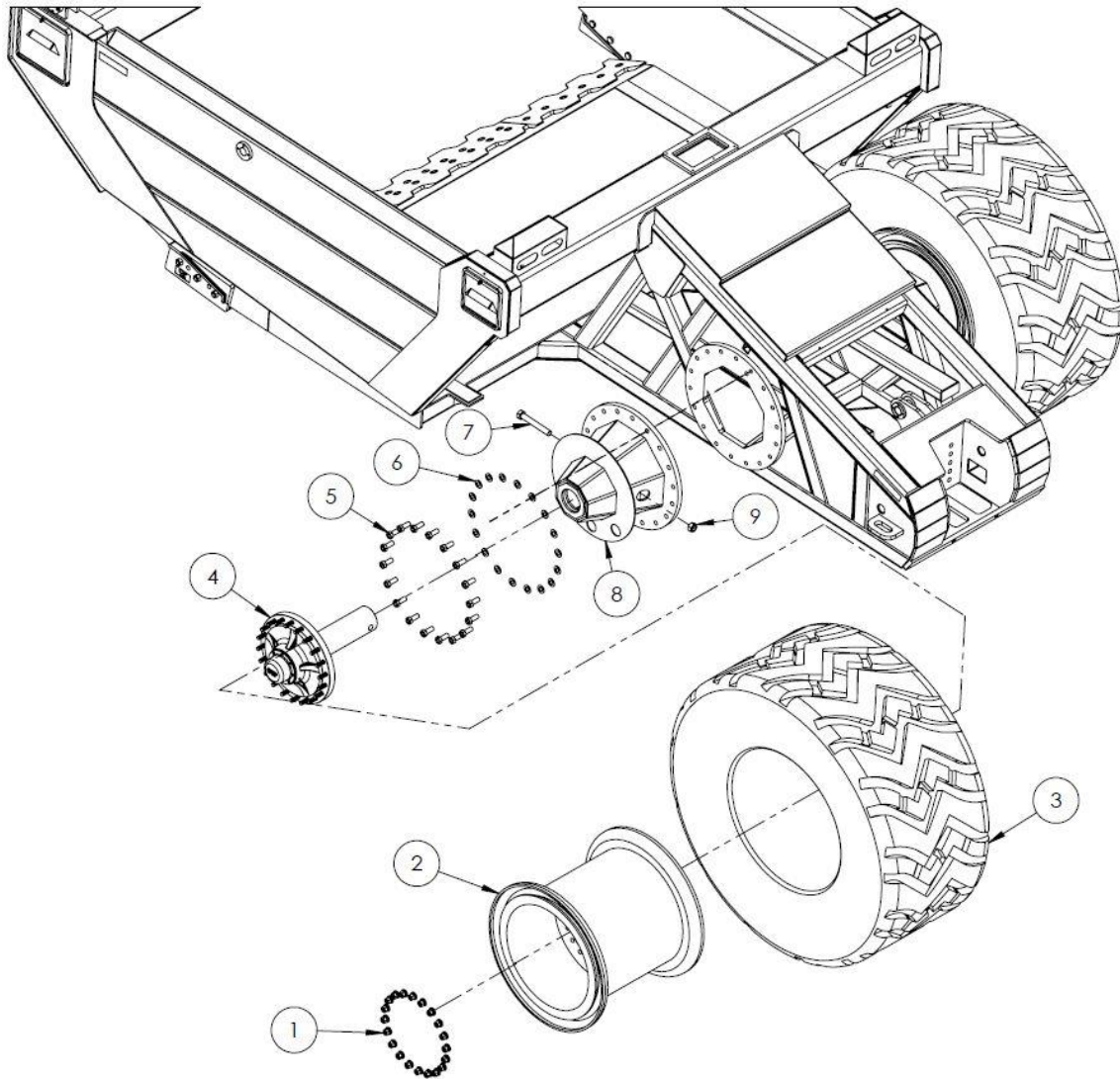

	Description	ID #	QTY		Description	ID #	QTY
1	Wheel Nuts **	31130	20	6	Flat Washer Hardened, 1"	31372	18
2	29" x 27" 5 Piece Rim	29010	2	7	Bolt, 1-1/4" x 9" NF Gr. 8	31112	2
3	875/65R29 Tire	#	2	8	Axle Cone	30789	2
4	Hub and Spindle	30478	2	9	Stover Lock Nut, 1-1/4" NF Gr. 8	31113	2
5	Bolt, 1" x 2-1/2" NF Gr. 8 *	30798	18				

** See 3.1 Wheels and Tires for wheel nuts torque

*Use High Strength Low Temperature Loctite on 1" x 2-1/2" NF Gr. 8 bolt

NOTE: See local tire dealership for replacement or tires

Quantities are per assembly as shown. Left side shown.

4.3.11 Hub and Spindle Assembly

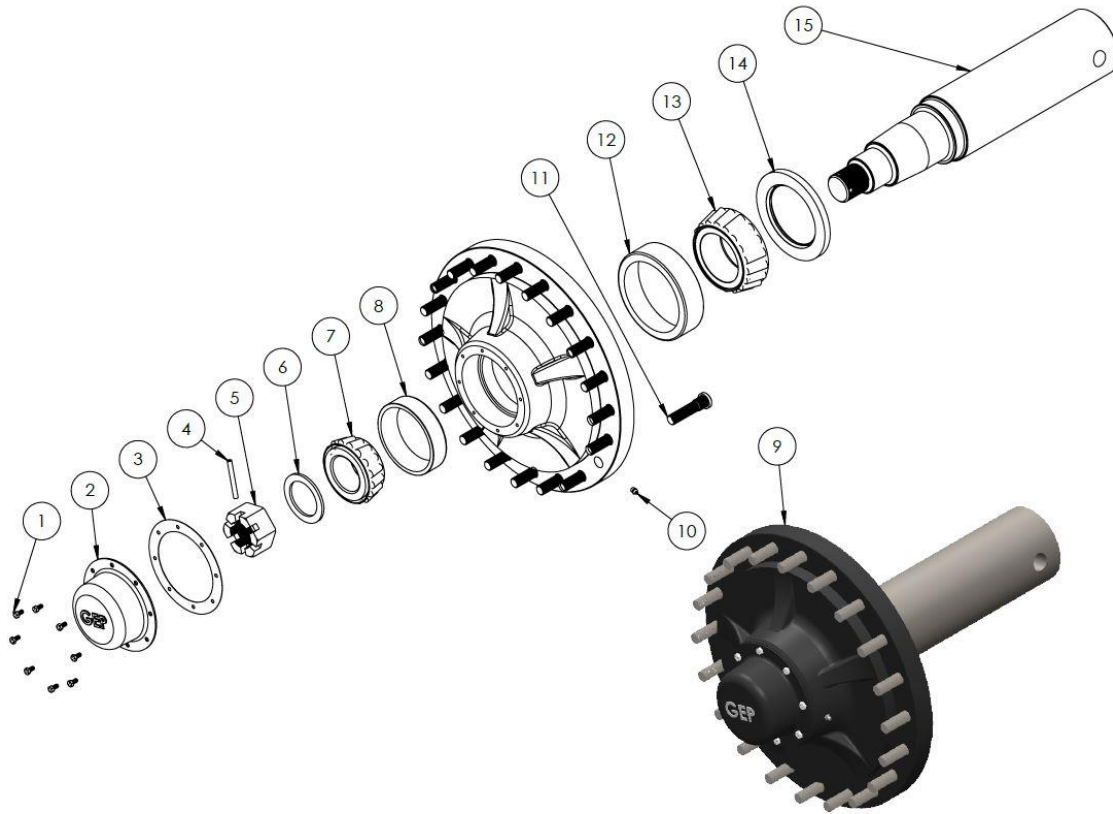

	Description	ID #	QTY		Description	ID #	QTY
1	Bolt, 5/16" x 5/8"	19530	8	9	Hub Assembly	30478	1
2	Dust Cap	31135	1	10	Grease Zerk, 1/8" NPT Straight	10270	1
3	Dust Cap Gasket	31136	1	11	Stud Bolt	31129	20
4	Roll Pin, 3/8" x 3-1/2"	TBA	1	12	Inner Cup	31131	1
5	Slotted Nut, 2-1/2	TBA	1	13	Inner Bearing	31133	1
6	Flat Washer, 2-5/8" ID x 4-1/2" OD	TBA	1	14	Inner Seal	31137	1
7	Outer Bearing	31134	1	15	Spindle	31138	1
8	Outer Cup	31132	1				

**Quantities are per assembly as shown.
TBA: To Be Announced**

4.4 Ejector Assembly

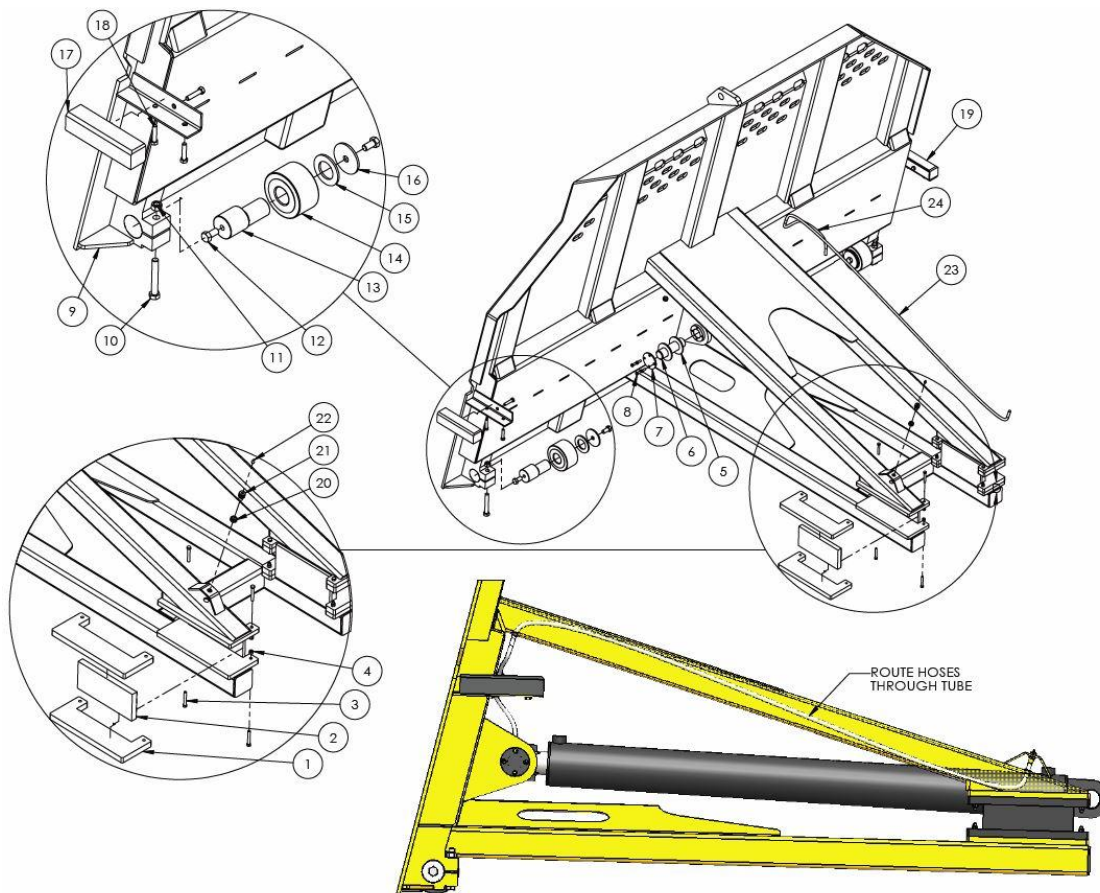

	Description	ID #	QTY		Description	ID #	QTY
1	Ejector Abrasion Plate C	30627	4	13	Roller Shaft	28959	2
2	Ejector Abrasion Plate B	28265	2	14	Cam Bearing	28955	2
3	Bolt, 3/8" x 2-1/2"	26307	8	15	Roller Spacer	31128	2
4	Nylon Lock Nut, 3/8"	10806	8	16	Roller Washer	29048	2
5	Plastic Bushing A	28221	2	17	Left Hand Ejector Abrasion Bar	28263	1
6	Pin G	28273	1	18	Bolt, 1/2" x 2-1/4"	11820	6
7	Pin Cover F	30882	2	19	Right Hand Ejector Abrasion Bar	28262	1
8	Bolt, 3/8" x 1" NF Gr. 8 *	30888	8	20	Rubber Grommet	31656	2
9	20-yard Ejector	30604	1	21	Bulkhead fitting	16830	1
10	Bolt, 3/4" x 5"	17826	2	22	Grease fitting, 1/8" NPT Straight	10270	1
11	Hex Nut, 3/4"	10283	2	23	Grease hose, 98" OAL	31947	1
12	Bolt, 3/4" x 1-1/2"	13794	4	24	Zip tie	12041	1

See "Hydraulic Cylinders Assembly" for ejector cylinder installation
 *Use High Strength Low Temperature Loctite on 3/8" x 1" NF Gr. 8

4.5 Apron Assembly (S/N PD1268 & Down)

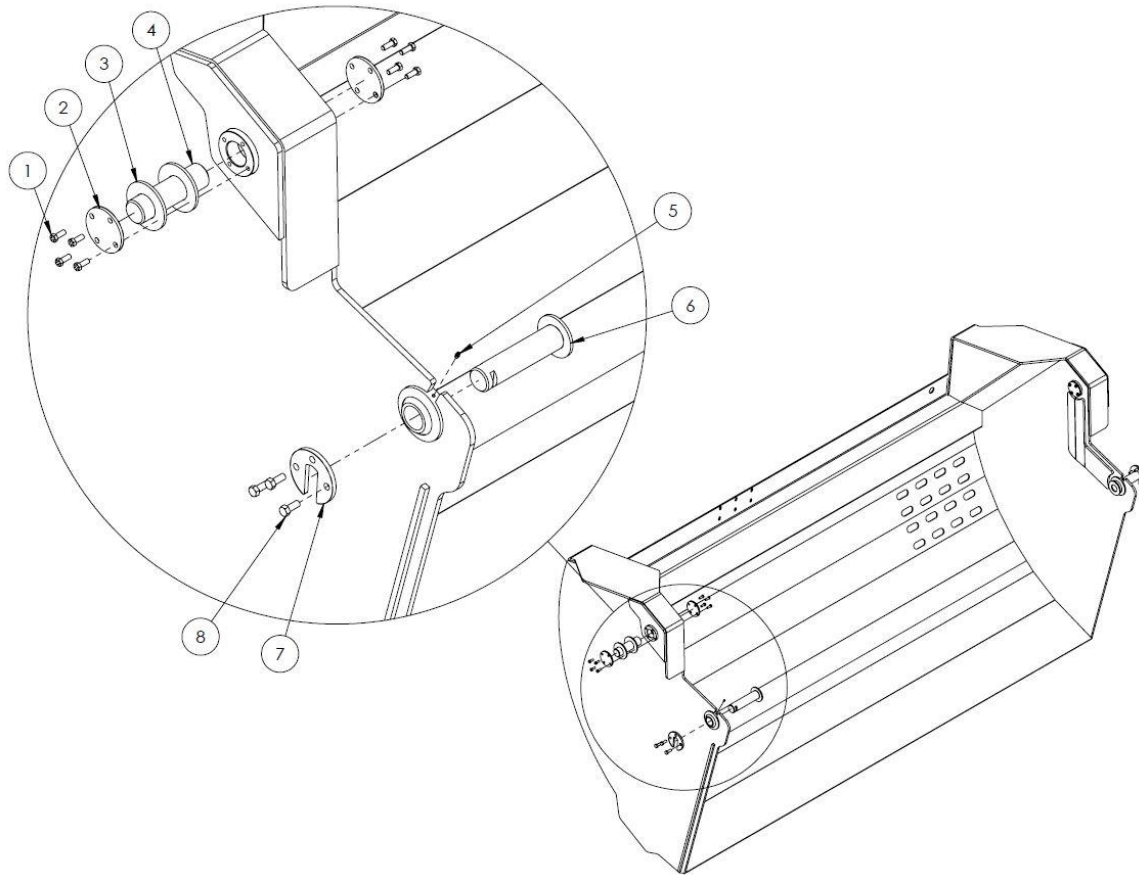

	Description	ID #	QTY		Description	ID #	QTY
1	Bolt, 3/8" x 1" NF Gr. 8 *	30888	16	5	Grease Zerk, 1/4"-28	16364	2
2	Pin Cover F	30882	4	6	Apron Pin	28364	2
3	Plastic Bushing A	28221	4	7	Apron Pin Cover	28296	2
4	Pin G	28273	2	8	Bolt, 1/2" x 1-1/4"	10240	6

See "Hydraulic Cylinders Assembly" for apron cylinder installation
 *Use High Strength Low Temperature Loctite on 3/8" x 1" NF Gr. 8

4.6 Apron Assembly (S/N PD1269 & Up)

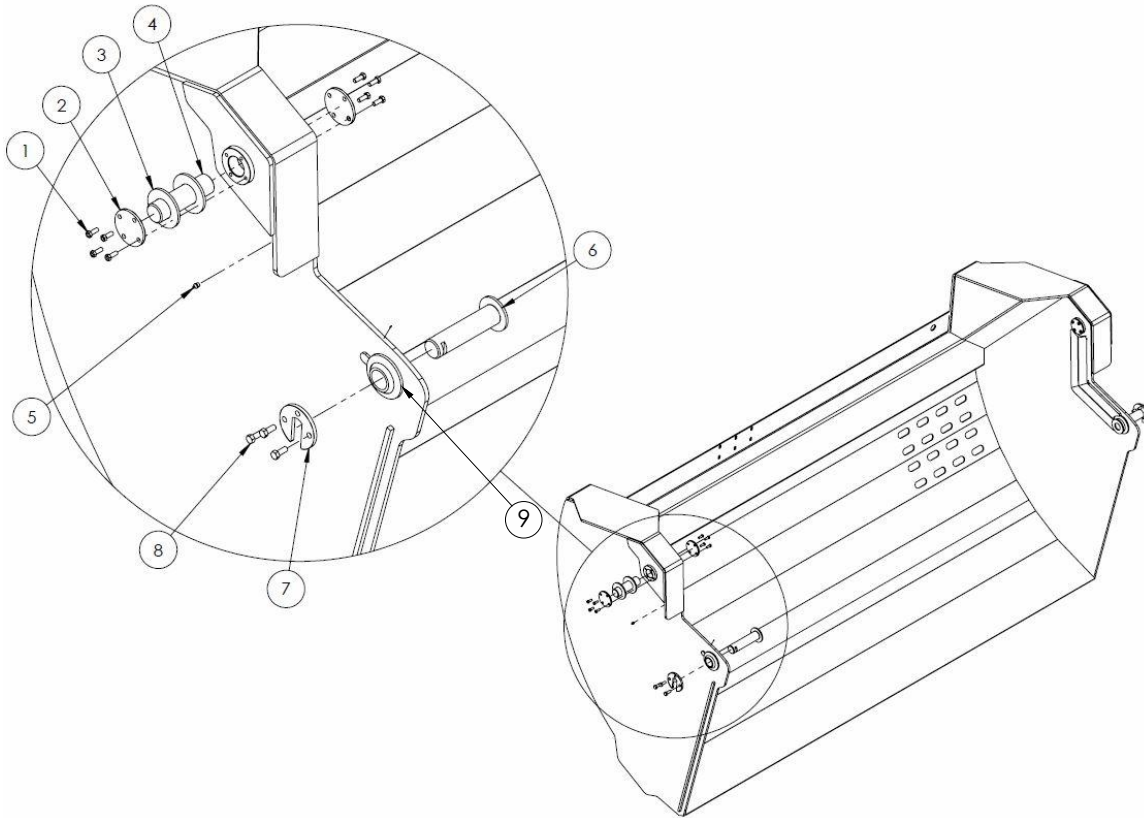

	Description	ID #	QTY		Description	ID #	QTY
1	Bolt, 3/8" x 1" NF Gr. 8 *	30888	16	6	Apron Pin	28364	2
2	Pin Cover F	30882	4	7	Apron Pin Cover	28296	2
3	Plastic Bushing A	28221	4	8	Bolt, 1/2" x 1-1/4" NF Gr. 8 *	31945	6
4	Pin G	28273	2	9	Apron Eyeball	29361	2
5	Grease zerker, 1/8" NPT Straight	10270	2				

See "Hydraulic Cylinders Assembly" for apron cylinder installation

*Use High Strength Low Temperature Loctite on 3/8" x 1" NF Gr. 8 & 1/2" x 1-1/4" NF Gr. 8

4.7 Hydraulic Cylinders Assembly

Add one ¼”90° Grease Zerk (15871) onto ram ends of lift cylinders for easier greasing.

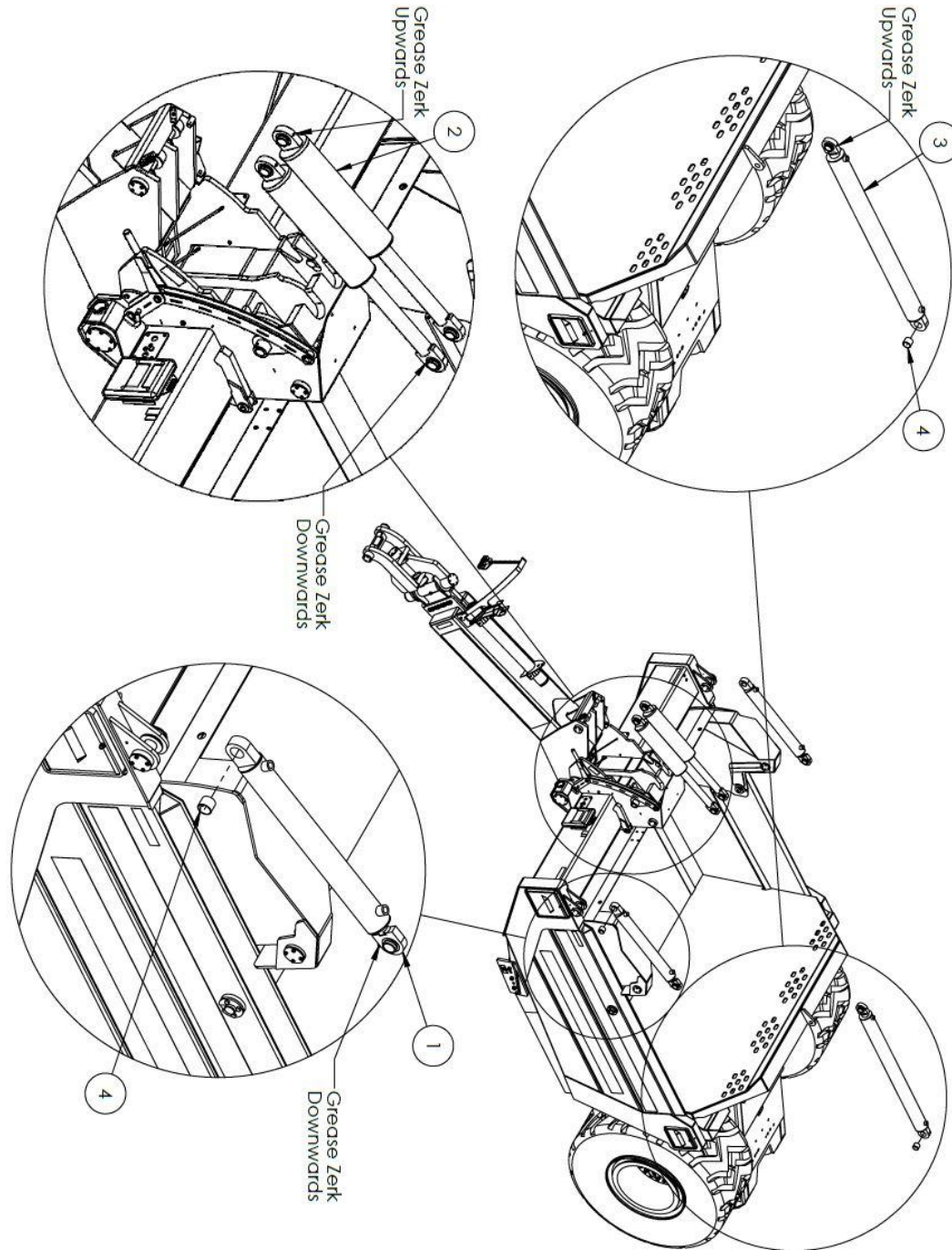

	Description	ID #	QTY		Description	ID #	QTY
1	Apron Cylinder	28401	2	3	Ejector Cylinder	28402	1
2	Lift Cylinder	29028	2	4	Spring Bushing	28532	3

(a) 4.7.1 Alignment Collars

There is potential for the lift cylinder eyeball tab to be forced off the eyeball bearing. This will cause damage to the lift cylinder. If the cylinder is not centered within the bearing you must push the cylinder tab back to the center of the bearing.

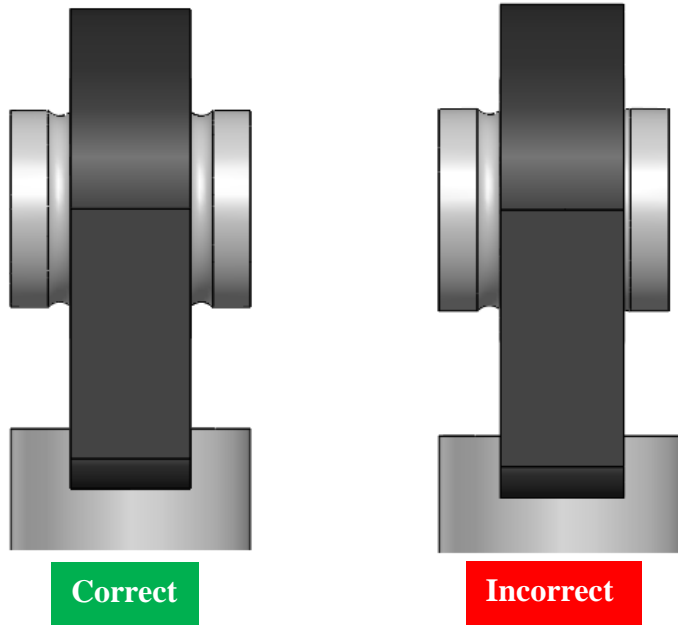

Install the two-piece collars (x8) (32028) onto the cylinders at both ends, barrel and shaft end, along with both sides of the tab as shown below.

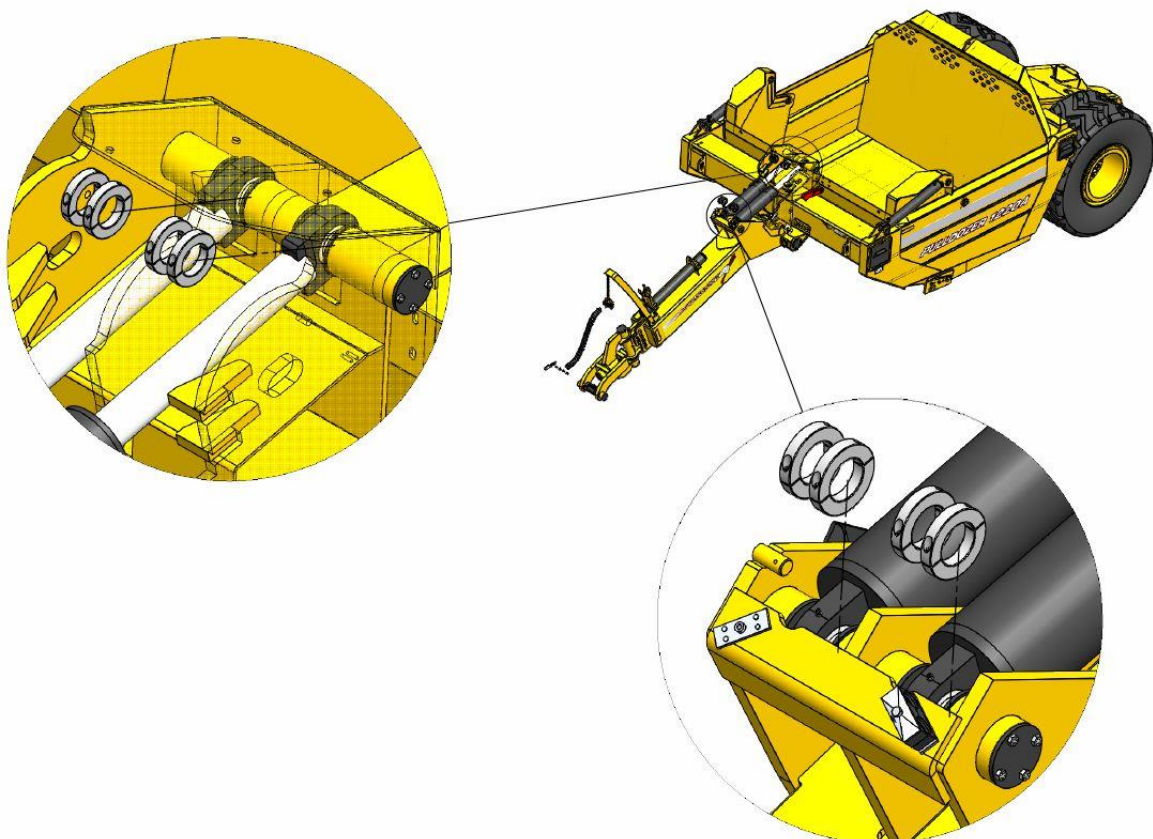

4.8 Decals

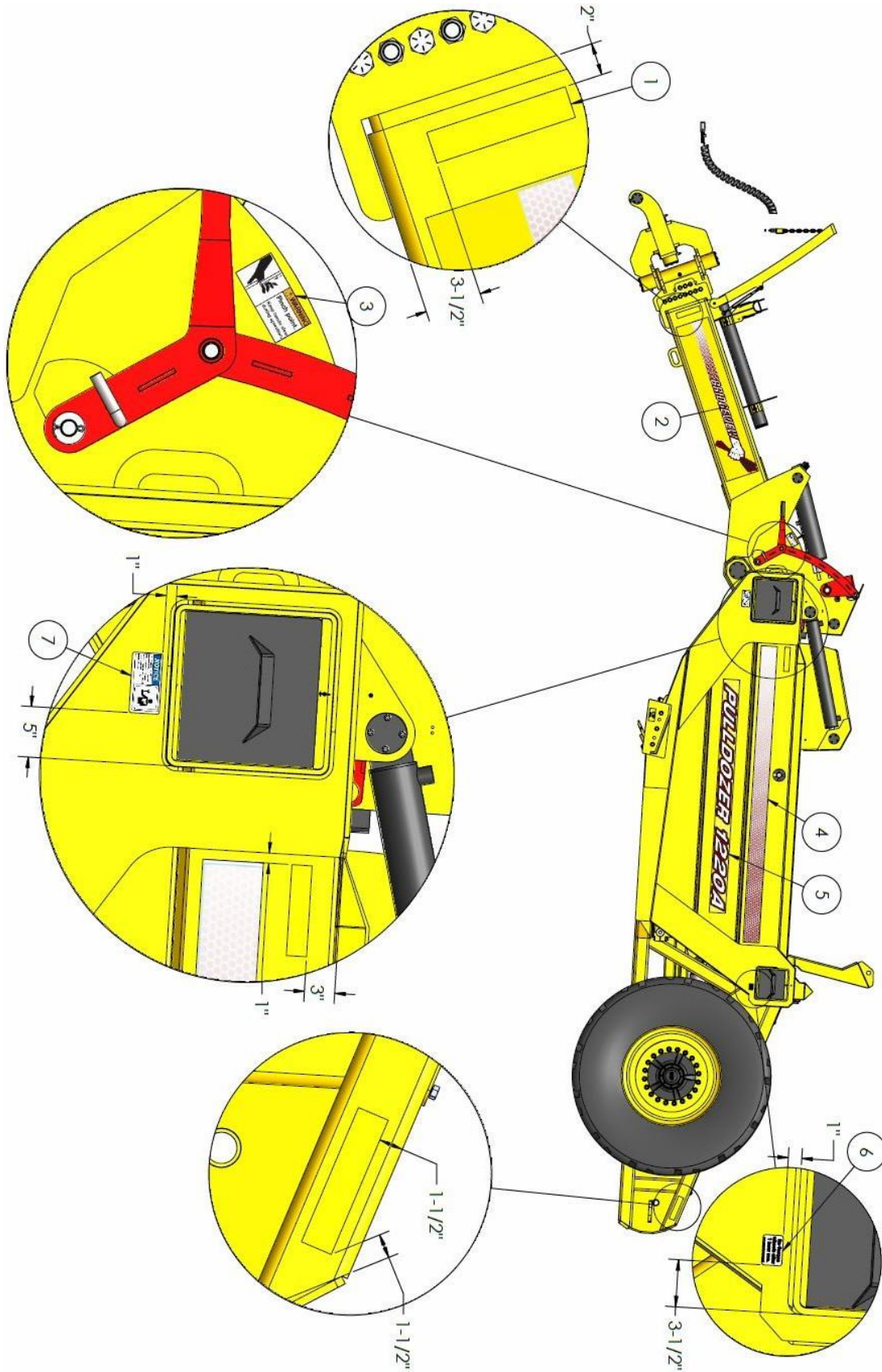

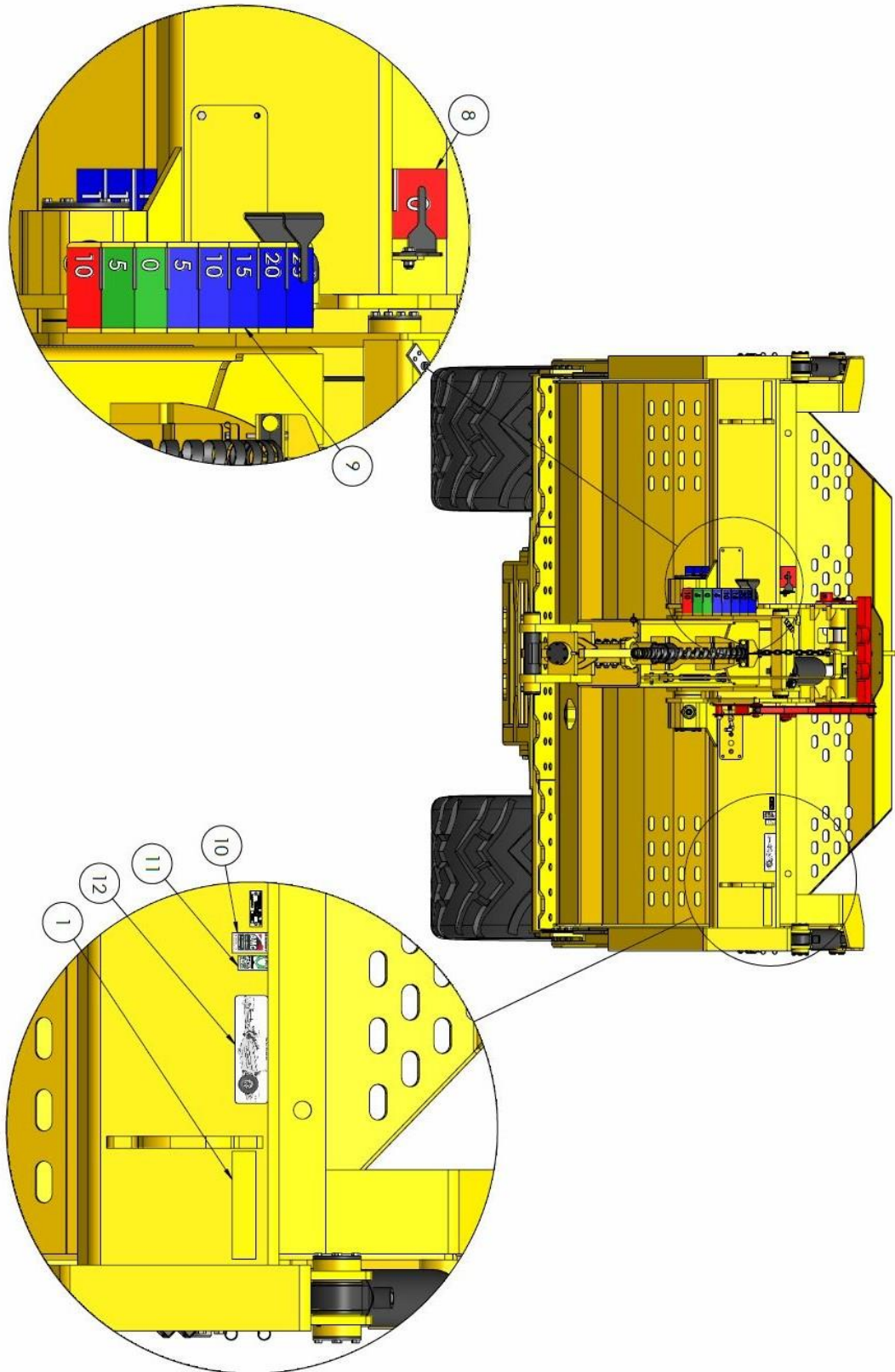

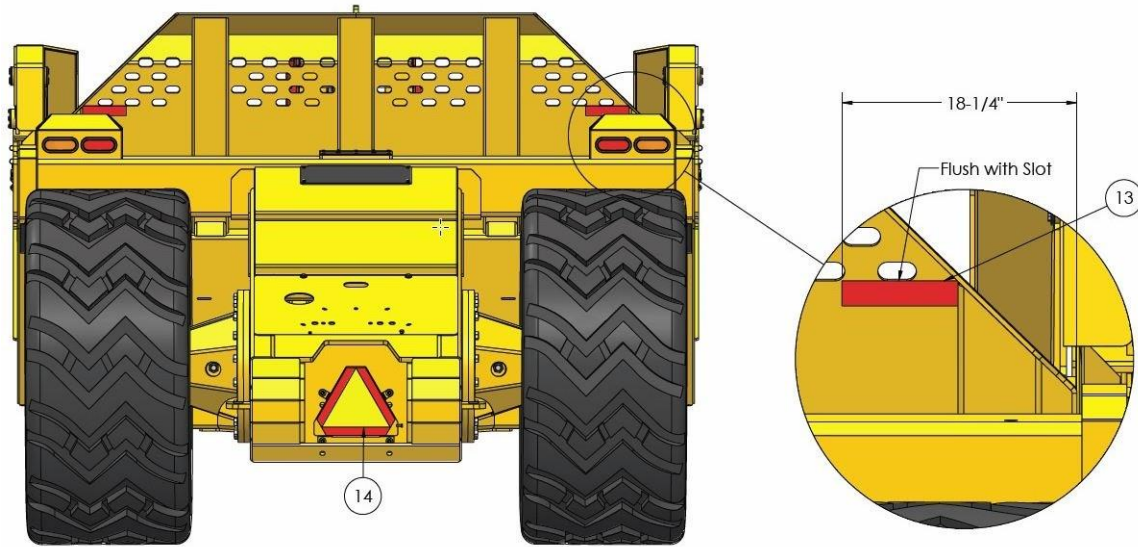

	Description	ID #	QTY		Description	ID #	QTY
1	Yellow Reflector	28384	8	8	Apron Height Indicator Decal	30602	1
2	LH Hitch Decal	28430	1	9	Blade Height Indicator Decal	30941	1
2	RH Hitch Decal	28431	1	10	AMC Decal	12239	1
3	Pinch Point Decal	28433	2	11	FEMA Decal	25347	1
4	Bowl Gradient Decal	28429	2	12	Scraper Grease Locations	31948	1
5	1220A Bowl Decal	30920	2	13	Red Reflector	28383	2
6	Wheel Torque Reminder Decal	28385	2	14	SMV Decal	12228	1
7	Operators Manual Notice Decal	31950	1				

4.9 Hydraulic Components

4.9.1 Hydraulic Schematic

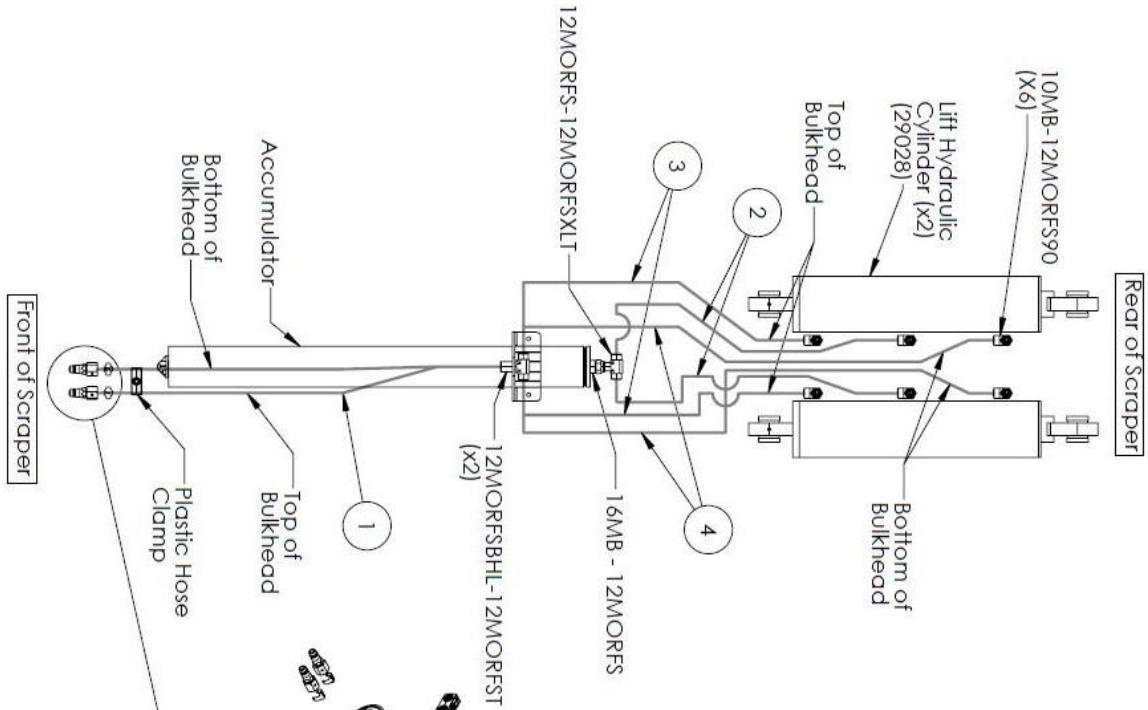

Hose #	Length (inches)	Ends	Qty
1	134	12MB-12FORFSX45	2
2	38	12FORFSX-12FORFSX90	2
3	36	12FORFSX-12FORFSX90	2
4	61	12FORFSX-12FORFSX90	2

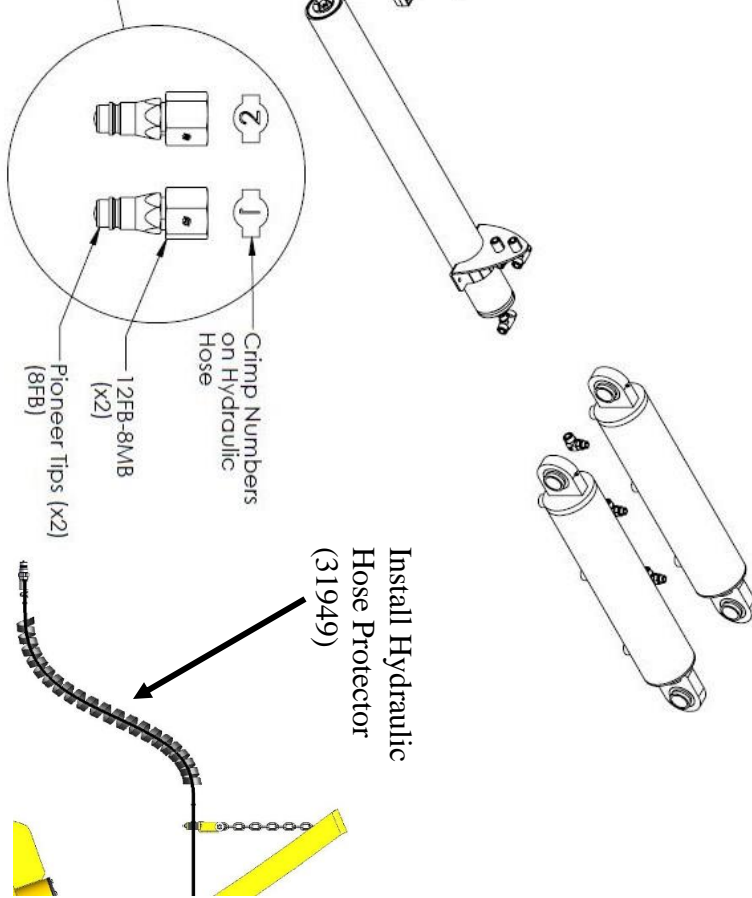

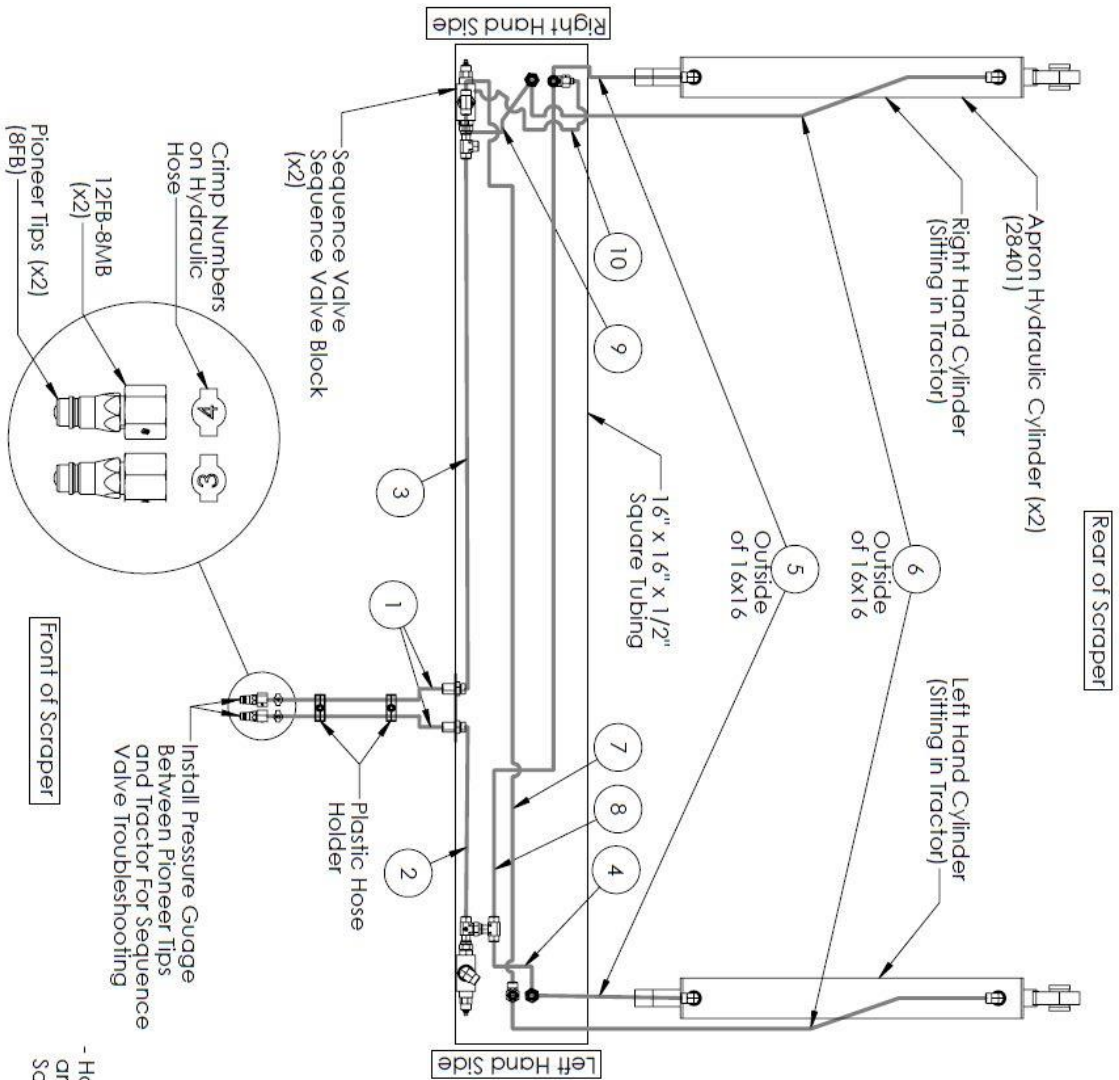

Hose #	Length (inches)	Ends	Qty
1	213	12MB-12FORFSX90	2
2	34	12MB-12FORFSX90	1
3	67	12MB-12FORFSX90	1
4	17.75	12MB-12FORFSX	1
5	19.5	12MB-12FORFSX	2
6	57	12MB-12FORFSX	2
7	138	12MB-12FORFSX90	1
8	125	12MB-12FORFSX45	1
9	52	12MB-12FORFSX90	1
10	23.25	6MB-6FORFSX45	1

- Hose Numbers 2, 3, 4, 7, 8, 9 and 10 are all within the 16" x 16" x 1/2" Square Tubing

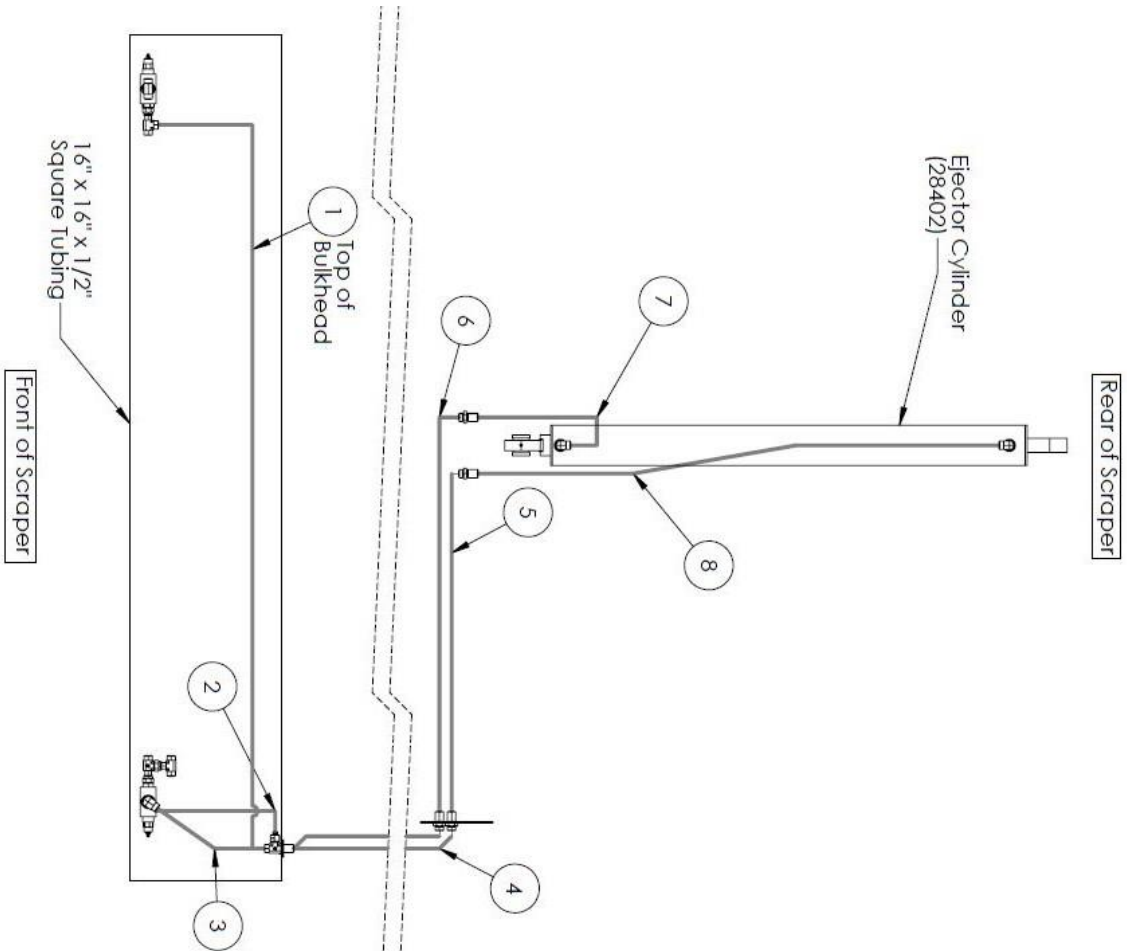

Hose #	Length (inches)	Ends	Qty
1	132	12MB-12FORFSX90	1
2	15.75	6MB-6FORFSX45	1
3	15.5	12MB-12FORFSX45	1
4	143	12MB-12FORFSX90	2
5	67	12MB-12FORFSX45	1
6	70	12MB-12FORFSX45	1
7	38	12MB-12FORFSX45	1
8	64	12MB-12FORFSX45	1

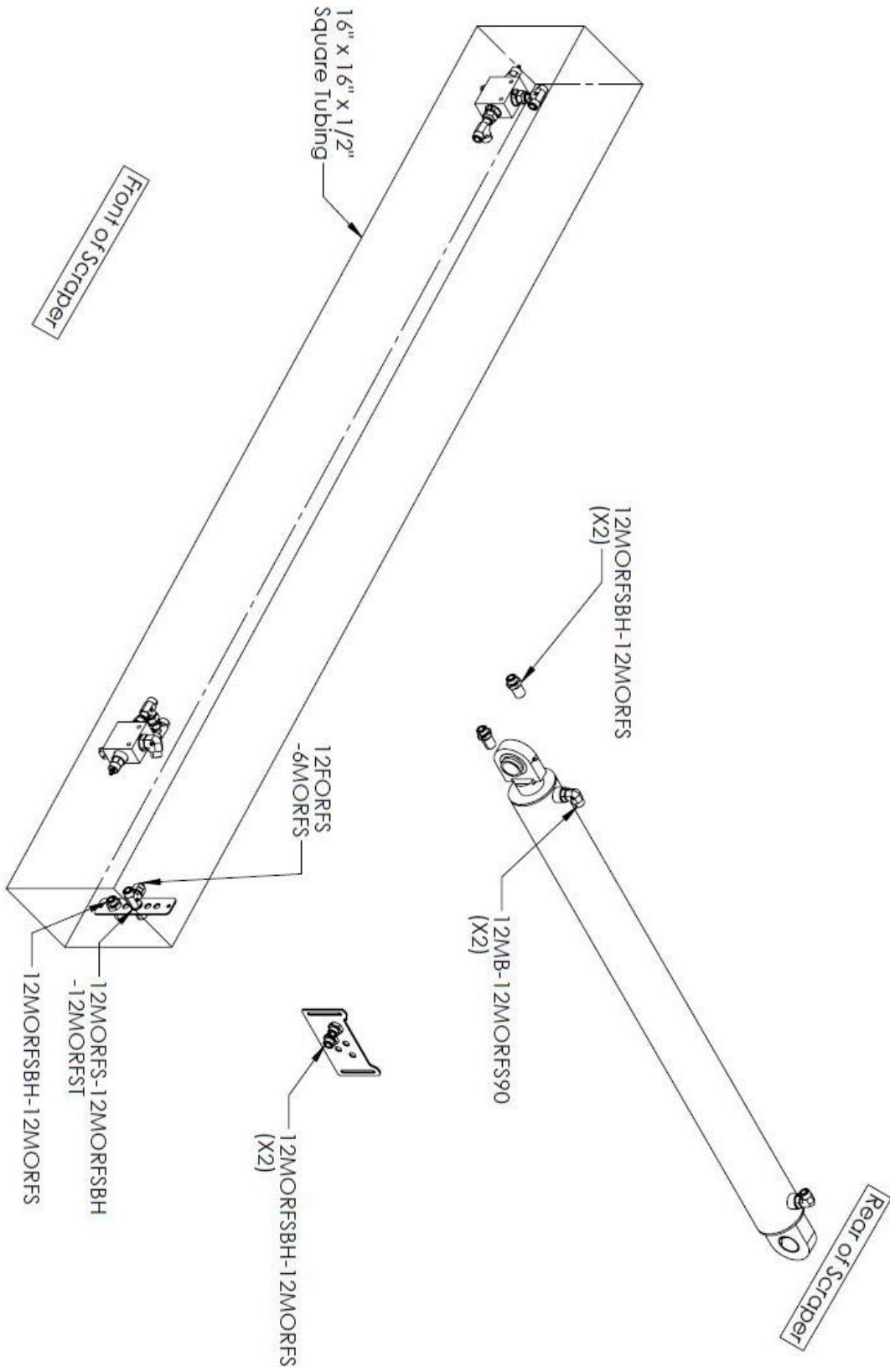

4.10 Electrical Components

4.10.1 Light Wiring Schematic

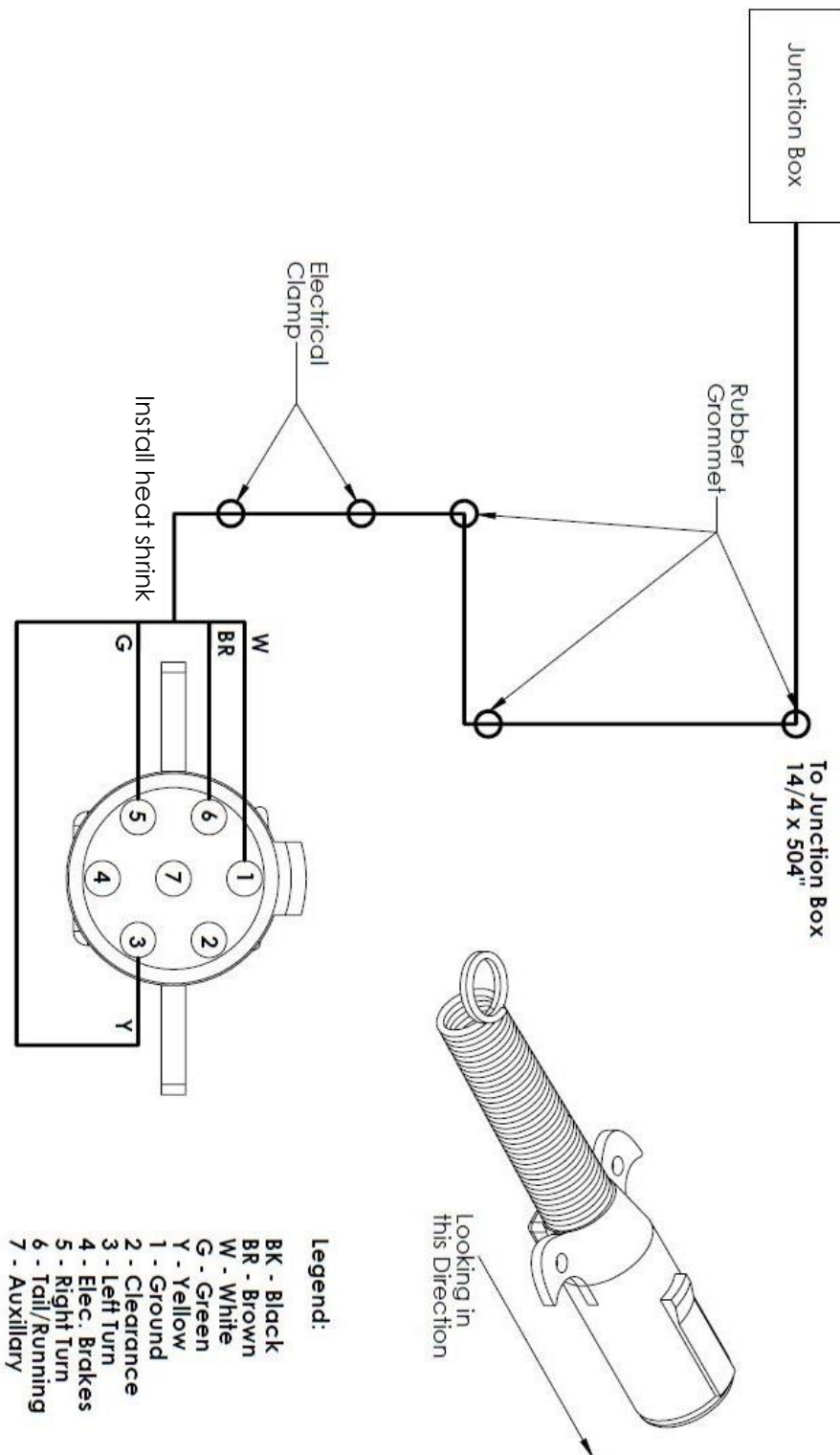

Tighten all nuts
Install junction box lid
after assembly

Yellow Ring Connector (x2)
ID# 14406
Connect both black wires
Connect both white wires

Blue Ring Connector
ID# (x6) 21455

Route the pigtail from the red grommet into the amber grommet
Bring the 14/3 wire into the bottom of the amber grommet
Solder the pigtail connections together to the 14/3 wire
Cover the connections with heat shrink

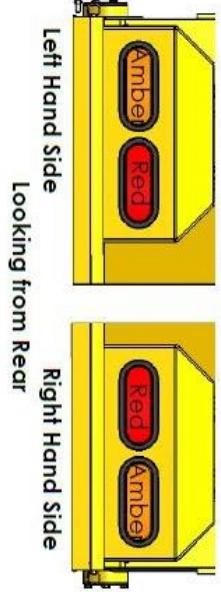
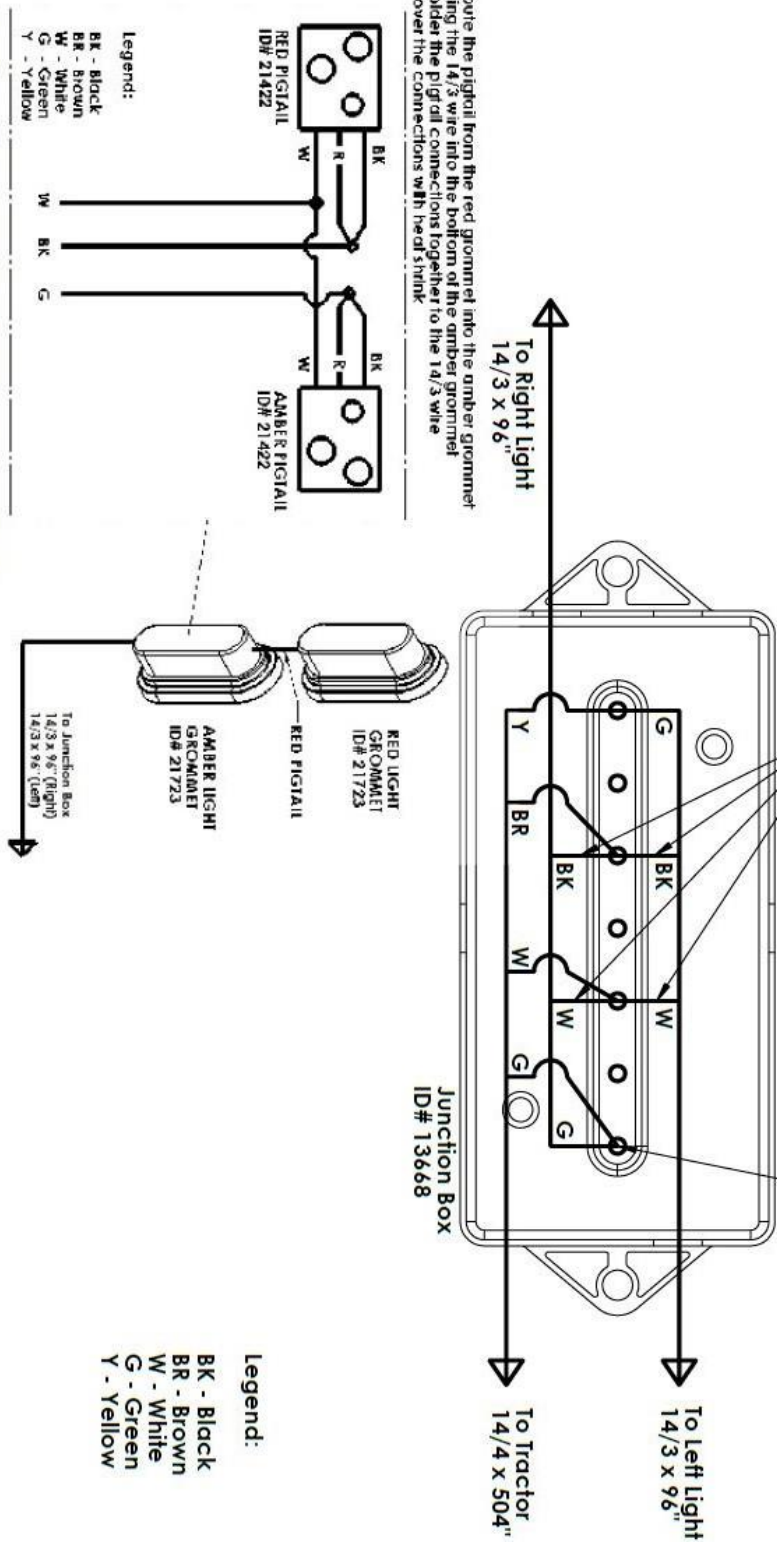

- ASSEMBLY IS NOW COMPLETE -

5. Bolt Torque Values

FASTENER TORQUE CHARTS

		BOLT CLAMP LOADS								
		USS/SAE GRADE 5					USS/SAE GRADE 8			
DIAMETER & THREADS PER INCH	TENSILE STRENGTH MIN. PSI	PROOF LOAD LB	CLAMP LOAD LB	TORQUE DRY FT LB	LUBRICATED FT LB	TENSILE STRENGTH MIN. PSI	PROOF LOAD LB	CLAMP LOAD LB	TORQUE DRY FT LB	LUBRICATED FT LB
	1/4-20 28	120,000	2,700	2,020	8	6.3	150,000	3,800	2,850	12
120,000		3,100	2,320	10	7.2	150,000	4,350	3,250	14	10
5/16-18 24	120,000	4,450	3,340	17	13	150,000	6,300	4,700	24	18
	120,000	4,900	3,700	19	14	150,000	6,950	5,200	27	20
3/8-16 24	120,000	6,600	4,950	30	23	150,000	9,300	6,980	45	35
	120,000	7,450	5,600	35	25	150,000	10,500	7,900	50	35
7/16-14 20	120,000	9,050	6,780	50	35	150,000	12,800	9,550	70	50
	120,000	10,100	7,570	55	40	150,000	14,200	10,650	80	60
1/2-13 20	120,000	12,100	9,050	75	55	150,000	17,000	12,750	110	80
	120,000	13,600	10,200	85	65	150,000	19,200	14,400	120	90
9/16-12 18	120,000	15,500	11,600	110	80	150,000	21,800	16,350	150	110
	120,000	17,300	12,950	120	90	150,000	24,400	18,250	170	130
5/8-11 18	120,000	19,200	14,400	150	110	150,000	27,100	20,350	210	160
	120,000	21,800	16,350	170	130	150,000	30,700	23,000	240	180
3/4-10 16	120,000	28,400	21,300	260	200	150,000	40,100	30,100	380	280
	120,000	31,700	23,780	300	220	150,000	44,800	33,500	420	310
7/8-9 14	120,000	39,300	29,450	430	320	150,000	55,400	41,600	600	450
	120,000	43,300	32,450	470	350	150,000	61,100	45,800	670	500
1-8 14	120,000	51,500	38,600	640	480	150,000	72,700	54,500	910	680
	120,000	57,700	43,300	720	540	150,000	81,500	61,100	1,020	760

When using anti-seize, reduce the lubed chart reading by 20% to properly torque. Always lubricate and use lubed torque values.

Torques for Grades 5 and 8 were calculated based on the following relationship:

$$T = R D P$$

Where: T = Torque (ft lb)

D = Nominal Diameter (in)

P = Clamp Load (lb)

R = Tightening Coefficient

The value of R is assumed to be equal to .20 for dry, unplated conditions and equal to .15 for lubricated, including plated, conditions. Actual values of R can vary between .05 and .35 for commonly encountered conditions.

NOTES:

The above recommended assembly torques are offered as a guide only. Torque specifications, especially for critical joints, should be determined under actual assembly conditions due to the many variables involved which are difficult to predict and do affect the torque-tension relationship.

The above recommended clamp loads are based on 75% of the minimum specified proof loads for each grade and size.

STRENGTH GRADE	APPLICABLE SIZES	PROOF LOAD STRESS (PSI)	YIELD STRENGTH MIN. STRESS (PSI)	TENSILE STRESS MIN. (PSI)
SAE Gr. 5	1/4 to 1" diameter over 1" diameter to 1-1/2 diameter	85,000	92,000	120,000
		74,000	81,000	105,000
SAE Gr. 8	1/4 to 1" diameter	120,000	130,000	150,000

Pounds to Inch Pound Conversion

lb x 12 = inch lb

Example: 9 lb x 12 = 108 inch lb

FRACTIONAL MEASUREMENT		
BOLT DIAMETER	CAP SCREW WRENCH SIZE	NUT WRENCH SIZE
1/4	7/16	7/16
5/16	1/2	1/2
3/8	9/16	9/16
7/16	5/8	11/16
1/2	3/4	3/4
9/16	13/16	7/8
5/8	15/16	15/16
3/4	1-1/8	1-1/8
7/8	1-5/16	1-5/16
1"	1-1/2	1-1/2
1-1/8	1-11/16	1-11/16
1-1/4	1-7/8	1-7/8
1-3/8	2-1/16	2-1/16
1-1/2	2-1/4	2-1/4
1-3/4	2-5/8	2-5/8
2"	3"	3"
2-1/4	3-3/8	3-3/8
2-1/2	3-3/4	3-3/4
2-3/4	4-1/8	4-1/8
3"	4-1/2	4-1/2

Imperial has made a concerted effort to provide accurate information in its catalog and on its website, however Imperial assumes no responsibility for the accuracy of the information. All information published by Imperial in its catalogs, marketing literature, and on its website is provided "as is" without warranty, expressed or implied. Imperial and its vendors disclaim all warranties, expressed or implied including, without limitation, warranties of merchantability and fitness for a particular purpose.



FASTENER TORQUE CHARTS

GUIDE FOR PREVAILING-TORQUE LOCK NUT ASSEMBLY TORQUES (CAD AND WAX, GRADE B, C, AND GRADE G FLANGE NUTS) LOCK NUT STANDARDS FROM IFI-100 REQUIREMENTS



Torque-Tension Requirements

Size Threads Per Inch	GRADE B			GRADE C			GRADE G		
	CLAMP LOAD (Lb)	ASSEMBLY TORQUE		CLAMP LOAD (Lb)	ASSEMBLY TORQUE		CLAMP LOAD (Lb)	ASSEMBLY TORQUE	
		MAX.	MIN.		MAX.	MIN.		MAX.	MIN.
1/4-20	2,000	85**	60**	2,850	125**	85**	2,850	150**	100**
1/4-28	2,300	90**	65**	3,250	125**	85**	3,250	160**	105**
5/16-18	3,350	150**	110**	4,700	190**	130**	4,700	240**	155**
5/16-24	3,700	160**	120**	5,200	200**	140**	5,200	230**	155**
3/8-16	4,950	20	14.5	6,950	28	20	6,950	32	21
3/8-24	5,600	22	16	7,900	29	21	7,900	33	22
7/16-14	6,800	32	23	9,600	43	31	9,600	51	34
7/16-20	7,550	34	24	10,700	43	31	10,700	60	40
1/2-13	9,050	50	37	12,800	62.5	45	12,800	85	55
1/2-20	10,200	52.5	37.5	14,440	70	50	14,440	89	59
9/16-12	11,600	70	50	16,400	95	70	16,400	120	80
9/16-18	13,000	77.5	57.5	18,300	95	70	18,300	132	88
5/8-11	14,500	95	70	20,300	122.5	90	20,300	143	95
5/8-18	16,300	97.5	72.5	23,000	125	90	23,000	175	115
3/4-10	21,300	165	125	30,100	210	155	30,100	240	160
3/4-16	23,800	165	120	33,600	210	155	33,600	270	170
7/8-9	29,500	250	185	41,600	312.5	225	41,600	360	260
7/8-14	32,400	270	200	45,800	312.5	225	45,800	402	247
1-8	38,700	375	275	54,600	462.5	360	54,600	530	410
1-12	42,300	395	290	59,750	490	360	59,750	—	—
1-14	43,000	400	300	61,100	500	362.5	61,100	645	398
1-1/8-7	42,100	404	294	69,000	585	454	69,000	—	—
1-1/8-12	47,500	437	327	76,800	622	453	76,800	—	—
1-1/4-7	53,500	513	375	87,000	736	573	87,000	—	—
1-1/4-12	59,700	549	412	96,600	782	570	96,600	—	—
1-3/8-6	63,800	612	445	104,000	880	685	104,000	—	—
1-3/8-12	72,900	670	503	118,000	955	696	118,000	—	—
1-1/2-6	77,600	745	545	127,000	1,075	837	127,000	—	—
1-1/2-12	87,700	807	605	142,000	1,150	837	142,000	—	—

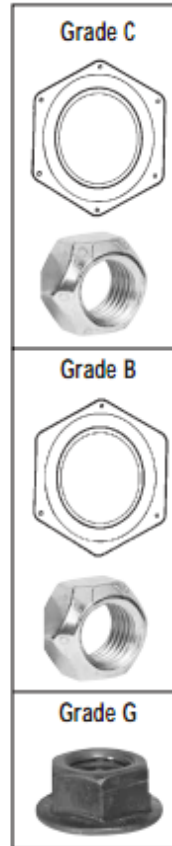
- Clamp loads for the Grade B lock nuts equal 75% of the bolt proof loads specified for SAE J-429 Grade 5, and ASTM A-449 bolts.
- Clamp loads for Grade C lock nuts equal 75% of the bolt proof loads specified for SAE J-429 Grade 8, and ASTM A-354 Grade BD bolts.
- IFI-100 does not govern lock nuts above 1". The values shown in the chart are to be used as a mid-range guideline.
- ** Torque values for 1/4" and 5/16" sizes are in Inch lb. All other torque values are in foot lb.



METRIC TORQUE CHART FOR HEX HEAD CAP SCREWS

Size	CLASS	NEWTON METERS		FOOT POUNDS (APPROX.)		CLASS
		ZINC PLATED	UNPLATED	ZINC PLATED	UNPLATED	
M4 x .70 Pitch	8.8	3.1	2.2	2.30	1.65	
M5 x .80 Pitch	8.8	6.1	5.5	4.58	4.13	
M6 x 1.00 Pitch	8.8	10.4	9.5	7.80	7.13	
M7 x 1.00 Pitch	8.8	17.0	15.5	12.75	11.63	
M8 x 1.25 Pitch	8.8	25.0	23.0	18.75	17.25	
M8 x 1.00 Pitch	8.8	27.0	24.5	20.25	18.38	
M10 x 1.50 Pitch	8.8	51.0	46.0	38.25	34.50	
M10 x 1.00 Pitch	8.8	57.0	52.0	42.75	39.00	
M10 x 1.25 Pitch	8.8	54.0	49.0	40.50	36.75	
M12 x 1.75 Pitch	8.8	87.0	79.0	65.25	59.25	
M12 x 1.25 Pitch	8.8	96.0	87.0	72.00	65.25	
M12 x 1.50 Pitch	8.8	92.0	83.0	69.00	62.25	
M14 x 2.00 Pitch	8.8	140.0	125.0	105.00	93.75	
M14 x 1.50 Pitch	8.8	150.0	135.0	112.50	101.25	
M16 x 2.00 Pitch	8.8	215.0	195.0	161.25	146.25	
M18 x 2.50 Pitch	8.8	300.0	280.0	225.00	210.00	
M20 x 2.50 Pitch	8.8	430.0	390.0	322.50	292.50	
M22 x 2.50 Pitch	8.8	580.0	530.0	435.00	397.50	
M24 x 3.00 Pitch	8.8	740.0	670.0	555.00	502.50	
M6 x 1.00 Pitch	10.9	15.5	14.0	11.63	10.50	
M8 x 1.25 Pitch	10.9	37.0	34.0	27.75	25.50	
M10 x 1.50 Pitch	10.9	75.0	68.0	56.25	51.00	
M12 x 1.75 Pitch	10.9	160.0	117.0	97.50	87.75	
M14 x 2.00 Pitch	10.9	205.0	185.0	153.75	138.75	
M16 x 2.00 Pitch	10.9	310.0	280.0	232.50	210.00	

TORQUE CHART FOR STAINLESS STEEL CAP SCREWS

SIZE	316 INCH-LB	18/8 INCH-LB
6-32	10.1	9.6
6-40	12.7	12.1
8-32	20.7	19.8
8-36	23.0	22.0
10-24	23.8	22.8
10-32	33.1	31.7
1/4-20	78.8	75.2
1/4-28	99.0	94.0
5/16-18	138.0	132.0
5/16-24	147.0	142.0
3/8-16	247.0	236.0
3/8-24	271.0	259.0
7/16-14	393.0	376.0
7/16-20	418.0	400.0
1/2-13	542.0	517.0
1/2-20	565.0	541.0
9/16-12	713.0	682.0
9/16-18	787.0	752.0
5/8-11	1,160.0	1,110.0
5/8-18	1,301.0	1,244.0
3/4-10	1,582.0	1,530.0
3/4-16	1,558.0	1,490.0
7/8-9	2,430.0	2,328.0
7/8-14	2,420.0	2,318.0
1"-8	3,595.0	3,440.0
1"-14	3,250.0	3,110.0

PHONE: 1-800-558-2808

FAX: 1-800-553-8769

WEB: www.imperialsupplies.com



6. Troubleshooting

The following is a list of some operational problems which may be encountered in the use of scrapers.

NOTE: As the operator gets more familiar with the techniques of using scraper, some of the following problems will disappear. Each operator will develop his or her own techniques of scraper operation over time.

Symptom	Problem	Solution
Scraper will not load properly	Tractor stalls	Load scraper in lower gear
		Raise scraper to reduce cutting depth
	Tractor Tires spin	Load scraper in higher gear
		Raise Scraper to reduce cutting depth
	Scraper gouges when loading	Load scraper in lower gear
		Raises scraper to reduce cutting depth
	Slow hydraulic pressure from low flow, low pressure, or foamy oil	Check hydraulic oil level. Refer to tractor operator manual.
		Check hydraulic oil filter(s) for clogging. Refer to tractor operator manual
		Adjust hydraulic oil flow through hydraulic remotes. Refer to tractor operator manual
		Increase engine RPM's
		Service hydraulic system. Refer to tractor operator manual
	Tractor is not getting maximum tractor from all tires	Refer to tractor's operator manual for scraper tractor ballast recommendation
	Cutting edge not biting	Check blades for wear, reverse the blades or replace if needed
		Lower scraper to increase cutting depth
	Cutting edge biting too much	Raise scraper to reduce cutting depth
Scraper loads slowly	Refer to operator's manual for different blade configuration to increase loading ability	
Scraper load size is not satisfactory or full after loading	In a deep cut situation, load scraper going downhill when possible	
	Alternate cut patters left to right, so that a ridge left behind by the frost	

Scraper will not load properly	Scraper load size is not satisfactory or full after loading	bit or stinger can be centered by a following load
		Lower center section of cutting edge into the frost bit or stinger position
		Cutting edge may be worn, reverse or replace the cutting edge
		Refer to tractor's operator manual for scraper tractor ballast recommendations.
Uneven or rough cut and fill areas	Scraper is duck walking or wash boarding	Cut deeper at slower speeds
		Check tire air pressure
		Lower or replace routers
		Start the cut deeper
	Loading heavy on one side	Check tire air pressure
	Load in a straight path	
	Rough fill areas	Eject material at grade or within 6 inches (15.24 cm) above the ground
Ejector or lift and lowering problems	Cylinders won't move	Check hydraulic quick-couplers
		Check hydraulic cylinders for leakage
		Check hydraulic remote setting for hydraulic flow, in tractor. Refer to tractor operator manual
		Check safety stops to make sure they are not in place
Apron and ejector cylinders moving at same time	Apron and ejector cylinder not in sequence	Refer to section 2.9.4 Sequence Apron and Ejector Valve for instructions

NOTES
