



**BRIDGEVIEW MFG. INC.**



## **2015 & 2016 Case IH 620 Quadtrac Ag Adapter Scraper Hitch**

### **Assembly Manual**

Last Updated: October 11, 2023

**Bridgeview Manufacturing Inc.**

P.O. Box 4

Gerald, Saskatchewan, Canada

S0A 1B0

Phone: 1-306-745-2711

Fax: 1-306-745-3364

Email: [bmi@sasktel.net](mailto:bmi@sasktel.net)

[www.bridgeviewmanufacturing.com](http://www.bridgeviewmanufacturing.com)

## 1 Parts Book

The following diagrams show the part numbers for ordering any replacement parts on a 2015 & 2016 Case IH 620 Quadtrac Ag Adapter Scraper Hitch. Some components may not look exactly as shown.

Quantities are listed for as shown. The diagrams should be referenced to find the part number, and order quantities should be based on what is required, not necessarily by the quantity on the table.

Left and right as used in the parts book is as viewed from the rear of the tractor looking in the direction of travel.

### 1.1 Adapter Assembly

1. Make sure drawbar pin on the tractor is in hole closer to the rear

Rear of Tractor

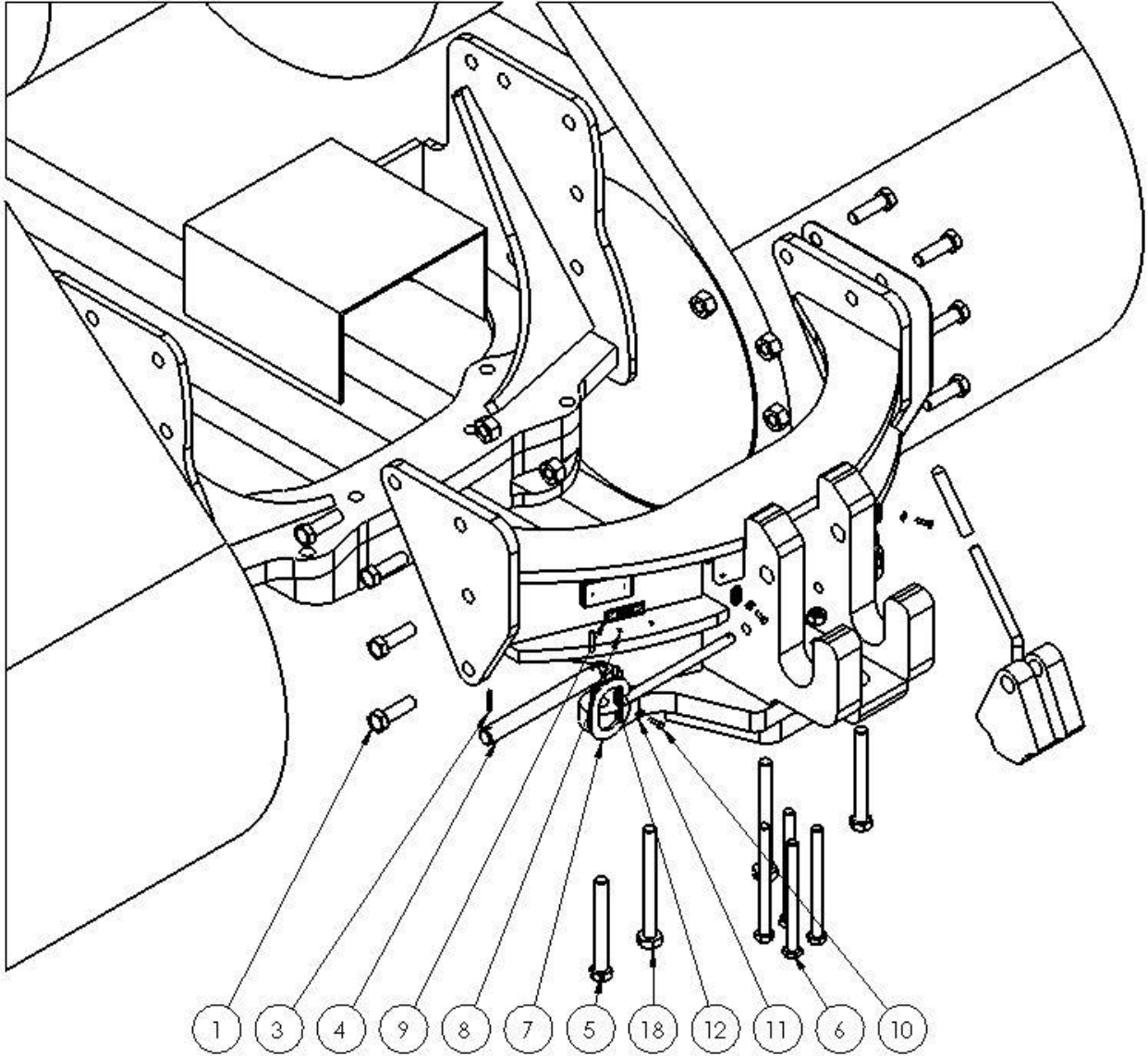

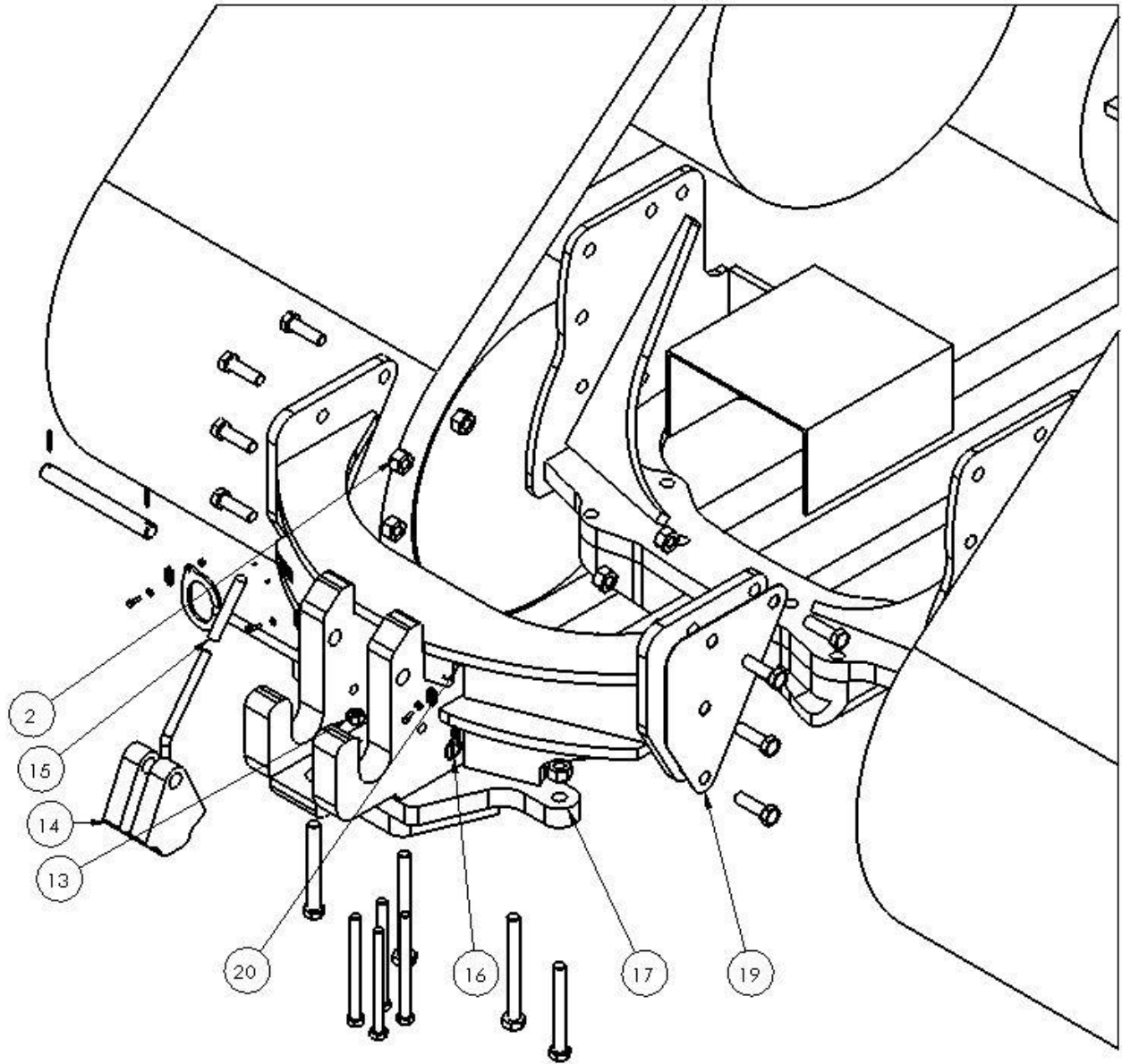

<b>Adapter Assembly</b>			
	<b>Description</b>	<b>ID #</b>	<b>QTY</b>
1	Bolt, M24 x 3 x 80 (Gr 10.9)	28590	8
2	Hex nut, M24 x 3 (Gr. 10.9)	28594	12
3	Roll Pin, ¼" x 1-3/4"	28589	2
4	Main Lock Shaft	28614	1
5	Bolt, M24 x 3 x 200 (Gr. 10.9)	28591	2
6	Bolt, M20 x 2.5 x 240 (Gr. 10.9)	28593	4
7	Lock Pin	28611	1
8	Pop rivet, 1/8" x ½"	27192	2
9	Serial Number Plate	-	1
10	Bolt, ¼" x 1"	11810	3
11	Flat washer, ¼"	11666	3
12*	Plated chain, 3/16" x 20"	11618	2
13	Hex nut, M20 x 2.5 (Gr. 10.9)	28595	4
14	Main Lock	28607	1
15	Rubber Handle	11796	1
16	Lynch Pin, 3/16" x 1-1/4"	13233	1
17	Main Adapter	28596	1
18	Bolt, M24 x 3 x 240	28592	2
19	Shim	28615	1
20	Nylon lock nut, ¼"	11664	3

\*Plated Chain is to be connected from main adapter (28596) to main lock shaft (28614) as well from main adapter (28596) to lynch pin (13233)

1.1.1 After Assembly

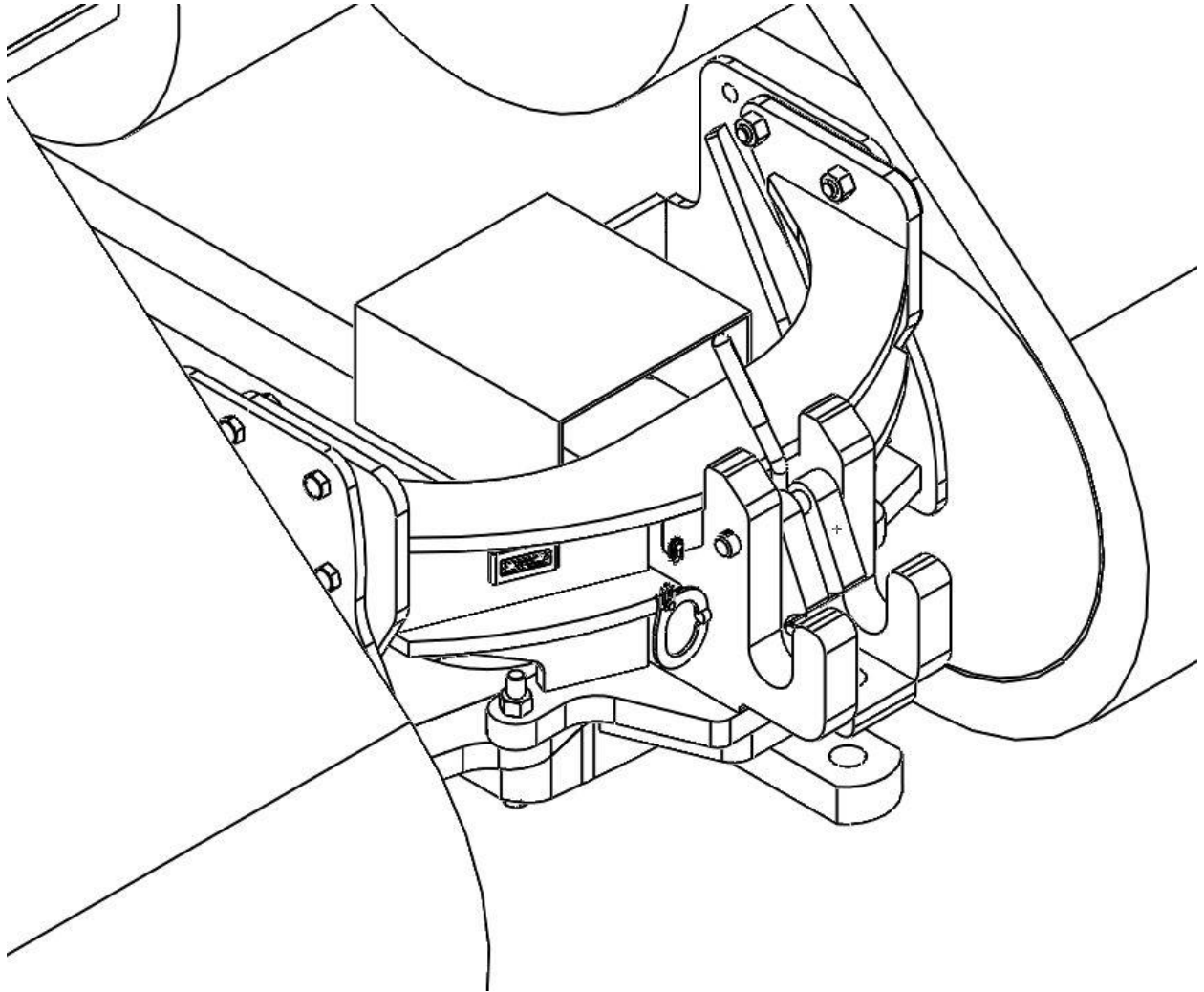

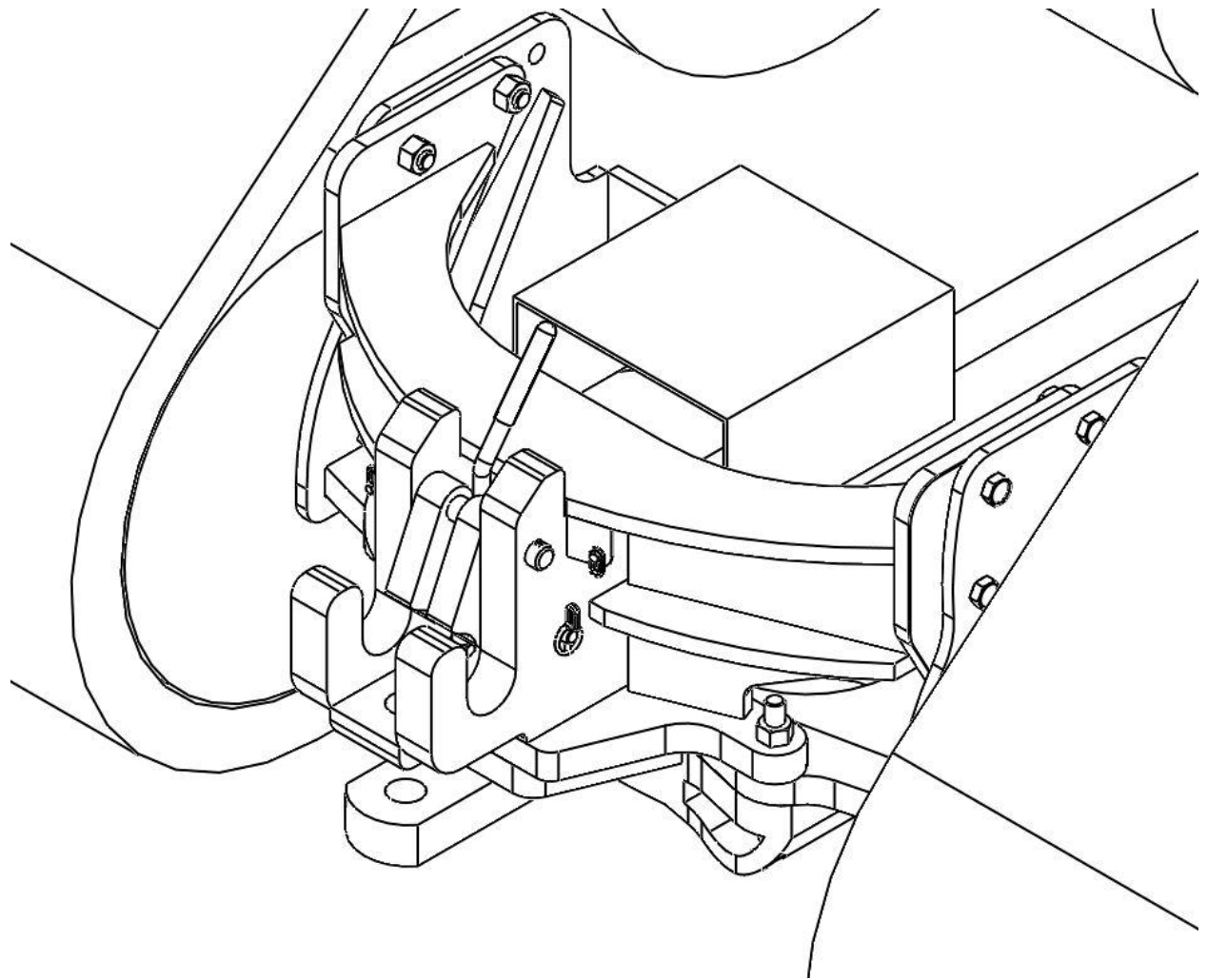



**Optional Scraper to Ag Adapter Category 4 (31401)**

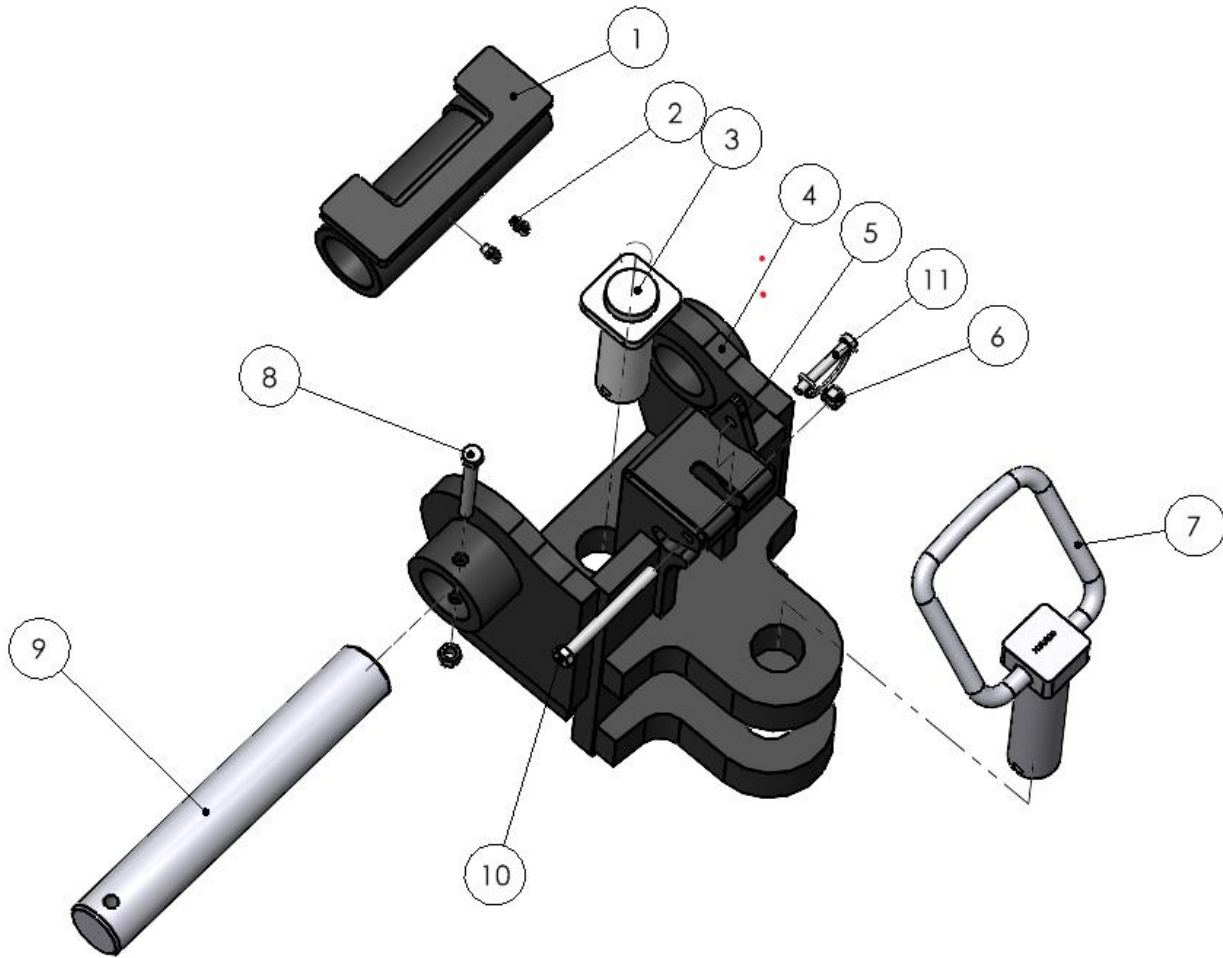

<b>Scraper to Ag Adapter Assembly</b>			
	<b>Description</b>	<b>ID #</b>	<b>QTY</b>
1	Scraper Adapter	28334	1
2	Grease Zerk, ¼-28 x 90°	16389	2
3	Case IH Ag Adaptor Pin	35219	1
4	Category 4 Scraper to Ag Adapter	31390	1
5	Ag Adapter Pin Stopper	31399	1
6	Nylon Lock Nut, ½"	10241	2
7	Category 4 Hitch Pin	31373	1
8	Bolt, ½" x 4-1/2"	15574	1
9	Ag Adapter Pin	31400	1
10	Bolt, ½" x 5"	15400	1
11	Lock Pin (3/8" x 2-3/16" Usable)	35219	1



**Optional Scraper to Ag Adapter Category 5 (35226)**

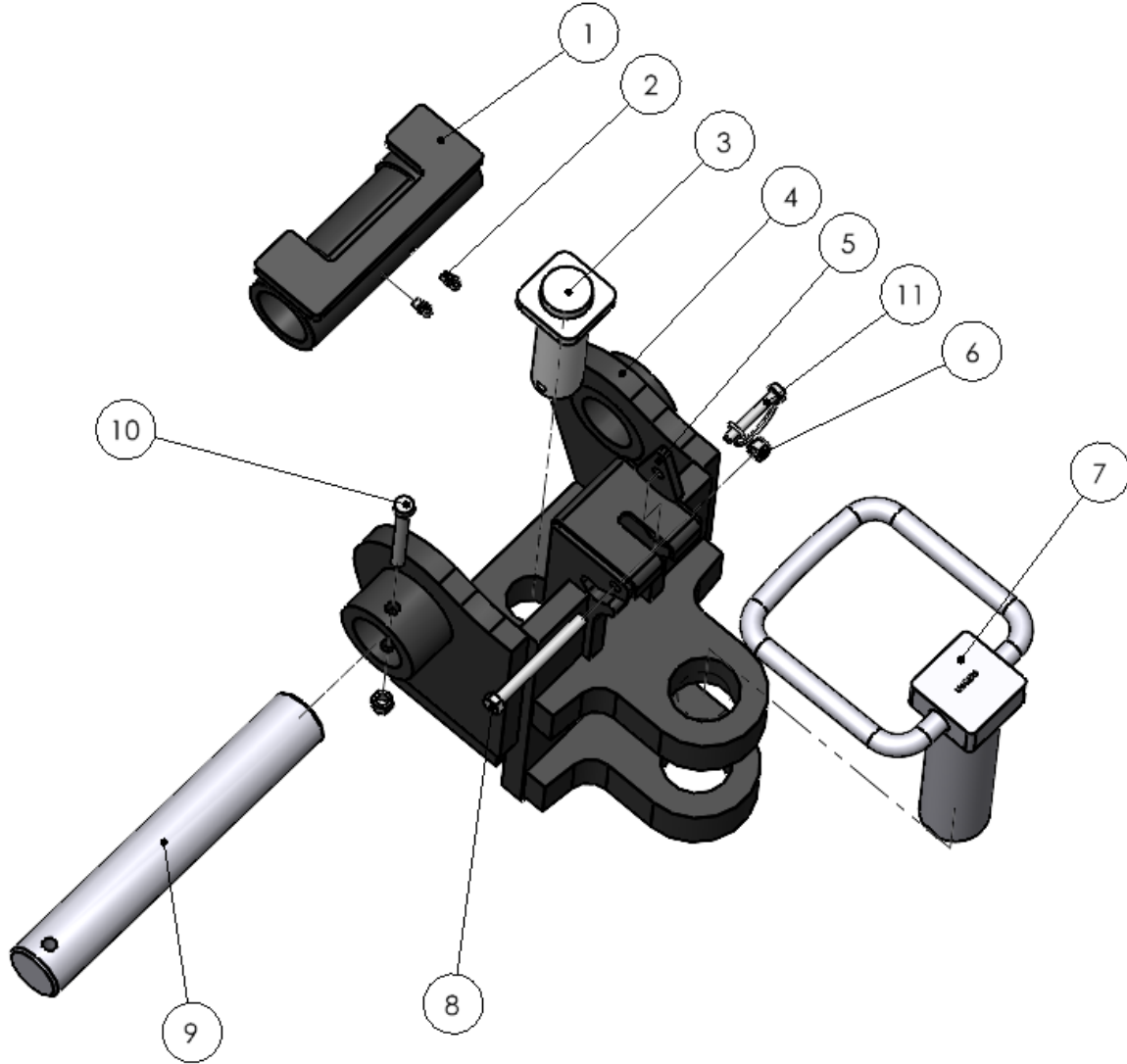

<b>Scraper to Ag Adapter Assembly</b>			
	<b>Description</b>	<b>ID #</b>	<b>QTY</b>
1	Scraper Adapter	28334	1
2	Grease Zerk, ¼-28 x 90°	16389	2
3	Case IH Ag Adaptor Pin	35219	1
4	Category 5 Scraper to Ag Adapter	35222	1
5	Ag Adapter Pin Stopper	31399	1
6	Nylon Lock Nut, ½"	10241	2
7	Category 5 Hitch Pin	31374	1
8	Bolt, ½" x 5	15400	1
9	Ag Adapter Pin	31400	1
10	Bolt, ½" x 4-1/2"	15574	1
11	Lock Pin (3/8" x 2-3/16" Usable)	35214	1

**Step 1**

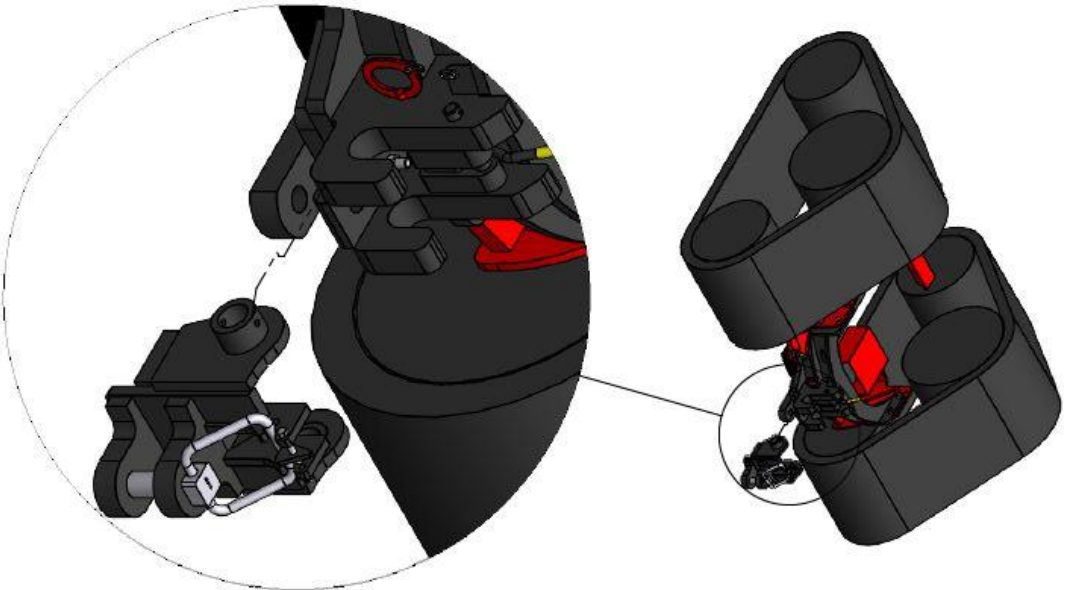

**Step 2**

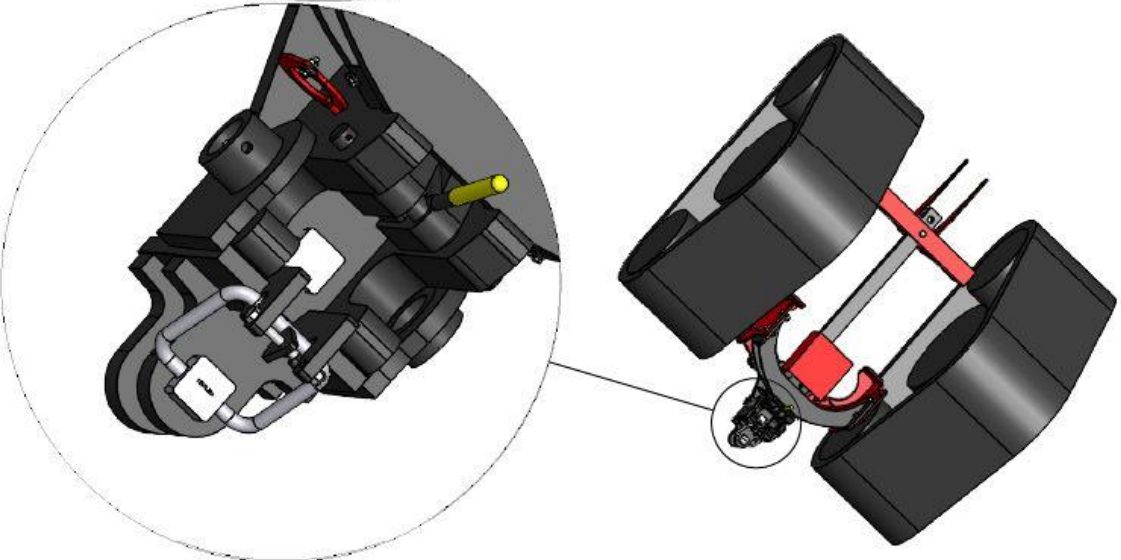

**Step 3**

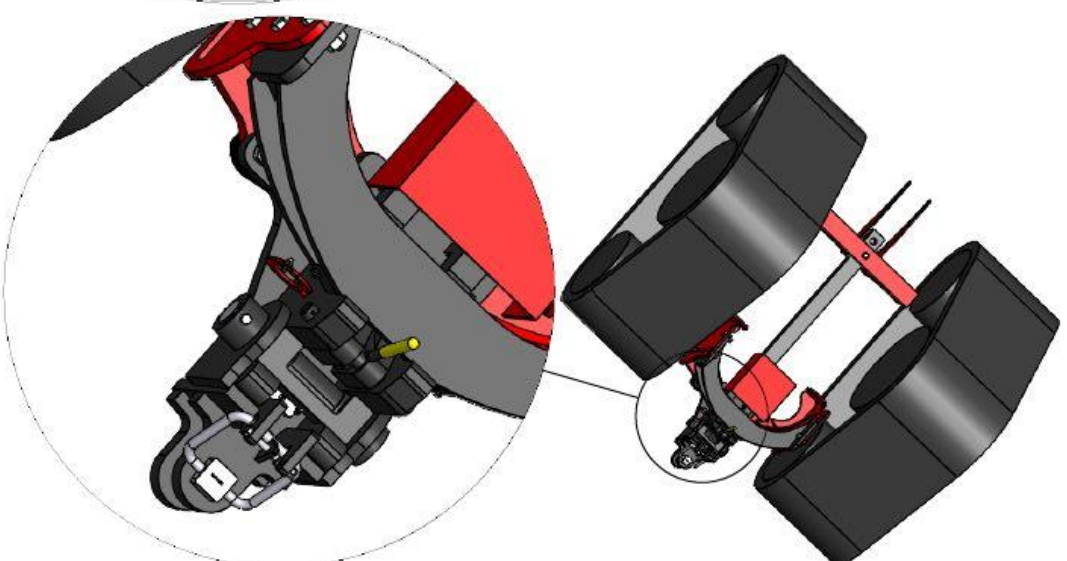

# FASTENER TORQUE CHARTS

	<b>BOLT CLAMP LOADS</b> Suggested Assembly Torque Values										
	USS/SAE GRADE 5					USS/SAE GRADE 8					
DIAMETER & THREADS PER INCH	TENSILE STRENGTH MIN. PSI	PROOF LOAD LB	CLAMP LOAD LB	TORQUE DRY FT LB	LUBRICATED FT LB	TENSILE STRENGTH MIN. PSI	PROOF LOAD LB	CLAMP LOAD LB	TORQUE DRY FT LB	LUBRICATED FT LB	
1/4-20 28	120,000	2,700	2,020	8	6.3	150,000	3,800	2,850	12	9	
	120,000	3,100	2,320	10	7.2	150,000	4,350	3,250	14	10	
5/16-18 24	120,000	4,450	3,340	17	13	150,000	6,300	4,700	24	18	
	120,000	4,900	3,700	19	14	150,000	6,950	5,200	27	20	
3/8-16 24	120,000	6,600	4,950	30	23	150,000	9,300	6,980	45	35	
	120,000	7,450	5,600	35	25	150,000	10,500	7,900	50	35	
7/16-14 20	120,000	9,050	6,780	50	35	150,000	12,800	9,550	70	50	
	120,000	10,100	7,570	55	40	150,000	14,200	10,650	80	60	
1/2-13 20	120,000	12,100	9,050	75	55	150,000	17,000	12,750	110	80	
	120,000	13,600	10,200	85	65	150,000	19,200	14,400	120	90	
9/16-12 18	120,000	15,500	11,600	110	80	150,000	21,800	16,350	150	110	
	120,000	17,300	12,950	120	90	150,000	24,400	18,250	170	130	
5/8-11 18	120,000	19,200	14,400	150	110	150,000	27,100	20,350	210	160	
	120,000	21,800	16,350	170	130	150,000	30,700	23,000	240	180	
3/4-10 16	120,000	28,400	21,300	260	200	150,000	40,100	30,100	380	280	
	120,000	31,700	23,780	300	220	150,000	44,800	33,500	420	310	
7/8-9 14	120,000	39,300	29,450	430	320	150,000	55,400	41,600	600	450	
	120,000	43,300	32,450	470	350	150,000	61,100	45,800	670	500	
1-8 14	120,000	51,500	38,600	640	480	150,000	72,700	54,500	910	680	
	120,000	57,700	43,300	720	540	150,000	81,500	61,100	1,020	760	

When using anti-seize, reduce the lubed chart reading by 20% to properly torque. Always lubricate and use lubed torque values.

Torques for Grades 5 and 8 were calculated based on the following relationship:

$$T = R D P$$

Where: T = Torque (ft lb)

D = Nominal Diameter (in)

P = Clamp Load (lb)

R = Tightening Coefficient

The value of R is assumed to be equal to .20 for dry, unplated conditions and equal to .15 for lubricated, including plated, conditions. Actual values of R can vary between .05 and .35 for commonly encountered conditions.

**NOTES:**

The above recommended assembly torques are offered as a guide only. Torque specifications, especially for critical joints, should be determined under actual assembly conditions due to the many variables involved which are difficult to predict and do affect the torque-tension relationship.

The above recommended clamp loads are based on 75% of the minimum specified proof loads for each grade and size.

STRENGTH GRADE	APPLICABLE SIZES	PROOF LOAD STRESS (PSI)	YIELD STRENGTH MIN. STRESS (PSI)	TENSILE STRESS MIN. (PSI)
SAE Gr. 5	1/4 to 1" diameter over 1" diameter to 1-1/2 diameter	85,000	92,000	120,000
		74,000	81,000	105,000
SAE Gr. 8	1/4 to 1" diameter	120,000	130,000	150,000

Pounds to Inch Pound Conversion

lb x 12 = inch lb

Example: 9 lb x 12 = 108 inch lb

Imperial has made a concerted effort to provide accurate information in its catalog and on its website, however Imperial assumes no responsibility for the accuracy of the information. All information published by Imperial in its catalogs, marketing literature, and on its website is provided "as is" without warranty, expressed or implied. Imperial and its vendors disclaim all warranties, expressed or implied including, without limitation, warranties of merchantability and fitness for a particular purpose.

FRACTIONAL MEASUREMENT		
BOLT DIAMETER	CAP SCREW WRENCH SIZE	NUT WRENCH SIZE
1/4	7/16	7/16
5/16	1/2	1/2
3/8	9/16	9/16
7/16	5/8	11/16
1/2	3/4	3/4
9/16	13/16	7/8
5/8	15/16	15/16
3/4	1-1/8	1-1/8
7/8	1-5/16	1-5/16
1"	1-1/2	1-1/2
1-1/8	1-11/16	1-11/16
1-1/4	1-7/8	1-7/8
1-3/8	2-1/16	2-1/16
1-1/2	2-1/4	2-1/4
1-3/4	2-5/8	2-5/8
2"	3"	3"
2-1/4	3-3/8	3-3/8
2-1/2	3-3/4	3-3/4
2-3/4	4-1/8	4-1/8
3"	4-1/2	4-1/2



# FASTENER TORQUE CHARTS

GUIDE FOR PREVAILING-TORQUE LOCK NUT ASSEMBLY TORQUES (CAD AND WAX, GRADE B, C, AND GRADE G FLANGE NUTS) LOCK NUT STANDARDS FROM IFI-100 REQUIREMENTS

Torque-Tension Requirements

Size Threads Per Inch	GRADE B			GRADE C			GRADE G		
	CLAMP LOAD (Lb)	ASSEMBLY TORQUE MAX.	MIN.	CLAMP LOAD (Lb)	ASSEMBLY TORQUE MAX.	MIN.	CLAMP LOAD (Lb)	ASSEMBLY TORQUE MAX.	MIN.
1/4-20	2,000	85**	60**	2,850	125**	85**	2,850	150**	100**
1/4-28	2,300	90**	65**	3,250	125**	85**	3,250	160**	105**
5/16-18	3,350	150**	110**	4,700	190**	130**	4,700	240**	155**
5/16-24	3,700	160**	120**	5,200	200**	140**	5,200	230**	155**
3/8-16	4,950	20	14.5	6,950	28	20	6,950	32	21
3/8-24	5,600	22	16	7,900	29	21	7,900	33	22
7/16-14	6,800	32	23	9,600	43	31	9,600	51	34
7/16-20	7,550	34	24	10,700	43	31	10,700	60	40
1/2-13	9,050	50	37	12,800	62.5	45	12,800	85	55
1/2-20	10,200	52.5	37.5	14,440	70	50	14,440	89	59
9/16-12	11,600	70	50	16,400	95	70	16,400	120	80
9/16-18	13,000	77.5	57.5	18,300	95	70	18,300	132	88
5/8-11	14,500	95	70	20,300	122.5	90	20,300	143	95
5/8-18	16,300	97.5	72.5	23,000	125	90	23,000	175	115
3/4-10	21,300	165	125	30,100	210	155	30,100	240	160
3/4-16	23,800	165	120	33,600	210	155	33,600	270	170
7/8-9	29,500	250	185	41,600	312.5	225	41,600	360	260
7/8-14	32,400	270	200	45,800	312.5	225	45,800	402	247
1-8	38,700	375	275	54,600	462.5	360	54,600	530	410
1-12	42,300	395	290	59,750	490	360	59,750	—	—
1-14	43,000	400	300	61,100	500	362.5	61,100	645	398
1-1/8-7	42,100	404	294	69,000	585	454	69,000	—	—
1-1/8-12	47,500	437	327	76,800	622	453	76,800	—	—
1-1/4-7	53,500	513	375	87,000	736	573	87,000	—	—
1-1/4-12	59,700	549	412	96,600	782	570	96,600	—	—
1-3/8-6	63,800	612	445	104,000	880	685	104,000	—	—
1-3/8-12	72,900	670	503	118,000	955	696	118,000	—	—
1-1/2-6	77,600	745	545	127,000	1,075	837	127,000	—	—
1-1/2-12	87,700	807	605	142,000	1,150	837	142,000	—	—

- Clamp loads for the Grade B lock nuts equal 75% of the bolt proof loads specified for SAE J-429 Grade 5, and ASTM A-449 bolts.
- Clamp loads for Grade C lock nuts equal 75% of the bolt proof loads specified for SAE J-429 Grade 8, and ASTM A-354 Grade BD bolts.
- IFI-100 does not govern lock nuts above 1". The values shown in the chart are to be used as a mid-range guideline.
- \*\* Torque values for 1/4" and 5/16" sizes are in inch lb. All other torque values are in foot lb.

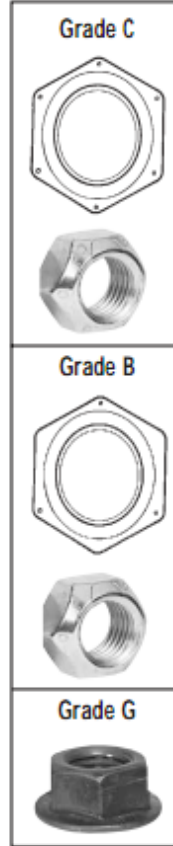

## METRIC TORQUE CHART FOR HEX HEAD CAP SCREWS

Size	CLASS	NEWTON METERS		FOOT POUNDS (APPROX.)		CLASS
		ZINC PLATED	UNPLATED	ZINC PLATED	UNPLATED	
M4 x .70 Pitch	8.8	3.1	2.2	2.30	1.65	8.8
M5 x .80 Pitch	8.8	6.1	5.5	4.58	4.13	
M6 x 1.00 Pitch	8.8	10.4	9.5	7.80	7.13	
M7 x 1.00 Pitch	8.8	17.0	15.5	12.75	11.63	
M8 x 1.25 Pitch	8.8	25.0	23.0	18.75	17.25	
M8 x 1.00 Pitch	8.8	27.0	24.5	20.25	18.38	
M10 x 1.50 Pitch	8.8	51.0	46.0	38.25	34.50	
M10 x 1.00 Pitch	8.8	57.0	52.0	42.75	39.00	
M10 x 1.25 Pitch	8.8	54.0	49.0	40.50	36.75	
M12 x 1.75 Pitch	8.8	87.0	79.0	65.25	59.25	
M12 x 1.25 Pitch	8.8	96.0	87.0	72.00	65.25	
M12 x 1.50 Pitch	8.8	92.0	83.0	69.00	62.25	
M14 x 2.00 Pitch	8.8	140.0	125.0	105.00	93.75	
M14 x 1.50 Pitch	8.8	150.0	135.0	112.50	101.25	
M16 x 2.00 Pitch	8.8	215.0	195.0	161.25	146.25	
M18 x 2.50 Pitch	8.8	300.0	280.0	225.00	210.00	
M20 x 2.50 Pitch	8.8	430.0	390.0	322.50	292.50	
M22 x 2.50 Pitch	8.8	580.0	530.0	435.00	397.50	
M24 x 3.00 Pitch	8.8	740.0	670.0	555.00	502.50	
M6 x 1.00 Pitch	10.9	15.5	14.0	11.63	10.50	10.9
M8 x 1.25 Pitch	10.9	37.0	34.0	27.75	25.50	
M10 x 1.50 Pitch	10.9	75.0	68.0	56.25	51.00	
M12 x 1.75 Pitch	10.9	160.0	117.0	97.50	87.75	
M14 x 2.00 Pitch	10.9	205.0	185.0	153.75	138.75	
M16 x 2.00 Pitch	10.9	310.0	280.0	232.50	210.00	

## TORQUE CHART FOR STAINLESS STEEL CAP SCREWS

SIZE	316 INCH-LB	18/8 INCH-LB
6-32	10.1	9.6
6-40	12.7	12.1
8-32	20.7	19.8
8-36	23.0	22.0
10-24	23.8	22.8
10-32	33.1	31.7
1/4-20	78.8	75.2
1/4-28	99.0	94.0
5/16-18	138.0	132.0
5/16-24	147.0	142.0
3/8-16	247.0	236.0
3/8-24	271.0	259.0
7/16-14	393.0	376.0
7/16-20	418.0	400.0
1/2-13	542.0	517.0
1/2-20	565.0	541.0
9/16-12	713.0	682.0
9/16-18	787.0	752.0
5/8-11	1,160.0	1,110.0
5/8-18	1,301.0	1,244.0
3/4-10	1,582.0	1,530.0
3/4-16	1,558.0	1,490.0
7/8-9	2,430.0	2,328.0
7/8-14	2,420.0	2,318.0
1"-8	3,595.0	3,440.0
1"-14	3,250.0	3,110.0

PHONE: 1-800-558-2808

FAX: 1-800-553-8769

WEB: [www.imperialsupplies.com](http://www.imperialsupplies.com)

