



**BRIDGEVIEW MFG. INC.**



## *Bale King 6105*

*Bale processor*

### **OPERATOR & PARTS MANUAL**

Last Updated: January 2017



BRIDGEVIEW MANUFACTURING INC  
P.O BOX 4, HWY 22  
GERALD, SASK. S0A 1B0  
CANADA  
Ph: 306-745-2711  
Fax: 306-745-3364  
Email: [bmi@sasktel.net](mailto:bmi@sasktel.net)  
[www.bridgeviewmanufacturing.com](http://www.bridgeviewmanufacturing.com)

**Your Authorized Dealer**

**Your Serial Number**

The Serial Number is located near the front of the left hand wall of the tub.



**⚠ WARNING**

**Failure to read and understand operator's manual & all safety signs could result in serious injury. Manual must remain with machine.**



# TABLE OF CONTENTS

<b>TABLE OF CONTENTS</b>	<b>ii</b>
<b>Introduction</b>	<b>5</b>
<i>Safety Precautions</i>	5
<i>Safety Decals</i>	6
Power Take off	6
Discharge	7
<b>Features</b>	<b>8</b>
<i>Power Take-Off</i>	8
<i>Shear bolt</i>	9
<i>PTO Holder</i>	9
<i>Hydraulics</i>	9
<i>Implement Tongue</i>	10
<i>Loading fork</i>	11
<i>Hoop Grate Adjustment</i>	11
<i>Processing Tips</i>	12
<i>Deflector</i>	13
<i>Agitators</i>	15
<i>Optional Fine Chop Kit</i>	15
<i>Loading deck</i>	16
<i>Torflex axles</i>	16
<b>Safety Operation</b>	<b>16</b>
<i>Power and take off Use</i>	16
Length	16
Shielding	16
Working Angle	17
Attachment	17
Storage	17
<i>Hook up the machine</i>	17
<i>Loading the processor</i>	18
<i>Processing bale</i>	19
<i>Unhook the machine</i>	19
<i>Twine Removal</i>	19
<b>Maintenance and trouble shooting</b>	<b>20</b>
<i>Power take-off</i>	20
PTO Shield	20
Shield Assembly	20
Verification on the shield	20



Greasing the PTO shaft	21
<i>Gearbox</i>	21
<i>Hydraulics</i>	22
Hydraulic hose	22
Hydraulic cylinder	22
<i>Wheels and tires</i>	22
Hub Removal	22
Bearing and seal inspection	23
Hub installation	23
Tires	23
<i>Feeding Chain</i>	24
Chain Adjustment Procedure	24
<i>Twine Removal</i>	24
<i>Flail and bushing Replacement</i>	25
<i>Transportation</i>	26
<i>Greasing location</i>	27
<i>Troubleshoot guide</i>	28
<b>Features and Specifications</b>	<b>29</b>
<b>Parts manual</b>	<b>30</b>
<i>Upper Tub</i>	31
<i>Agitators</i>	32
<i>Hoop Grate and Handle</i>	34
<i>Rotor and twine cutter</i>	35
10" 28 Flail X Rotor	36
Gearbox Assembly	37
Twine Cutter	39
<i>Complete PTO Assembly, Weasler Cat. 6</i>	40
<i>PTO Holder and Manual</i>	41
<i>Hitch</i>	41
<i>Deflector</i>	42
<i>Axles</i>	45
<i>Main deck</i>	46
<i>Slow Moving Vehicle Sign</i>	47
<i>Idler Wheel Assembly</i>	48
<i>Chain Motor Assembly</i>	50
<i>Loading fork</i>	51
<i>Fine chop</i>	52
<i>Decal</i>	54



<b>Hydraulics &amp; Wiring Diagram</b>	<b>56</b>
<i>Conveyor Chain Motor</i>	58
<i>Tilt/Fork/Deflector</i>	59
	<b>59</b>
<i>Diverter Diagram</i>	63
Machine side	63
Tractor Side (Control Box #23988)	63
<b>Notes</b>	<b>65</b>



## Introduction

Thank you for purchasing the Bale King 6105 Bale processor by Bridgeview Manufacturing. By following the instructions in this manual, the Bale King will provide you with years of trouble free operation.

This document is a complete safety, operation and parts manual for the Bale King 6105. The manual explains how to safely and effectively use your bale processor. The procedures outlined in this manual must be followed to ensure safe operation and longevity of your machine. The parts section of this manual lists all the parts you may need to order in case of accident or breakdown.

### Safety Precautions

The following safety precautions **MUST** be followed to ensure safe operation of the Bale King bale processor.

- **ALWAYS** turn off the PTO when leaving the operating platform.
- **DO NOT** stand in front of the discharge chute while the machine is in operation. Projectiles can travel up to 50m.
- **DO NOT** walk or move under the bale forks unless the cylinder safety lock is in place.
- **DO NOT** enter the machine while in operation.
- **DO NOT** clean the machine while in operation.
- **DO NOT** stick any device into the machine to clear debris while the machine is in operation.
- **ALWAYS** turn off the machine when cleaning the machine, removing twine, or hooking/unhooking the machine
- **ALWAYS** use the provided road safety chains when towing the machine on a public road.
- **DO NOT** operate the machine if any part of the **PTO safety shielding** is missing or is not secured.



## Safety Decals

### Power Take off

The operator must obey all safety labels and must ensure the original shielding remains in place. A high percentage of drive-line injuries occur when safety shielding is missing or not functioning properly.

**! DANGER**



**ROTATING PTO DRIVELINE HAZARD**

To prevent serious injury or death:

- Keep body, hair, and clothing away from rotating PTO driveline.
- Do not operate equipment unless all driveline, tractor, and equipment shields are in place and in good working order.
- Make certain the driveline shields turn freely on driveline.
- Make certain the driveline is securely attached at both ends.
- Do not exceed operating speed of 1000 rpm.
- Keep u-joint angles small and equal. Do not exceed maximum recommended length for PTO driveline.

Made in Canada
12219



399CEE072



399CEE051



**DANGER:** *Contact with a rotating drive-line can cause serious injury or death.*





*Discharge*

*Do not stand on the discharge side of the machine while it is in operation.*



*Stand clear of lift area. Do not stand under the forks unless safety locks are installed.*







## Features

### Power Take-Off



The Bale King processor has a PTO shaft that is splined on both ends. The implement end of the shaft uses a 1-3/4"-20 spline with wedge lock bolts. Install onto the gearbox and tighten the wedge bolts. The bolts must be tightened to **160 ft-lb of torque** and **must be re-tightened after 8 hrs. of use.**

The tractor end of the PTO shaft is a 1-3/8"-21 spline quick detach constant velocity joint. An optional 1-3/4"-20 spline yoke is available through your Bale King dealer.

The Bale King processor is designed to use a minimum of **100 HP**. The drive shaft is shear-bolt protected. The machine must be operated at **1000 PTO RPM**. **Idling back can cause premature wear to rotor.**



*Spread yokes and twisted drive shafts are signs of overload, not a manufacturer's defect and therefore not covered by warranty.*

**DO NOT** operate the machine using a spline adaptor. Use of adaptors will **void warranty** due to damage caused to the tractor PTO, PTO driveshaft, or implement.

**DO NOT** operate at 540 rpm, or use any kind of adaptor to connect to a 540 rpm spline.

**Always** ensure that the PTO shaft is attached securely to the tractor. When the processor is not hooked to the tractor, secure the shaft to the PTO holder.

**DO NOT** transport the processor without securing the PTO shaft. It may bounce off the holder and be damaged.

**Always** ensure that the tractor drawbar is adjusted to **16"** from the end of the tractor PTO shaft to the center of the hole in the drawbar.



## Shear bolt

The Bale King is equipped with a **shear bolt** clutch located at the implement end of the PTO shaft. The correct size shear bolt is **3/8"x2" Gr.5**. Any other size or grade will **damage** the shear assembly. Spare shear bolts are included with the machine and are stored along the front top lip of the tub.

If the shear-bolt breaks often you may be over-loading the machine. If this occurs raise the grate assembly for a less aggressive cut, or roll the bale more slowly. **Always ensure that your machine is running at 1000 PTO RPM.**

NOTE: Please consult your local dealer to help pinpoint any problems.

## PTO Holder

Always store the PTO shaft in the holder when the processor is not in use.

Proper storage of the shaft in the holder keeps the shaft away from the hitch when hooking the tractor to the machine and prevents it from becoming damaged by snow, ice and debris.

The hydraulic hoses may need to be adjusted to best fit your tractor, to avoid damage from rubbing on the PTO shaft shield. This can be done by loosening the bolt on top of the plastic hose clamp, then pushing or pulling on the hoses to adjust the length, and retightening the bolt.



## Hydraulics

*Pressurized hydraulic fluid can cause serious injury.*

- When working with hydraulic equipment, eye and hand protection must be worn.
- Do not test for leaks with bare hands.
- Relieve all pressure before removing a hose or fitting.
- Never work under components supported by hydraulic cylinders (forks, side discharge chute, deck) without hydraulic cylinder safety locks in place.



To operate the Bale King each of the 6 hydraulic hoses on the processor must be connected to the hydraulic remotes on the tractor. Each pair must be connected to the same hydraulic remote.



**CAUTION:** *If a hydraulic pair is connected to two separate remotes, the Bale King 6105 will not function properly.*

The hoses are color coded for easy identification:

HOSE COLOR AND SIZE	CONTROLS
<b>RED</b> LARGE	AGITATORS
<b>YELLOW</b> LARGE	CONVEYOR CHAIN
<b>BLUE</b> SMALL	DEFLECTOR/FORKS/DECK



**WARNING:** *Excessive oil flow may damage the flow divider cartridge. Always set the tractor's hydraulic flow at a low rate and adjust it to a higher rate until the desired speed is reached.*

### Implement Tongue

The adjustable hitch on the Bale King is a cast single tongue with hammer strap insert. It can be attached to a tractor equipped with a hammer strap or with a single drawbar. The design of the tongue allows the machine to move over rough terrain without bending the draw pin.

**ATTENTION:** Set the drawbar to **16 inches** behind the PTO shaft to ensure proper PTO length. Adjust the hitch height to equal the height of the drawbar. When the hitch height is properly adjusted the machine should sit level with the tractor. If the machine is not level while attached to the tractor, hitch adjustment is required.



## Loading fork



The loading fork on the Bale King 6105 can handle up to 6.5ft bale. The loading fork is designed to load bales into the tub while the deck is inclined or flat. The fork design allows an operator to load all six bales without repositioning the bed tilt.

## Hoop Grate Adjustment

The hoop grate adjustment controls the rate of feed and cut of processed material. There are six adjustment settings for the hoop grate on the Bale King processor:





Use the following table to set the hoop grate for bale type, condition and desired cut.

HOOP GRATE ADJUSTER POSITION	CUT	RATE OF FEED	BALE TYPE/CONDITION
Less Aggressive	FINE	SLOW	Silage Bales, Damp/Tough Hay Bales, Green Feed, Flax.
Middle	REGULAR	MEDIUM	Dry Hay Bales
More Aggressive	COARSE	FAST	Dry Straw



### Processing Tips

- 1.5 to 2.5 minutes is considered normal processing time for the Bale King 6105.
- Light brittle material like wheat straw may process faster. Tough bale material like slough hay, green feed, or flax requires slower processing. Hoop grate adjustment should be checked regularly.
- Processing a bale too rapidly may cause excessive wear and tear.
- Upper grate position should be approximately 1/4" flail recession. Lower grate position should allow 1-1/2" flail protrusion. Contact your Bale King dealer if this can't be achieved.
- Excessive vibration of machine is an indication that the bale is being processed too rapidly. To remedy this, either raise the hoop grate or slow down the agitators.



## Deflector

The 6105 series Bale King is equipped with a hydraulic side deflector to change the output distance and distribution of the hay. It also comes with a flipping rubber flap for superior control of the spread pattern.

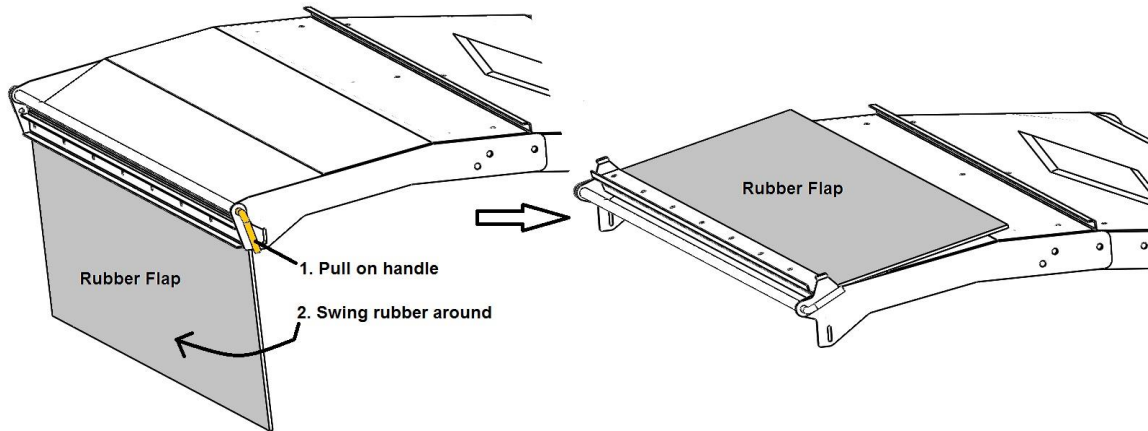

Moving the deflector to the down position and flipping the rubber down (above left) will allow the hay to be laid in a windrow, or bunk feeder. Swinging the deflector up will allow you to spread straw out over a large area. If you also flip the rubber up (above right), you will be able to "fine tune" the discharge, to control the height and distance.

To flip the rubber, simply pull on the handle and swing into position. Then push the handle so that the tabs catch in the notches and lock into place.

- For transport and storage, the deflector lock must be put in place by moving the deflector into the full upright position. Place the deflector lock over the pins on the deflector and processor then affixing the clips to secure the lock to the processor.

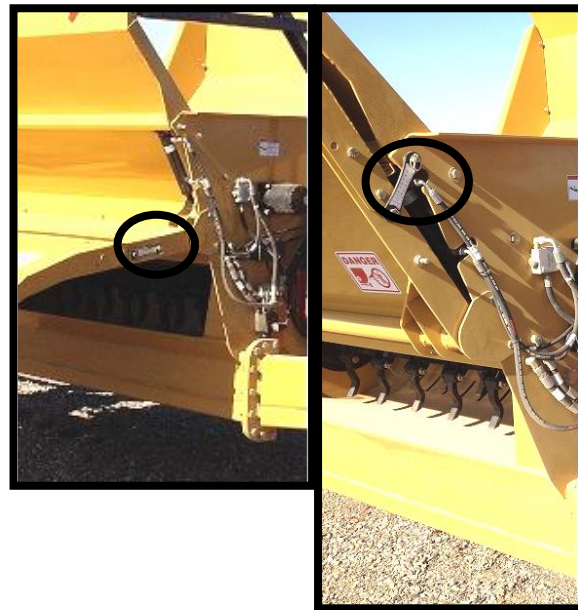

The Bale King 6105 deflector length is adjustable. To adjust deflector length:

- Move the deflector the lowest position.
- Remove seven bolts (2 front, 3 top, 2 rear) connecting the inner and outer deflector pieces.



- Slide the outer deflector to the desired width and replace and tighten the bolts.

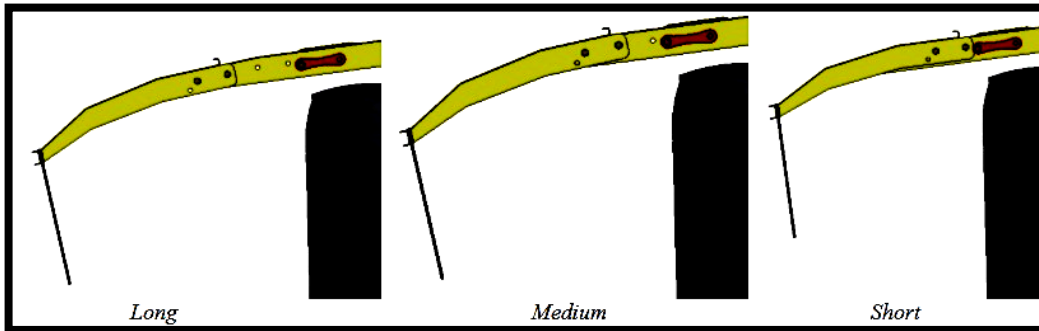

There are three (3) deflector length positions for processing. For storage and transport the deflector can be folded in half.

	<b>Bunk Feeding Width (Distance from Tire)</b>	<b>Transport Width Total (RHS, LHS)</b>
Folded	n/a	8'-6" (4'-3", 4'-3")
Short	28 Inches	9'-4" (5'-1", 4'-3")
Medium	32 Inches	9'-8" (5'-5", 4'-3")
Long	35 Inches	9'-10" (5'-7", 4'-3")

To secure the deflector in the folded position safely two people are required as the deflector is heavy. To secure the deflector in the folded position:

- Using the hydraulic controls move the deflector to its lowest position
- Remove the seven bolts (2 front, 3 top, 2 rear) connecting the inner deflector and outer deflector
- Support the outer deflector and move it to the widest setting. Replace the bolts on the front and back of the deflector as shown (do not tighten yet, do not replace top bolts)
- Raise the deflector to its highest position using the hydraulic controls.
- Remove the bolts closest to the machine center (both front and back) and swing the outer deflector down.

Be sure that the outer deflector fits outside the tub walls. Some adjustment may be required for it to fit. Replace the bolts on the front and back in the available holes as shown. The deflector should now fit inside the width of the processor.



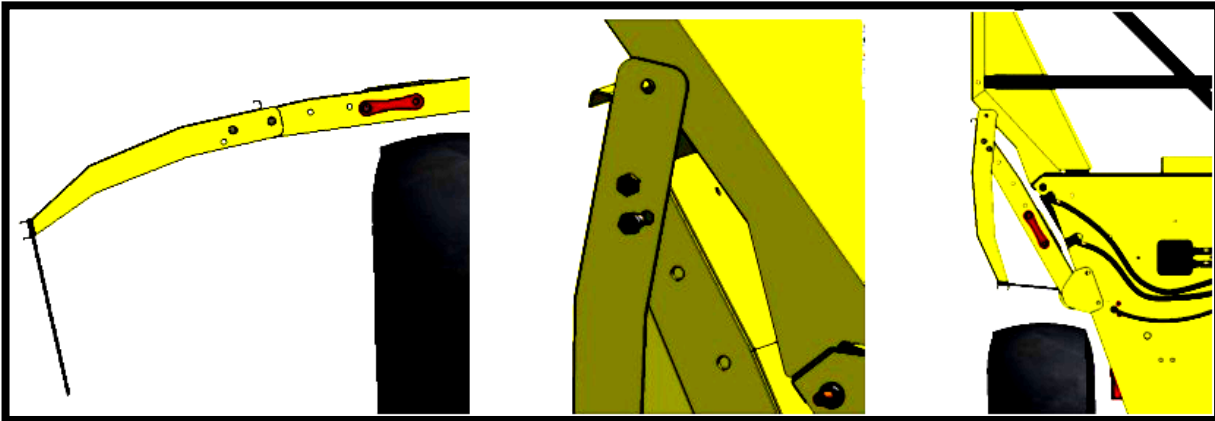

## Agitators

The Bale King is equipped with two hydraulic motor driven agitators to turn the bale.

The agitators must rotate the bale continuously for smooth processing. Reverse rotation if loose debris builds up on either side of the bale chamber. By reversing direction regularly, soft core bales will process more evenly.



*Adjust your tractor's flow control speed to about 34 RPM. Fine tune from 34 RPM to achieve desired processing speed.*

## Optional Fine Chop Kit

The Bale King has an optional fine chop knife kit available to go on the lower tub area. This option is available if you require a fine cut on the material which you are processing such as slough hay and silage bales.

It is recommended that the knives be lowered when bedding straw. Adjust the machine as needed.

There are two settings for the fine chop, depending on how fine you wish to cut the material. These settings achieved by pulling on the handle (towards the back of the machine), then selecting the desired hole.





## Loading deck

The Bale King 6105 can carry 5 bales on the deck and 1 bale inside the tub. It is equipped with a pair of heavy duty conveyor chains to load bales. Set the flow rate on the tractor for the desired loading speed.



## Torflex axles

The Bale King is equipped with a pair of Torflex axles that allow a smooth ride over rough terrain. .

## Safety Operation



### Power and take off Use

*Prior to first use of the Bale King, the PTO connectors and shaft length must be adjusted to your tractor.*

#### *Length*

Confirm the minimum and maximum working lengths of the drive-line. The telescoping tubes must overlap at least 1/3 of their length when in use. The PTO is designed to be used with a drawbar length of 16" from the end of the PTO shaft. Adjust your tractor accordingly.

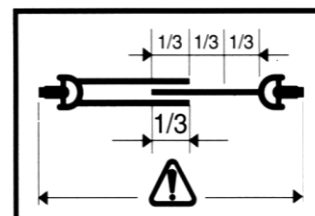

#### *Shielding*

Be sure that the shielding is not damaged and rotates freely on the drive shaft.





### **Working Angle**

*Constant Velocity joints can operate up to 80 degrees for short periods of time. Do not operate for long periods on sharp angles.*

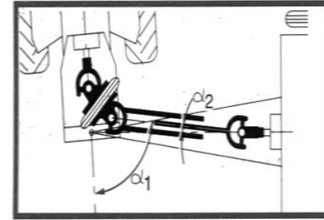

### **Attachment**

Be sure the drive-line is properly attached and all bolts and screws are tight on the implement input shaft and on the tractor PTO shaft



### **Storage**

When not in use, cover or protect the drive shaft from the the elements. When removed from the machine store both halves together to prevent damage. Check all components for proper function and lubrication before use.



### **Hook up the machine**

1. Connect Bale King to tractor drawbar
2. Shut OFF the tractor.
3. Hook up PTO, hydraulic hoses, light plug and the electrical harness into the control box.
4. Remove the jack stand and attach it to the storage jack stub located on the left side of the machine.
5. Attach the safety chain to a secure and safe location on the tractor.
6. Visually inspect and verify that the tractor and processor are safe to operate. Perform any required performance checks to ensure the equipment will operate as expected.



## Loading the processor

To load bales on the processor:

1. Position the processor so the back of the deck is aligned with the center of the bale(s) you wish to load.
2. Raise the deck until the skid shoe gently touches the ground.
3. Back slowly under the row of bales and rotate the conveyor chain to draw the bales up the deck, matching tractor speed to the chain speed. Let the chain run until the first bale reaches end of the deck.
4. Stop rotating the chain and load the first bale into the tub with the fork.
5. Rotate the conveyor chain to draw bales up onto the deck while backing slowly under the row of bales.
6. Lower the fork to its home position before you load the deck with the final bale.
7. Lower the deck when the final bale is loaded. Allow tractor to roll forward as you lower the deck.

**TIP: Once first bale is on the deck, lower deck slightly to minimize twine build-up on the rear pulley.**





## Processing bale

Set hoop grate according to the table on page 11. Adjust fine chop if your machine is equipped with it.

1. Engage the PTO when the tractor is idle.
2. Raise PTO speed to 1000 RPM
3. Set deflector: - Bedding – deflector fully raised / Windrow – deflector fully lowered
4. Rotate bale with agitators left or right. Reverse directions periodically to ensure even processing. (Approx agitator speed is 32 – 34 RPM).

## Unhook the machine

Shut OFF the tractor and remove the key before unhooking the machine.



*Make sure the processor is empty to prevent damage to the hitch jack.*

1. Support the processor with the hitch jack.
2. Unhook hydraulics, electrical harnesses and the PTO shaft. Arrange them on PTO holder.
3. Remove hitch pin.

## Twine Removal

- Twine or net wrap should be removed after approximately 25 bales.
- Excessive twine build-up may hinder flail operation, can cause rotor imbalance and will make removal more difficult.





## Maintenance and trouble shooting

This section drives you through some maintenance, troubleshooting tips.

**BEFORE ATTEMPTING ANY REPAIR PROCEDURES,  
ALWAYS USE APPROPRIATE EQUIPMENT SUCH AS  
SAFETY GLASSES, SAFETY SHOES, AND GLOVES**

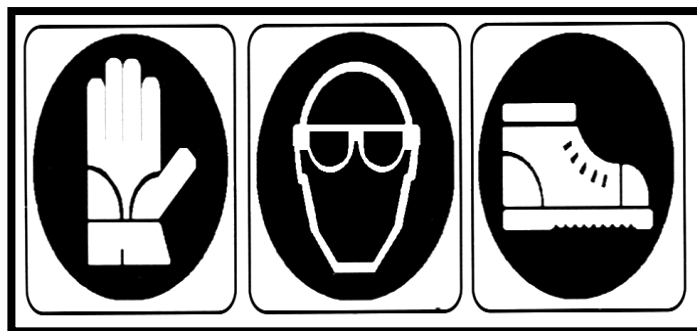

### Power take-off

**NOTE:** Use *ONLY* genuine Weasler parts when replacing any worn or damaged PTO components.

#### *PTO Shield*

##### *Shield Removal*

- To remove the shield, pop out the red snap, then rotate the guard on the bearing to line up the three tabs with the openings and pull it off away from the knuckle joint. Remove the nylon bearing from the shaft by spreading it open.



##### *Shield Assembly*

Be sure to lubricate the groove in the inner yokes where the shield bearing rides. Reinstall shields in the reverse order that they were removed.



##### *Verification on the shield*

The entire shield must turn freely on the shaft. Operating without shields can cause serious injury to the operator.



### Greasing the PTO shaft

Frequent lubrication is required. Grease the driveline parts as required on the chart.

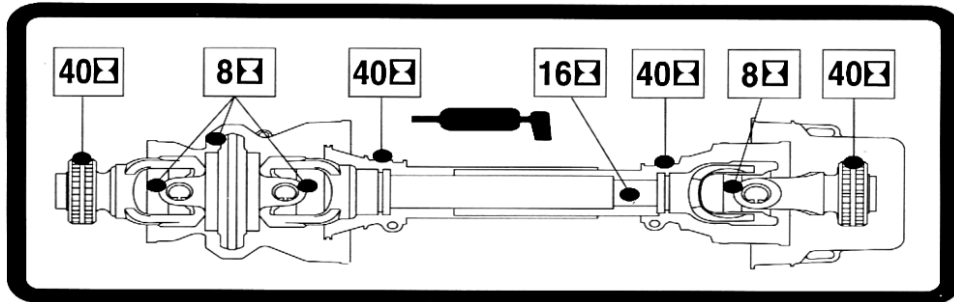

Before a long period of storage grease all the components on the PTO shaft.



**After storage for long periods of time: lubricate and check the function of every driveline component before operating.**

**Failure to grease all the joints VOIDS warranty.**

### Gearbox

There is one grease zerk on the front of the gear box. Apply 3-5 pumps of good quality grease every 8 hours or 150 bales, whichever comes first.

If the gearbox is removed to replace the rotor or perform any other service, add **80 pumps** of grease to the grease zerk upon reinstallation.

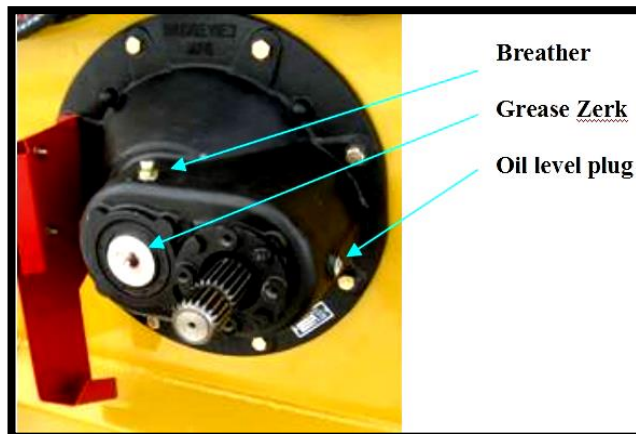

The gear box requires GL5 80W90 gear oil. The oil should be filled to the level plug and checked on a regular basis. The oil should be changed at the following intervals:

- 25 hours after first use
- 50 hours after first use
- Every 300 hours or annually (whichever comes first)





## Hydraulics

### *Hydraulic hose*

Check all hoses and fittings periodically for leaks. Tighten or replace any dripping components or any worn out hoses.

### *Hydraulic cylinder*



***Always cover exposed cylinder shafts with grease to avoid rusting of shafts if the unit is not used for extended periods of time. Rusted cylinder shafts are NOT covered by warranty***

## Wheels and tires

Examine tires for cuts, bruises, cracks, bulges and penetrations. Inspect and lubricated axles every year.

### *Hub Removal*

Procedure for maintenance and replacing hubs.

1. Elevate and support the rear axle.
2. Check for excessive wheel end play by pulling the tire assembly towards you and by pushing the assembly away from you. Slight end play is acceptable.
3. Rotate tire slowly forwards and backwards. The wheel assembly should turn freely and smoothly. If a excessive wheel end play, restriction to rotation, noise, or "bumpy" rotation you have to replace the bearing unit.
4. Remove the wheel.
5. Remove the dust cap carefully prying progressively around the flange of the cap.
6. Remove the cotter pin from the spindle nut.
7. Unscrew the spindle nut and remove the spindle washer.
8. Remove the hub from the spindle, being careful not to allow the outer bearing cone to fall out. The inner bearing cone will be retained by the seal.
9. Clean all the part and make sure the bearing and the spindle will not get contaminated.





### ***Bearing and seal inspection***

If the bearing presents any pitting or corrosion then the bearing must be replaced. The bearing cup inside the hub must be inspected. When replacing bearing, they should be replaced in sets.

If the bearing is good then repack it with grease.

Whenever the hubs are removed, inspect the seal to ensure that it is not nicked or torn and is still capable of properly sealing the bearing cavity. If there is any question of condition, replace the seal.

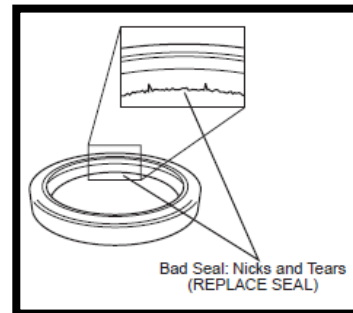

### ***Hub installation***

If the hub has been removed or bearing adjustment is required, the following adjustment procedure must be followed:

1. After placing the hub, bearings, washers, and spindle nut back on the axle spindle in reverse order as detailed in the previous section on hub removal, rotate the hub assembly slowly while tightening the spindle nut to approximately 50 lbs.-ft.
2. Then loosen the spindle nut to remove the torque. Do not rotate the hub.
3. Finely tighten the spindle nut until it snug.
4. Install cotter pin.
5. Install dust cap.
6. Install the wheels and fasten the nuts.

### ***Tires***

Proper tire inflation will prolong the life of the tires.

- Check for proper tire inflation: 25 psi
- Replace any damaged tires: 14Lx16.1 12 ply
- Check and fasten wheel bolts on a regular basis: 125 ft-lb



***NOTE: Warranty does not cover damaged rims and hubs due to loose wheel bolts or flat tires. Tire warranty is covered by the tire manufacturer.***



## Feeding Chain

Lubricate the 2 chains with oil every 50 hours of work and before a long period of storage.

### *Chain Adjustment Procedure*

Check the tension on all 2 chains.

1. Locate the middle of the deck.
2. Apply 30 lbs of pull on the chain and measure 1 inch between the chain and the deck.
3. Loosen the axles on the idler wheel.
4. For tighten the chain just turn the nut clockwise on the idler wheel until you have the right tension.
5. Tighten the nut on the idler wheel.

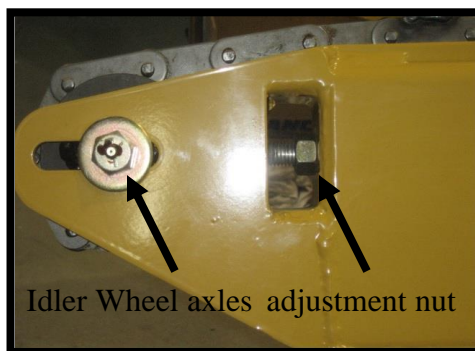

## Twine Removal

- Twine guards are installed to protect the seals and bearings on the wheel hubs, agitator bearings and rotor bearings.
- Inspect all twine guards regularly and remove built up twine.



**Note:** *Shut OFF the tractor and place the tractor in park for twine removal.*

- Twine can be removed with the use of the supplied knife, or any other knife.



***DO NOT burn the twine from the rotor as this has several adverse effects:***



- It may take the temper out of the steel, rendering it weaker.
- Loose straw and hay remaining in the machine may ignite causing a fire in the processor.
- Can cause Excessive build-up of melted plastic.
- May dry out bushings causing them to wear prematurely.



*Bridgeview Manufacturing Inc. VOIDS warranty if twine burning occurs.*

### **Flail and bushing Replacement**

Bridgeview Manufacturing Inc. recommends changing flails **in pairs** (opposite each other). Processing bales with broken flails causes the rotor to be out of balance and excessive vibration may cause machine deterioration.

- Inspect bolt, bushings, and flail for wear. Replace if necessary. Do not re-use lock nuts.
- Tighten bolt so brass bushing will not turn
- ALWAYS use Bridgeview PN 10443  $\frac{3}{4}$  X 4  $\frac{3}{4}$  shoulder bolt. Regular bolts will cause premature bushing wear.



## Transportation

The Bale King 6105 can be safely towed on public roads if the following precautions are taken:

- Tow vehicle must be rated for at least 9000 lb gross weight, and 3000lb tongue weight.
- NEVER exceed 25 mph (40 km/h).
- ALWAYS ensure that the safety chain is properly installed.
- Tow vehicle must have a 7 pin round trailer plug.
- Plug in lights and check for proper functioning (flashing amber lights, solid red lights).
- Ensure that the supplied SMV (Slow Moving Vehicle) sign is clearly visible from the rear.
- Lock side deflector in upright position.
- Ensure that the PTO and hydraulic hoses are properly secured.



## Greasing location

Lubricating should be done on a regular basis.

Item	Location	Timeline
A	Agitator bearing x 2	150 Bales or 8 hours whichever comes first
B	Rotor bearing x 1	
C	Back fork pivot x 2	
D	Cylinder x1	1000 Bales (or 50 hours)
E	Wheel hubs x 4	Seasonally (or 300 hours)
F	Deck pivot x 2	1000 Bales ( or 50 hours)
G	Hoop handle x 1	200 Bales (or 10 hours)

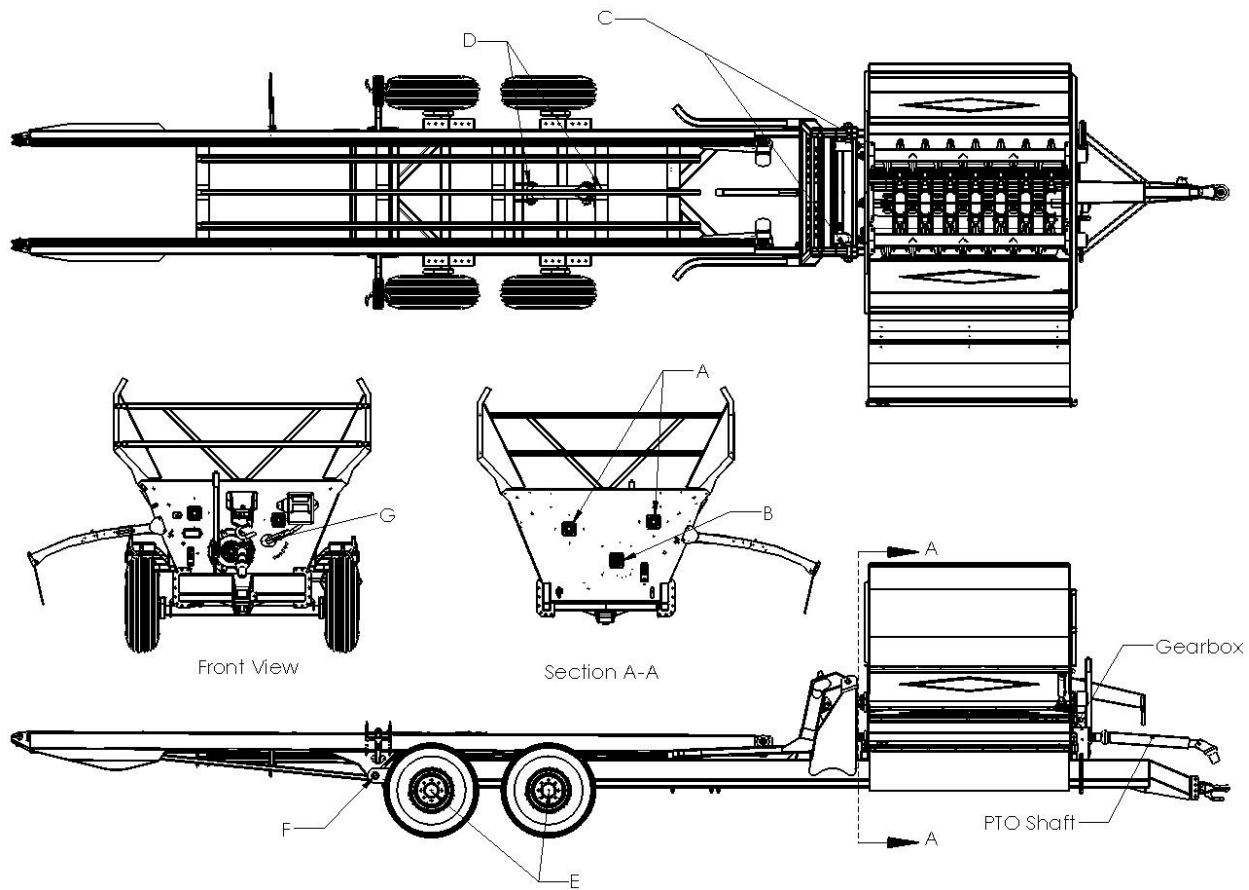



## Troubleshoot guide

Problem	Possible Cause	Remedy
Excessive main shear bolt breakage	Engaging PTO at high engine speed or too quickly	Idle tractor to engage PTO then bring up to full operating speed Feather PTO lever into position
	Excessive twine wrapped on rotor causing flail movement to be restricted	Cut twine off rotor
	Broken flails causing rotor to be out of balance	Replace broken flails (in pairs opposite each other)
	Overloading rotor	Set hoops to less aggressive position Slow rotation of bale Change direction of bale rotation
	Incorrect shear bolt used	Use correct shear bolt
	Operating machine at less than 1000 PTO RPM	Operate machine at rated 1000 PTO RPM
Excessive vibration while processing bales	Excessive twine wrapped on rotor causing flail movement to be restricted	Cut twine off rotor
	Broken flails causing rotor to be out of balance	Replace broken flails (in pairs opposite each other)
	Overloading rotor	Set hoops to less aggressive position Slow rotation of bale Change direction of bale rotation
	Operating machine at less than 1000 PTO RPM	Operate machine at rated 1000 PTO RPM
	Rotor bearing failure	Replace failed parts
Agitators stopping	Excessive loose material in tub causing agitator to jam	Reverse direction of bale rotation Turn bale more slowly
	Tractor relief pressure set too low	Set tractor relief pressure to at least 2500 psi
A single agitator stopping	Mechanical flow divider valve not functioning correctly	Contact your dealer for repairs
	Coupler between motor and agitator broken	Replace failed parts
A single chain stopping	Mechanical flow divider valve not functioning correctly	Contact your dealer for repairs
	Sprocket is broke	Replace failed parts
	The chain might be off the idler wheel	Put the chain back on and tight the chain
Deflector or Tilt doesn't move.	The control box is not plugged in.	Plug in the control box
	The fuse in the control box is failed.	Replace the fuse





## Features and Specifications

### Dimensions:

Overall Weight (empty)	9061 lb
Drawbar Weight ( empty)	3285 lb
Overall Height	105"
Overall Length	462"
Overall Width (Deflector Folded)	102"
Overall Width (Deflector Up)	118"
Overall Width (Deflector Down)	135"
Tread Width (on centers)	79.25"
Tub Opening	80" x 91"
Rotor Extended Tip Diameter	27"
Discharge Opening	12" x 80"
Spring Lock Lever on Grate and Fine Chop Adjusters	
Dual Hydraulic Lift Cylinders (back fork)	3" x 18" x 1.5" Rod
Single Hydraulic Deflector Cylinder	1-1/2" x 6" x 3/4" Rod
Dual Hydraulic Lift Cylinder (Deck)	4" x 14" x 2.0" Rod
Tire Size	14L-16.1SL (12 ply)
Tire Inflation	25 psi
Wheel Nut Torque	125 ft-lb
Minimum Horse Power Requirements	80-150 HP
Required Number of Hydraulic Remotes	3 ( with diverter)
Rated PTO RPM	1000 RPM
Flail Tip Speed at 1000 RPM	7000 FPM
Number of Flails	28
Flail Size	3/4 x 1-1/2 x 7"
Oil Impregnated Bushing in Flails	
Rotor Shaft	1 15/16" Bearing
Agitator Shaft	1 3/4" Bearings
Disc Type Twine Guard	
PTO Shaft	Weasler: Cat. 6 80 deg. C.V.
Shear Bolt	3/8" x 2" Gr. 5
Gearbox Oil	GL5 80W90



## Parts manual

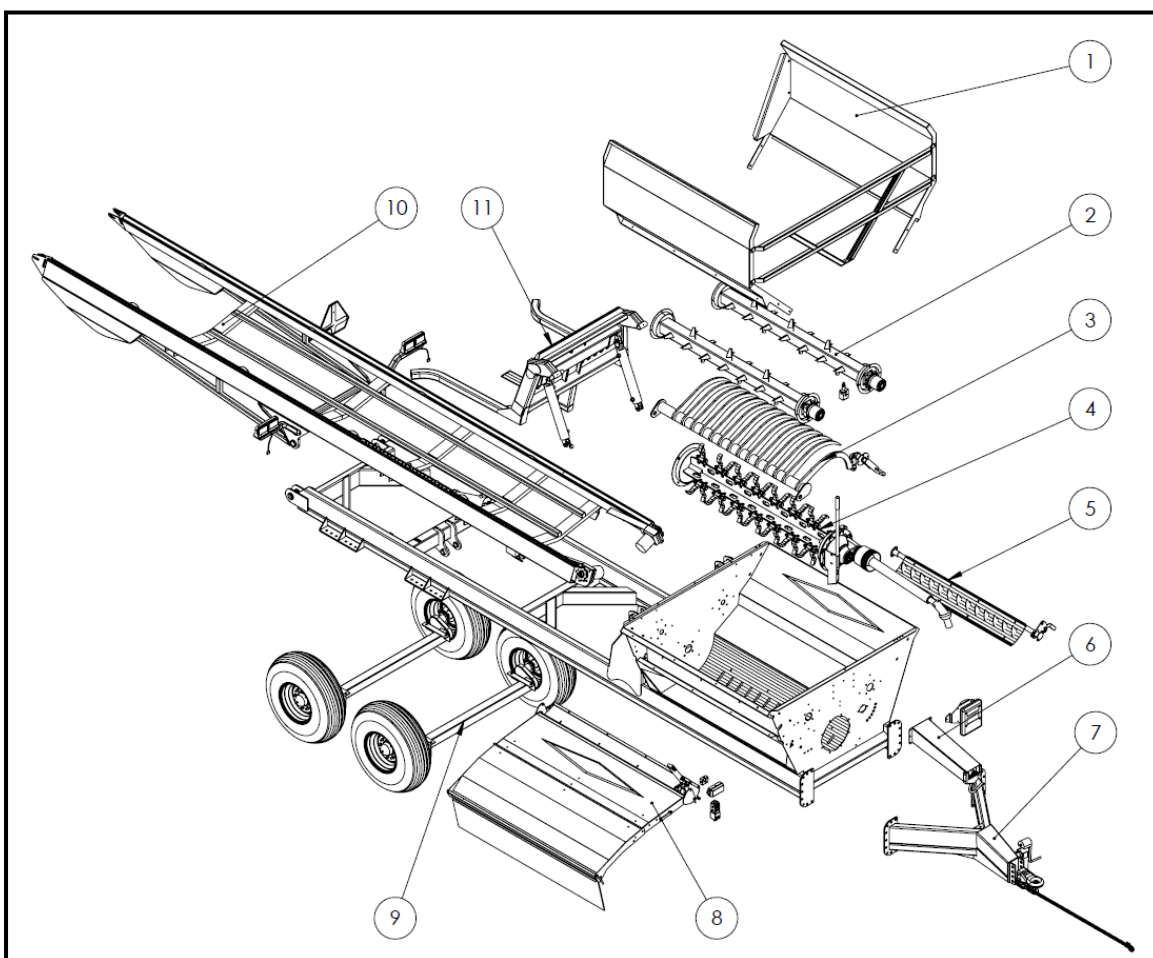

Item #	Description	Item #	Description
1	Upper Tub	7	Hitch
2	Agitator	8	Deflector
3	Hoop and handle	9	Axles
4	Rotor and twine cutter	10	Main deck
5	Fine Chop	11	Loading Fork
6	PTO Holder and Manual		



## Upper Tub

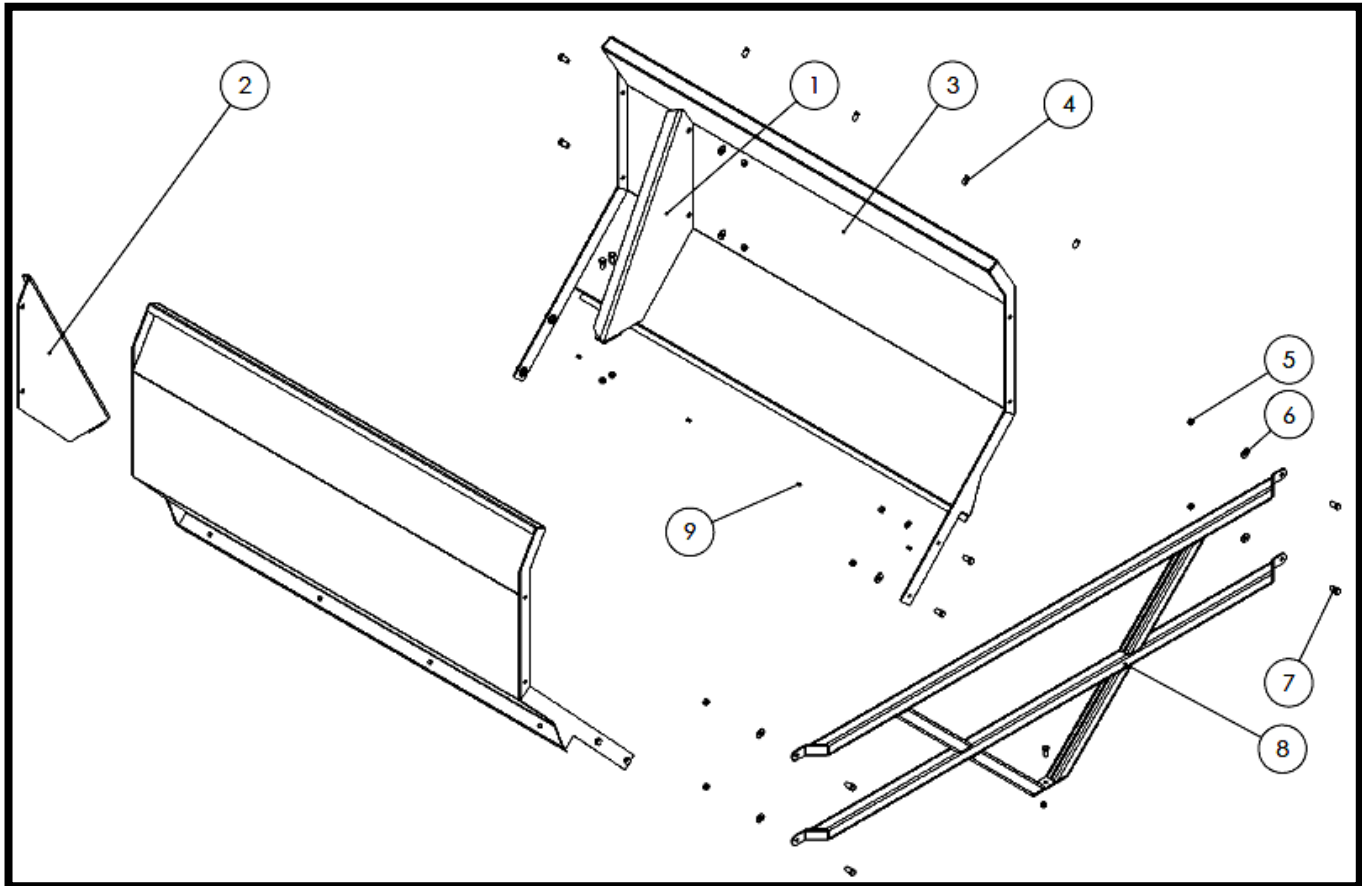

Item #	Description	ID number	QTY.
1	Wing bolt on bracket (left)	22430	1
2	Wing bolt on bracket (right)	22431	1
3	Top Rack	22428	2
4	3/8" x 1" bolt	13806	8
5	1/2" Serrated Flange Nut	10273	21
6	1/2" Flat Washer	11668	21
7	1/2" x 1-1/4" Bolt	10240	21
8	Front Rack	22427	1
9	3/8" Serrated Flange Nut	10271	8



## Agitators

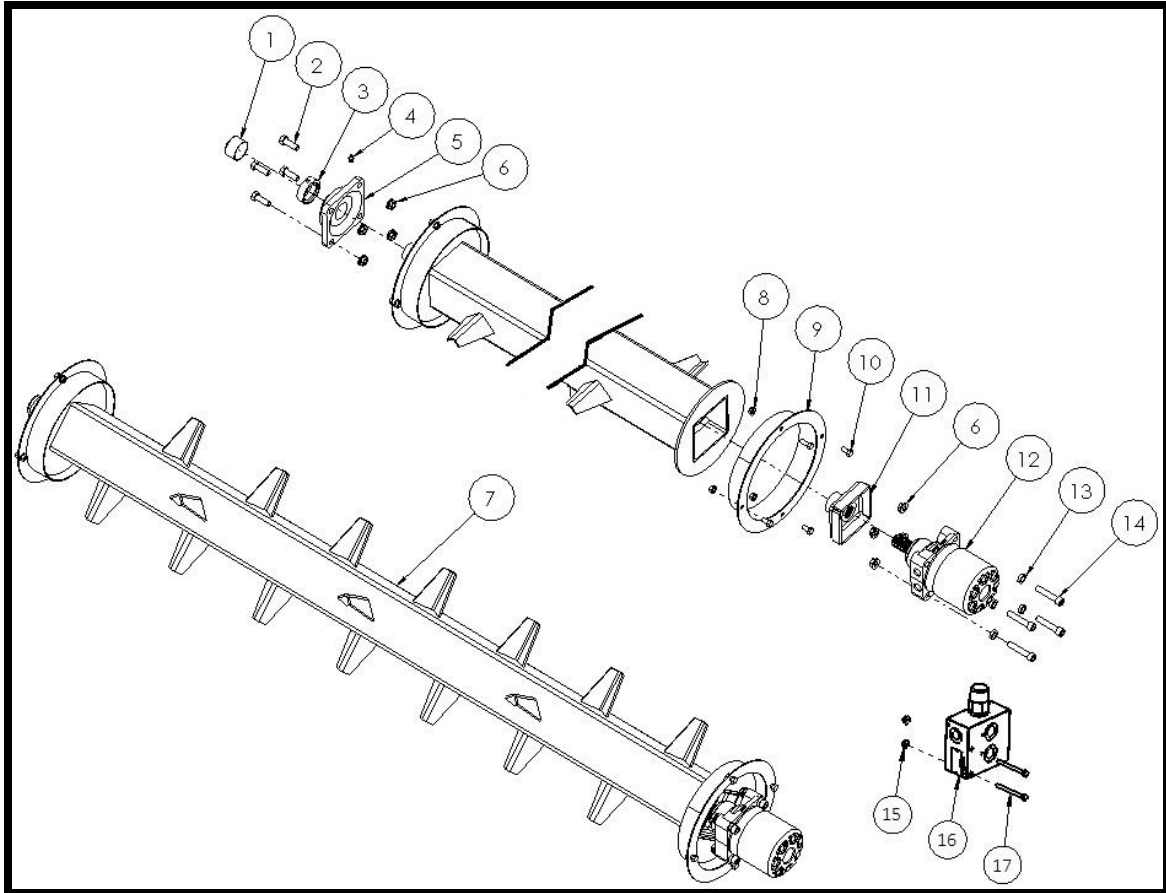



Item #	Description	ID number	QTY.
1	Agitator Shaft Cap	17381	2
2	Bolt, 1/2 x 1-1/2"	10174	8
3	Lock Collar	10040	2
4	Grease Zerk, 1/8" NPT	10270	2
5	Agitator Bearing (Includes 3 & 4)	10038	2
6	Nut, 1/2" Serrated Flange	10273	8
7	Agitator	22418	2
8	Nut, 3/8" Serrated Flange	10271	16
9	Agitator Twine Guard	22419	4
10	Bolt, 3/8 x 3/4"	11816	16
11	Agitator Insert	22084	2
12	Agitator Motor, 8" Long (S/N BK6416 & up)	25872	2
	* Seal Kit	25891	
	Agitator Motor, 6-1/2" Long (S/N BK6415 & below)	21720	
	* Seal Kit	22820	
13	Lock Washer, 1/2"	14447	8
14	Socket Head Bolt, 1/2 x 3" (S/N BK6416 & up)	25952	8
	Socket Head Bolt, 1/2 x 2-1/2" (S/N BK6415 & below)	16863	
15	Nut, 1/4" Serrated Flange	11812	2
16	Flow Divider Valve (S/N BK6416 & up)	25778	1
	(S/N BK6415 & down)	23368	
17	Bolt, 1/4 x 5" (S/N BK6416 & up)	25951	2
	Bolt, 1/4 x 2-3/4" (S/N BK6415 & down)	11811	

**NOTE:** Check the serial number (S/N) of your machine before ordering.



## Hoop Grate and Handle

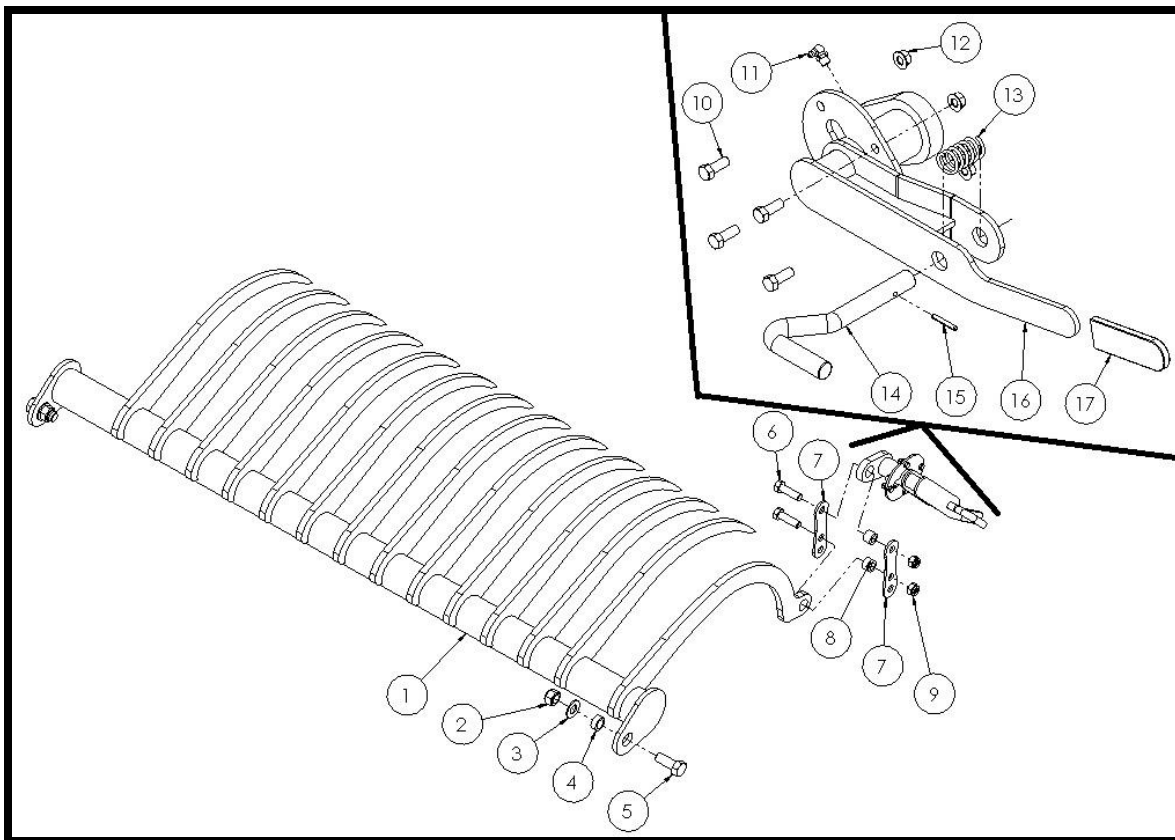

Item #	Description	ID number	QTY.
1	Hoop Assembly	22414	1
2	Nut, 1" Stover Lock	21746	2
3	Flat Washer, 1"	14472	2
4	Hoop Pivot Bushing	22417	2
5	Bolt, 1 x 2-1/2"	21820	2
6	Bolt, 3/4 x 2-1/2"	14470	2
7	Hoop Shackle	22416	2
8	Hoop Shackle Bushing	22415	2
9	Nut, 3/4" Nylon Lock	10007	2
10	Bolt, 3/8 x 1"	13806	4
11	Grease Zerk, 1/4"-28 x 90deg	16389	1
12	Nut, 3/8" Serrated Flange	10271	4
13	Hoop Handle Spring	19471	1
14	S-Handle	22187	1
15	Roll Pin, 3/16 x 1-1/4"	10302	1
16	Hoop Handle	22023	1
17	Rubber Cover	10297	1



## Rotor and twine cutter

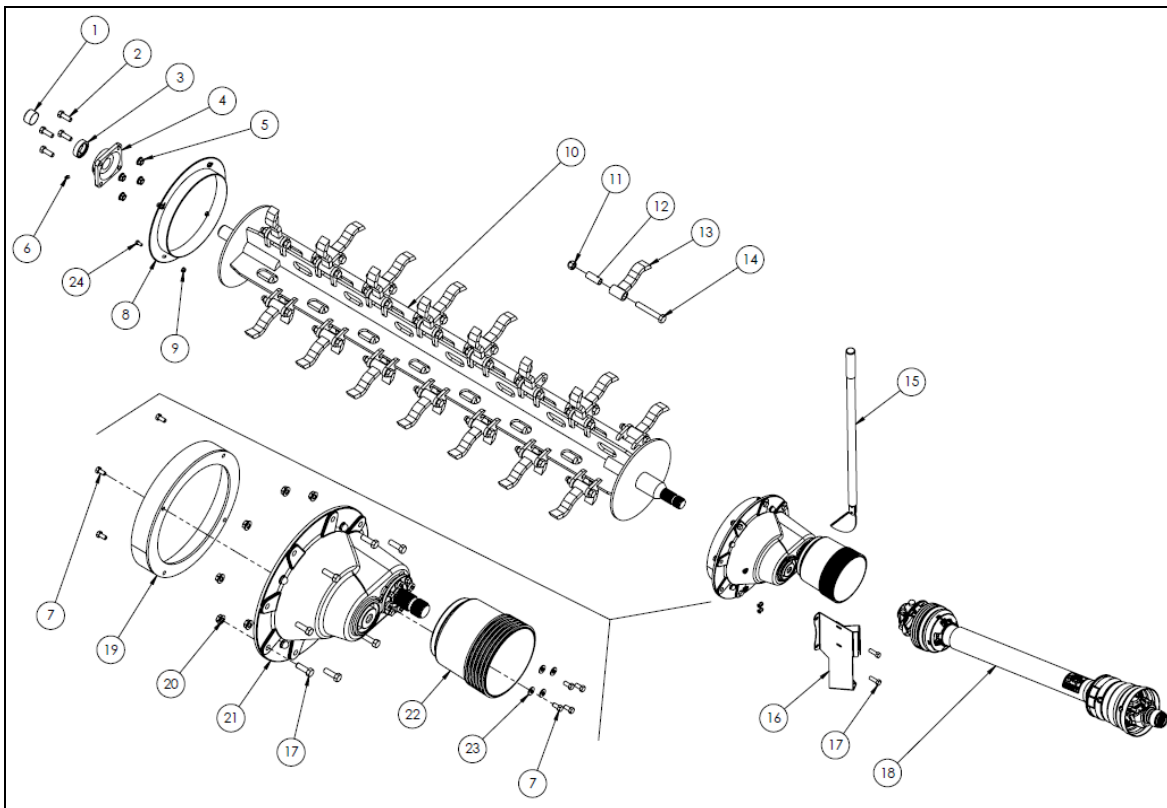

#	DESCRIPTION	PART #	QTY
1	Rotor Shaft Cap	17380	1
2	Bolt, 5/8" x 1-3/4" NF Gr. 8	10274	4
3	Lock Collar	10268	1
4	Rotor Bearing * Includes # 3 & 6 *	10221	1
5	Nut, 5/8" NF Serrated Flange Gr. 8	15398	4
6	Grease Zerk, 1/8" NPT Straight	10270	1
7	Bolt, 3/8" x 3/4"	11816	8
8	Rotor Twine Guard, Rear	22413	1
9	Nut, 3/8" Serrated Flange	10271	4
10	X-Rotor Weldment	22449	1
11	Nut, 3/4" Stover Lock	11823	28
12	Brass Flail Bushing	10005	28
13	Rotor Flail	22412	28
14	Bolt, 3/4" x 4-3/4"	10443	28
15	Twine Cutter Handle * See Breakdown *	-	1
16	Twine Cutter Holder * See Breakdown *	-	1
17	Bolt, 1/2" x 1-1/2"	10174	8
18	PTO Shaft * See Breakdown *	-	1
19	Gearbox Twine Guard	23002	1
20	Nut, 1/2" Serrated Flange	10273	8
21	Gearbox Assembly * See Breakdown *	-	1
22	PTO Safety Shield	10421	1
23	Flat Washer, 3/8"	11667	4
24	Bolt, 3/8 x 1"	13806	4





### 10" 28 Flail X Rotor

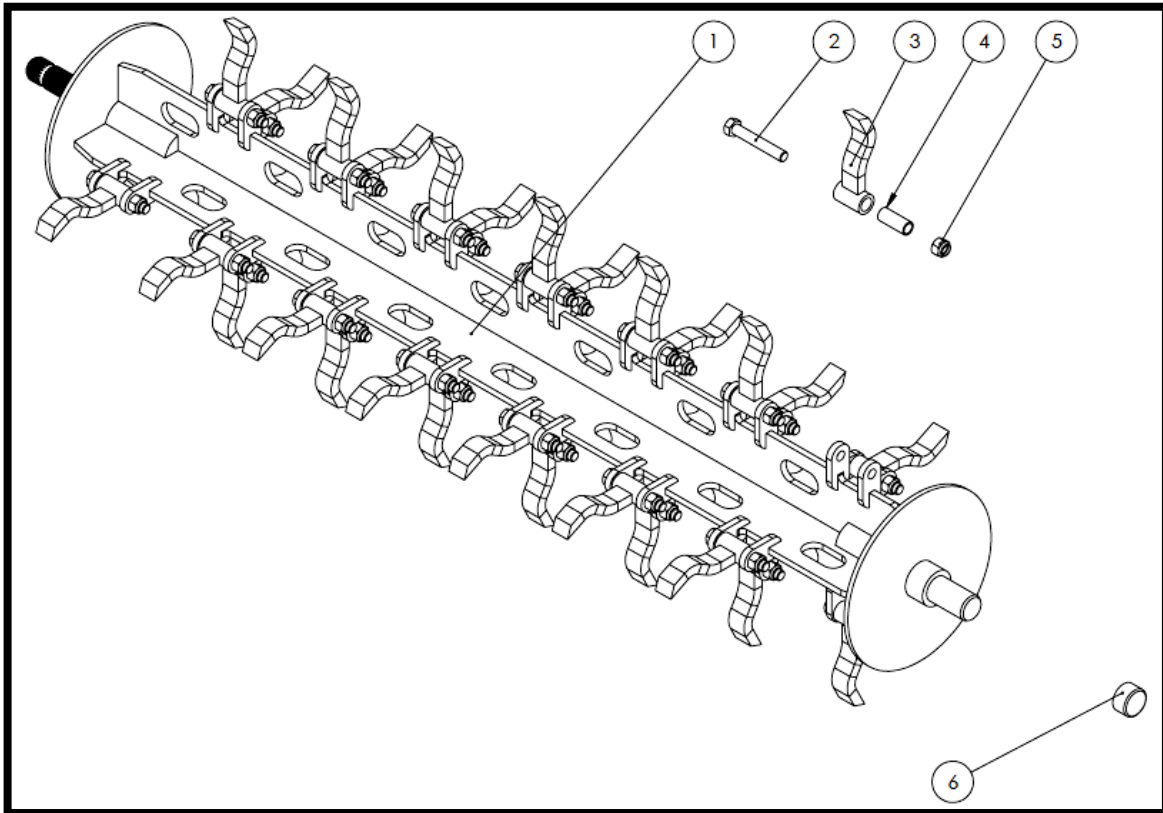

Item #	Description	ID number	QTY.
1	10" 28 Flail X Rotor	22449	1
2	3/4" x 4.75" Bolt	10443	28
3	Flail	22412	28
4	Flail Bushing	10005	28
5	3/4" Stover Lock Nut	11823	28
6	Rotor Shaft Cap	17380	1



### Gearbox Assembly

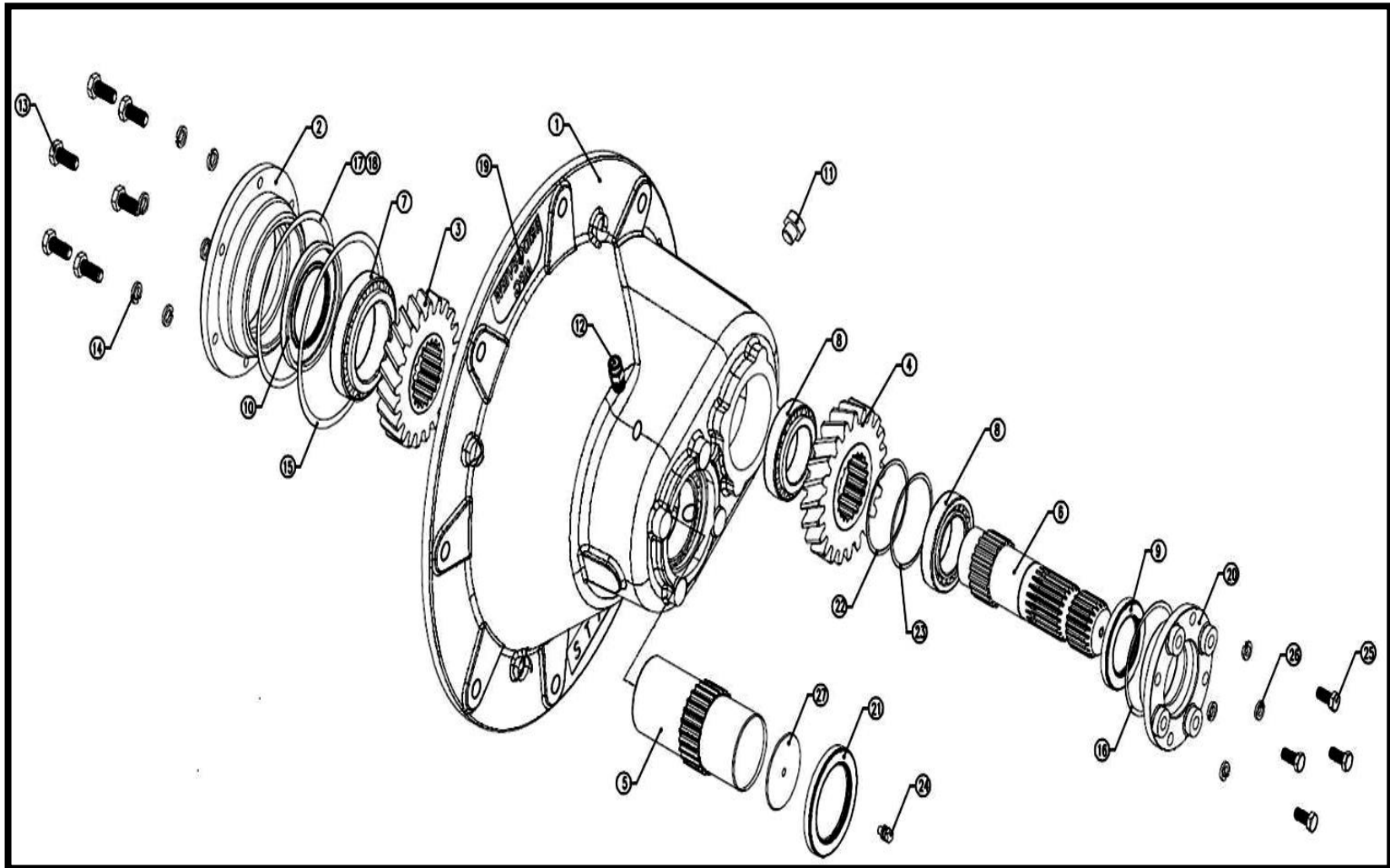



<b>ITEM #</b>	<b>DESCRIPTION</b>	<b>ID NO</b>	<b>QTY.</b>
1	Housing	22158	1
2	End Cap	22158	1
3	Output Gear	22158	1
4	Input Gear	22158	1
5	Output Shaft	22158	1
6	Input Shaft	22158	1
7	Bearing(32012)	10496	2
8	Bearing(32009)	10497	2
9	Seal 45x60x8	24013	1
10	Seal 60x100x10	10498	1
11	3/8 NPT Pipe Plug	24014	2
12	3/8 NPT Relief Plug	24015	1
13	M8x25 Bolt Gr8.8	24026	6
14	M8 Lock Washer	24016	6
15	O-Ring	24017	1
16	O-Ring	24018	1
17	Shim 125x164x0.1	24022	2
18	Shim 125x164x0.3	24023	2
19	Name Plate(Bridgeview)	---	---
20	End Cap	22158	1
21	Seal 60x85x10	10500	1
22	Shim 68x74.5x0.1	24024	2
23	Shim 68x74.5x0.3	24025	2
24	1/4-28 UNF Grease Nipple	12080	1
25	M10x25 Bolt Gr8.8	15087	4
26	M10 Lock Washer	24021	4
27	Press Cup	24446	1



## Twine Cutter

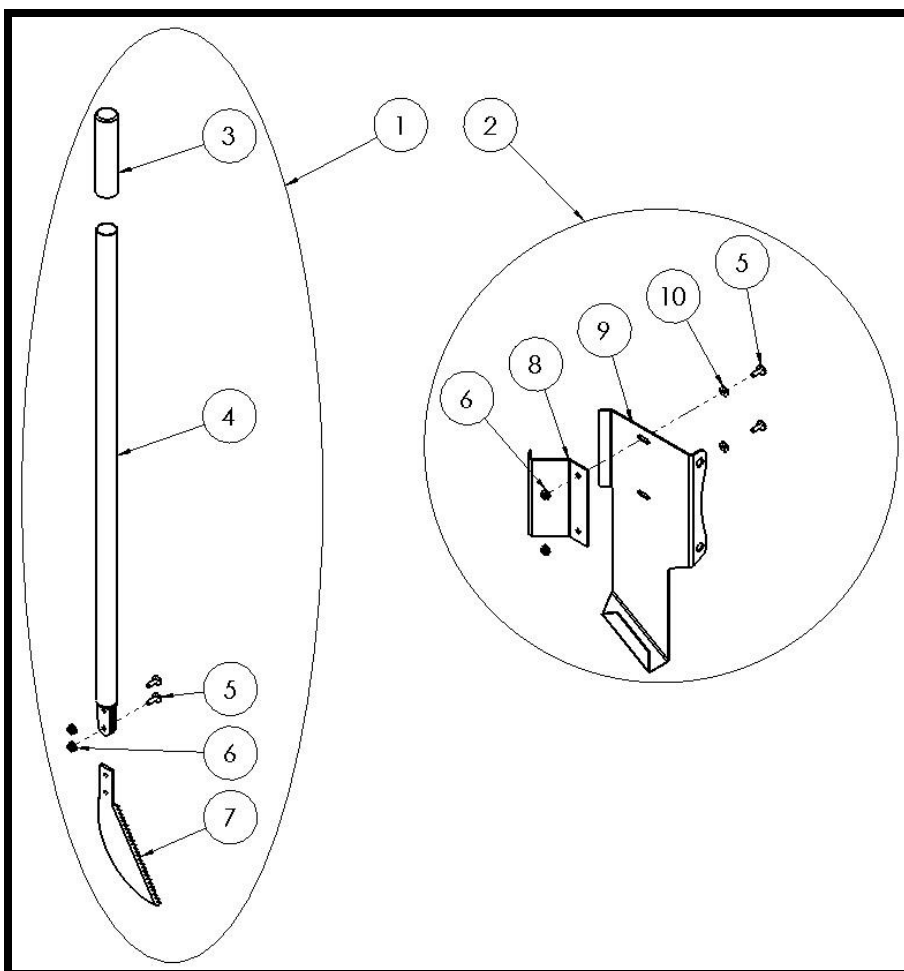

Item #	Description	ID number	QTY.
1	Twine Cutter Handle Kit	-	1
2	Twine Cutter Holder Kit	21549	1
3	Rubber Handle	17587	1
4	Twine Cutter Handle	20862	1
5	1/4" x 3/4" Bolt	17638	4
6	1/4" Serrated Flange Nut	11812	4
7	Twine Cutter Blade	17438	1
8	Twine Cutter Holder Inside	17690	1
9	Twine Cutter Holder Outside	17691	1
10	1/4" Flat Washer	11666	2



## Complete PTO Assembly, Weasler Cat. 6

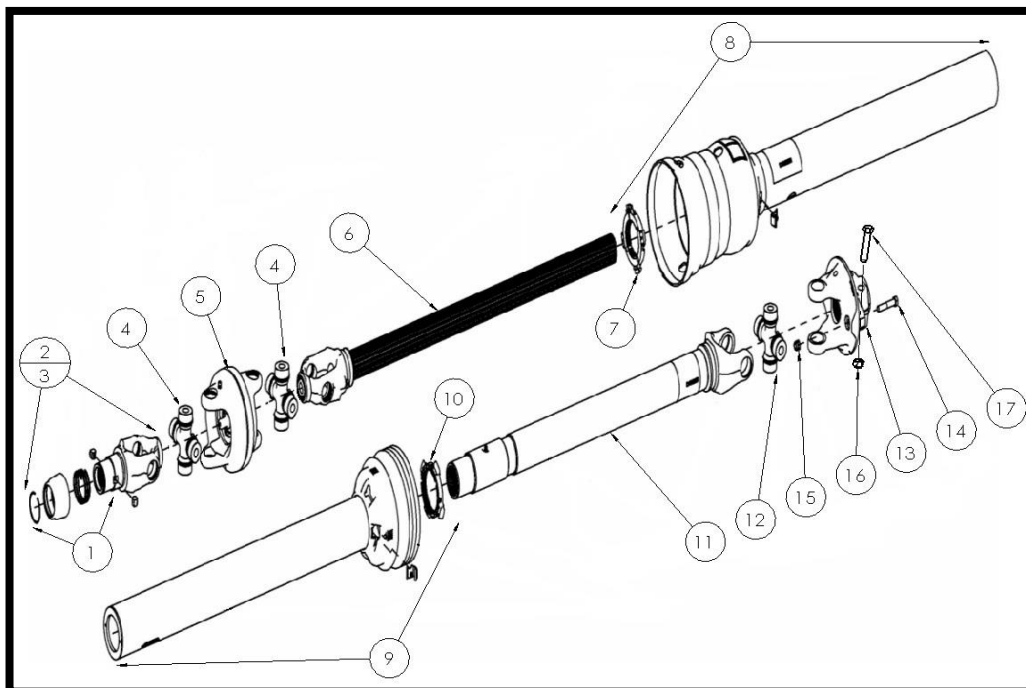

Item #	Description	ID #	QTY.
	Complete PTO Shaft Assembly	20546	1
1a	Safety Slide Lock Repair Kit (1-3/8"-21 Spline)	17567	(1)
1b	Safety Slide Lock Repair Kit (1-3/4"-20 Spline)	24981	(1)
2	WWCV Auto-Lok Yoke Assembly (1-3/8"-21 Spline)	20549	(1)
3	WWCV Auto-Lok Yoke Assembly (1-3/4"-20 Spline)	20556	(1)
4	CV Cross and Bearing Kit (Equal Length)	20550	2
5	CV Center Housing	20551	1
6	Yoke & Shaft Assembly Tractor Side	20552	1
7	Guard Repair Kit Tractor Side	20553	1
8	Guard Assembly Tractor Side	17583	1
9	Guard Assembly Implement Side	17585	1
10	Guard Repair Kit Implement Side	17572	1
11	Yoke & Tube Assembly Implement Side	17584	1
12	U-joint Cross & Bearing Kit	17573	1
13	Shear Assembly * Does not come with bolts 14 or 16 *	17581	1
14	Shear Bolt, 3/8" x 2"	11817	1
15	Nut, 3/8" Stover Lock	17586	1
16	Nut, 5/8" Stover Lock	24982	2
17	Bolt, 5/8" x 3-1/2"	24983	2

**NOTE:** Ensure that the PTO shaft on the machine is correct to the drawings below. Equal length CV cross (4.19") with bearing cup diameter 1.38". If the damaged PTO has different dimensions, consult the Bridgeview Manufacturing website.

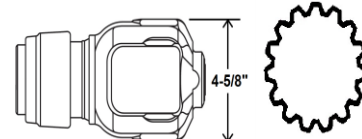



## PTO Holder and Manual

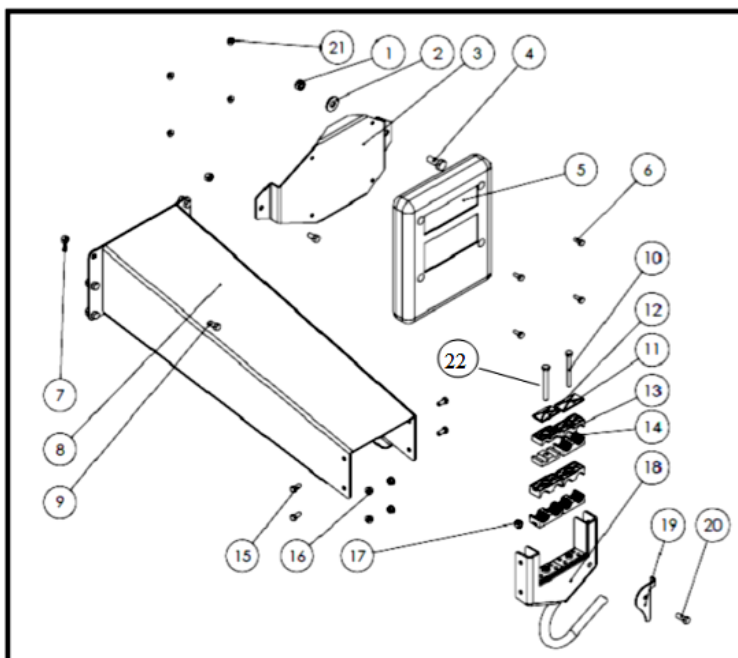

Item #	Description	ID number	QTY.
1	1/2" Serrated Flange Nut	10273	1
2	1/2" Flat Washer	11668	1
3	Manual Cover Mount	22439	1
4	1/2" x 1-1/4" Bolt	10240	1
5	Operator Manual Cover	22409	1
6	1/4" x 3/4" Bolt	11809	4
7	3/8" Serrated Flange Nut	10271	8
8	PTO holder long channel	22836	1
9	3/8" x 1.0" Bolt	13806	7
10	5/16" x 3" Bolt	22844	1
11	Hose Clamp Top 1/2" Hose	21725	1
12	Hose Clamp Top 1/4" Hose	22182	1
13	Hydraulic Hose Clamp 1/2"	21561	4
	Hydraulic Hose Clamp 3/8"	22180	2
14	Hydraulic Hose Clamp 1/4"	22181	2
15	5/16" x 3/4" Bolt	20903	4
16	5/16" Serrated Flange Nut.	11814	4
17	3/8" Nylon Lock Nut	10806	1
18	Front Plate	22839	1
19	PTO Transport Lock	22450	1
20	3/8" x 1" Bolt	13806	1
21	1/4" Serrated Flange Nut	11812	4
22	5/16"x3 1/2" Bolt	13765	1



# Hitch

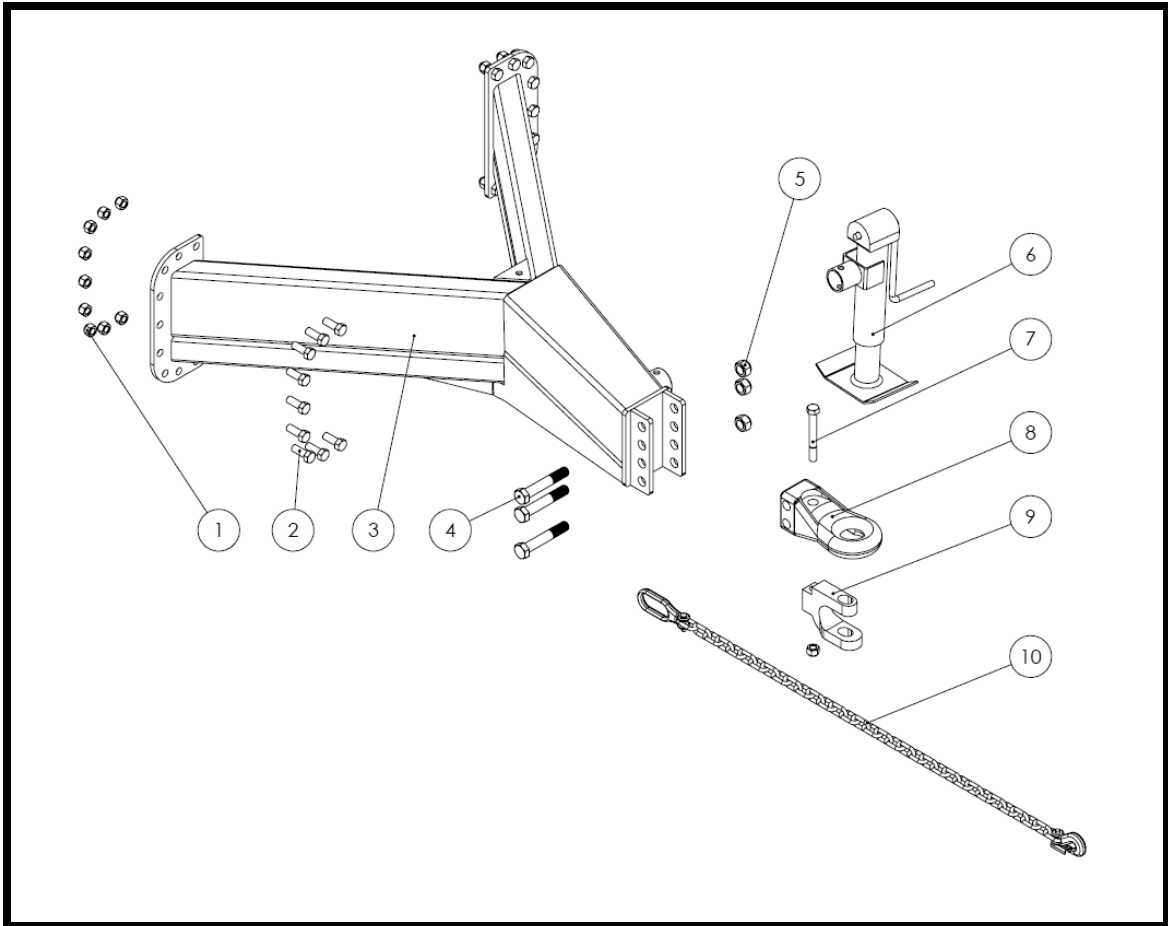

Item #	Description	ID number	QTY.
1	3/4" Stover Lock Nut	11823	19
2	3/4" x 2" Bolt	13800	18
3	Hitch	24478	1
4	1" x 6" Bolt	21728	3
5	1" Stover Lock Nut	21746	3
6	7000 LBS Jack	23677	1
7	3/4" x 6" Bolt GR.8	23170	1
8	Casting Hitch (7500 LBS)	23404	1
9	Hitch Clevis	22441	1
10	21000 LBS Safety Chain	23559	1





# Deflector

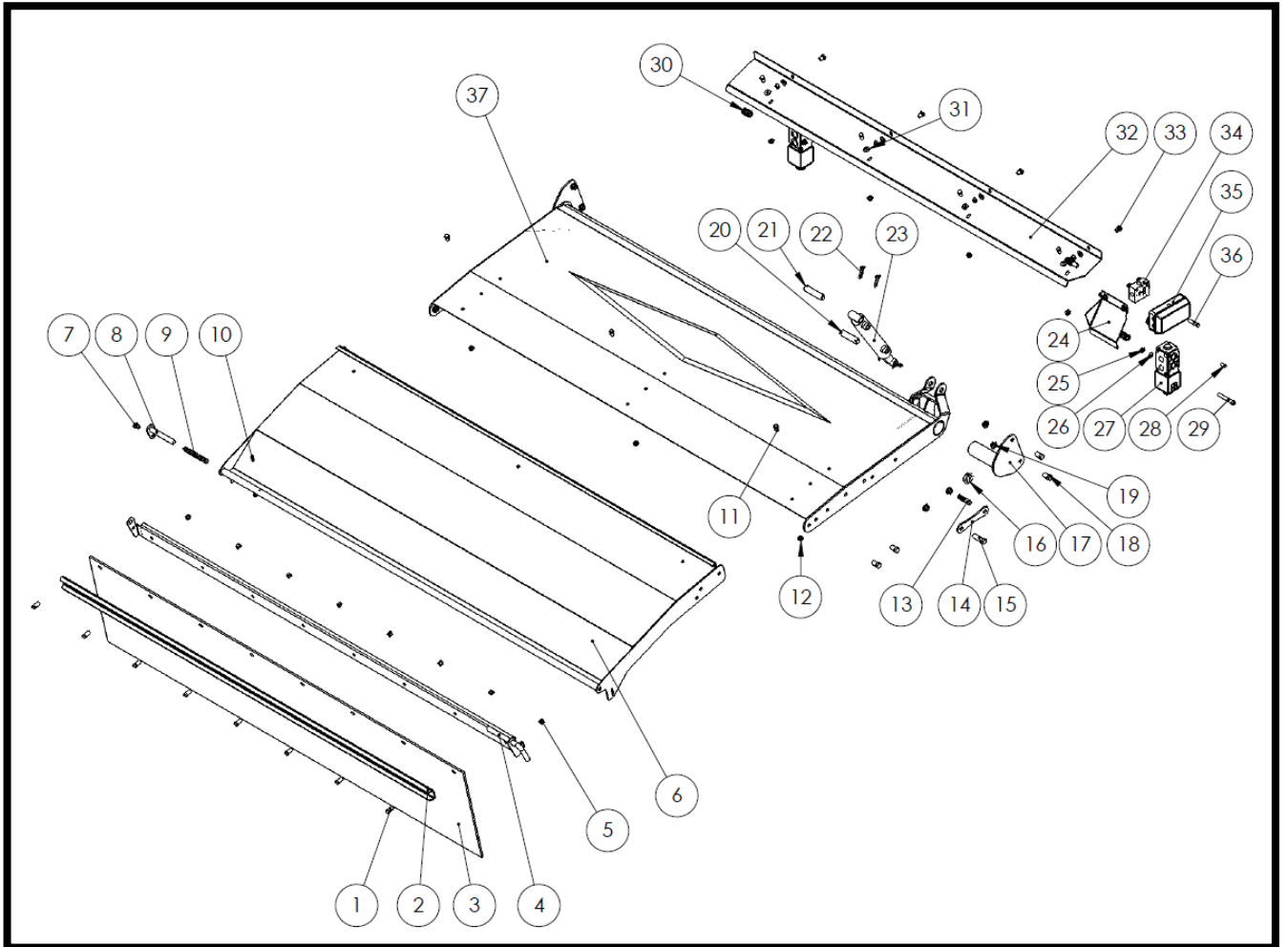



Item #	Description	ID number	QTY.
1	3/8" x 1.0" Bolt	13806	8
2	Rubber Support Channel	22423	1
3	Deflector Rubber	10477	1
4	Rubber Pivot	24463	1
5	3/8" Nylon Lock Nut	10806	8
6	Outer Deflector	24448	1
7	3/8" x 3/4" Carriage Bolt	14072	1
8	Rubber Pivot Pin	24464	1
9	Compression Spring	24461	1
10	3/16" x 1-1/4" Roll Pin	10302	1
11	3/8" x 3/4" Bolt	11816	7
12	3/8" Serrated Flange Nut	10271	9
13	1/2" x 2-1/2" Threaded Pin	13231	2
14	Deflector Lock Bar	22422	1
15	1/2" x 2 Bolt	10322	1
16	3/16" Lynch Pin	13233	1
17	Deflector Pivot	22426	2
18	1/2" x 1" Bolt	10824	8
19	1/2" Serrated Flange Nut	10273	14
20	Cylinder Pin: 3/4" x 3-1/2" (2-3/4" Usable)	22008	1
21	Cylinder Pin: 3/4" x 3-3/4" (3" Usable)	22007	1
22	Cotter Pin (3/16" x 1-1/4")	11669	4
23	Hydraulic Cylinder (1.5 x 6 x 1)	21711	1
24	Deflector Fill Plate #	22945	1
25	5/16" Serrated Flange Nut	11814	8
26	5/16" Flat Washer	12496	4
27	Electrical Diverter Valve	11743	2
28	5/16" x 1.0" Bolt	20906	2
29	5/16" x 3.0" Socket Head Bolt	11783	4
30	Push-in Grommets 7/16" ID	21428	3
31	3/8" Flat Washer	11667	10
32	Hose Cover Panel	22436	1
33	3/8" x 3/4" Carriage Bolt	14072	6
34	Pilot Operated Check Valve	19114	1
35	Junction Box	13668	1
36	5/16" x 1-3/4" Bolt	21726	2
37	Inner Deflector	22425	1

# NOTE: For machines with a rigid rubber deflector, order kit **#25078** to upgrade to a flip-style deflector.

@ NOTE: For machines without a front cover, order kit **#23220**



## Axles

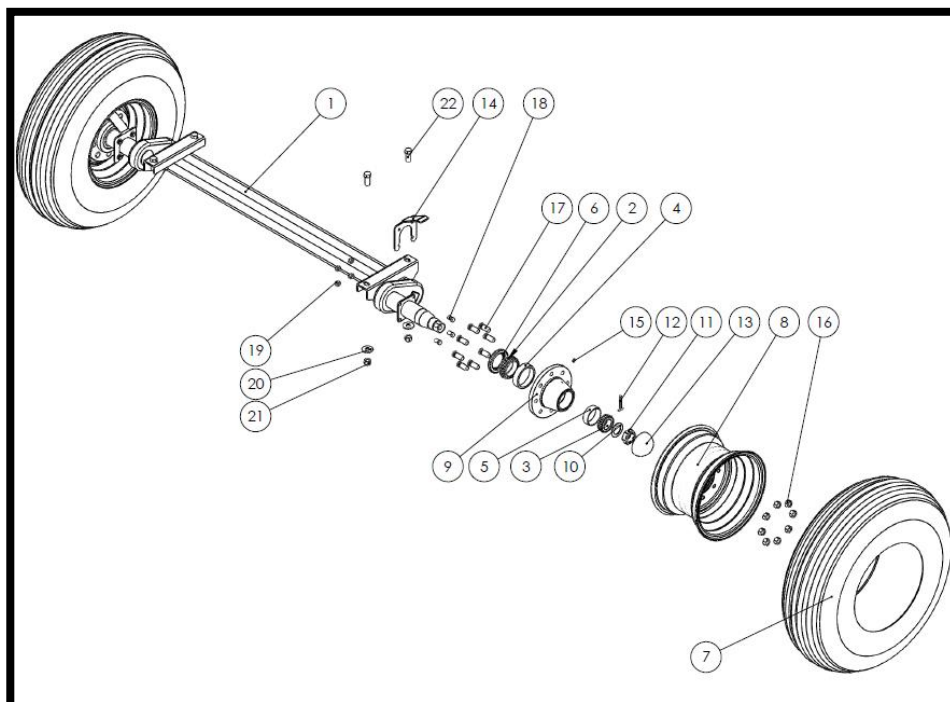

Item #	Description	ID number	QTY.
1	Torflex axles	22850	1
2	Inner Bearing	23567	2
3	Outer Bearing	23568	2
4	Inner Cup	23571	2
5	Outer Cup	23570	2
6	Seal	23569	2
7	Tire 14L-16.1SL (12 Ply)	22851	2
8	Rims W11C x 16.1 x 8	23742	2
9	Hubs 8 on 8	23572	2
10	Washer For Spindle	23564	2
11	Castle Nut	23566	2
12	Cotter Pin	23565	2
13	Dust Cap	23563	2
14	Twine Guard	23744	2
15	Grease Zerk (Hubs)	10270	2
16	Wheel Nut	23183	16
17	Wheel Stud	23573	16
18	1/2" x 1-1/4" Bolt	10240	8
19	1/2" Serrated Flange Nut	10273	8
20	3/4" Flat Washer	13717	4
21	3/4" Stover Lock Nut	11823	4
22	3/2" x 2.0" Bolt	13800	4



# Main deck

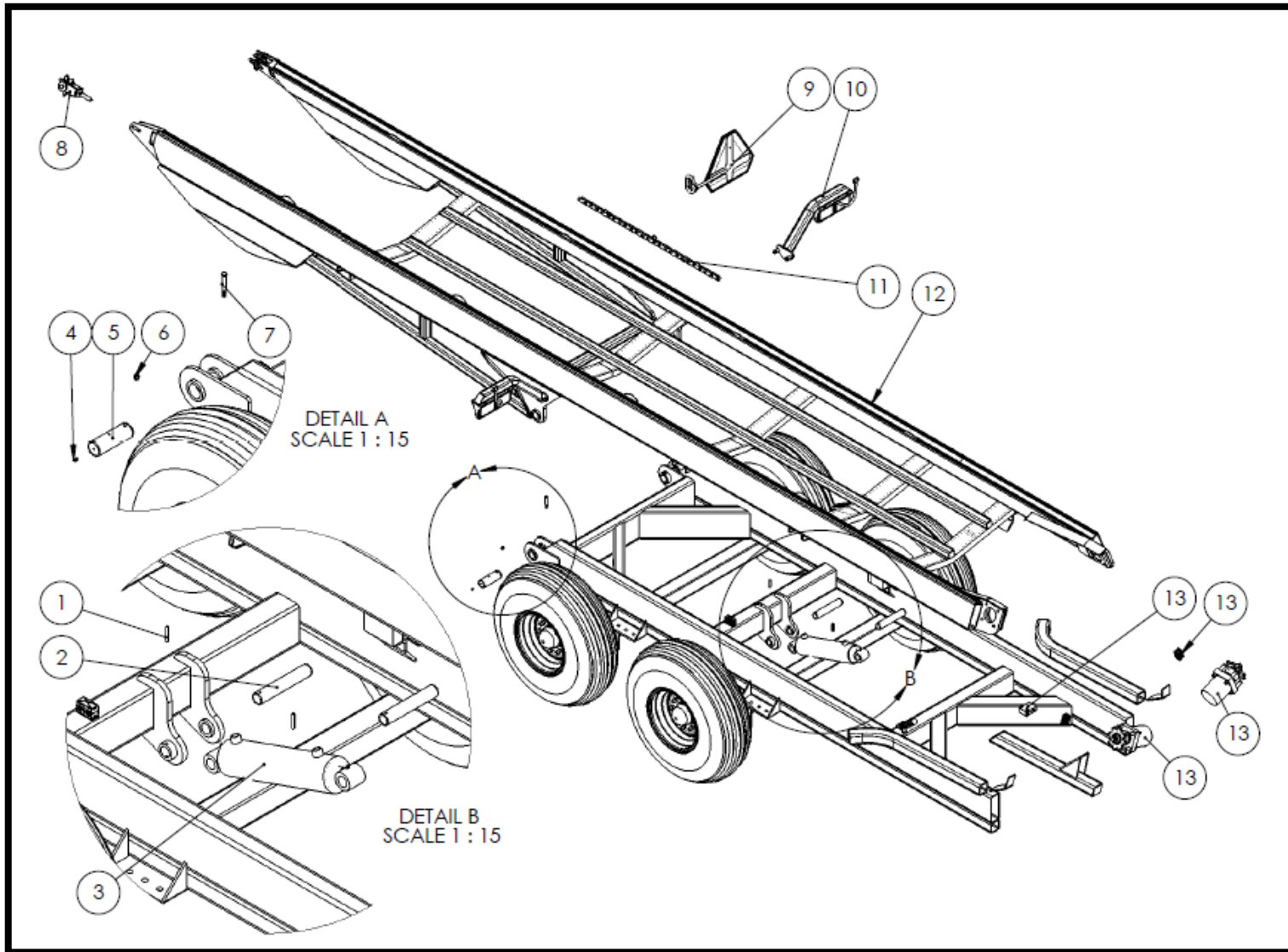



Item #	Description	ID number	QTY
1	1/4" x 2-1/4" Roll Pin	23544	2
2	Cylinder Pin	24132	2
3	Hydraulic Cylinder (4 x 12 x 2)	23094	1
4	Grease Zerk	16364	4
5	3/8" Nylon Lock Nut	10806	2
6	Pivot Pins	23596	2
7	3/8" x 3-1/4" Bolt	23325	2
8	Idler Sprocket Assembly	See Breakdown	2
9	Slow moving sign	See Breakdown	1
10	Light Assembly	See Breakdown	2
11	2082 Chain With Tab	24748	2
	2082 Connector	23093	2
12	Main Deck	247272	1
13	Chain Motor Assembly	See Breakdown	--

### Slow Moving Vehicle Sign

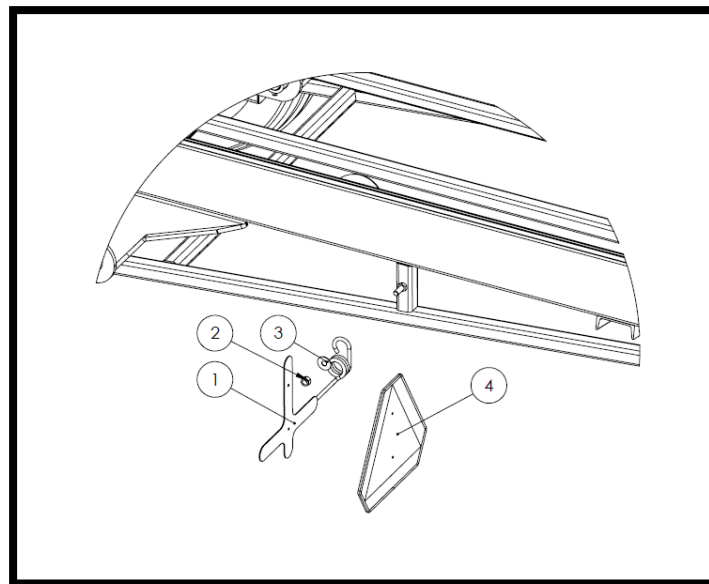

Item #	Description	ID number	QTY
1	SMV Sign Bracket	24656	1
2	5/8" Nylon Lock Nut	10364	1
3	5/8" Flat Washer	17972	1
4	Plastic SMV Sign Kit	22411	1



## Idler Wheel Assembly

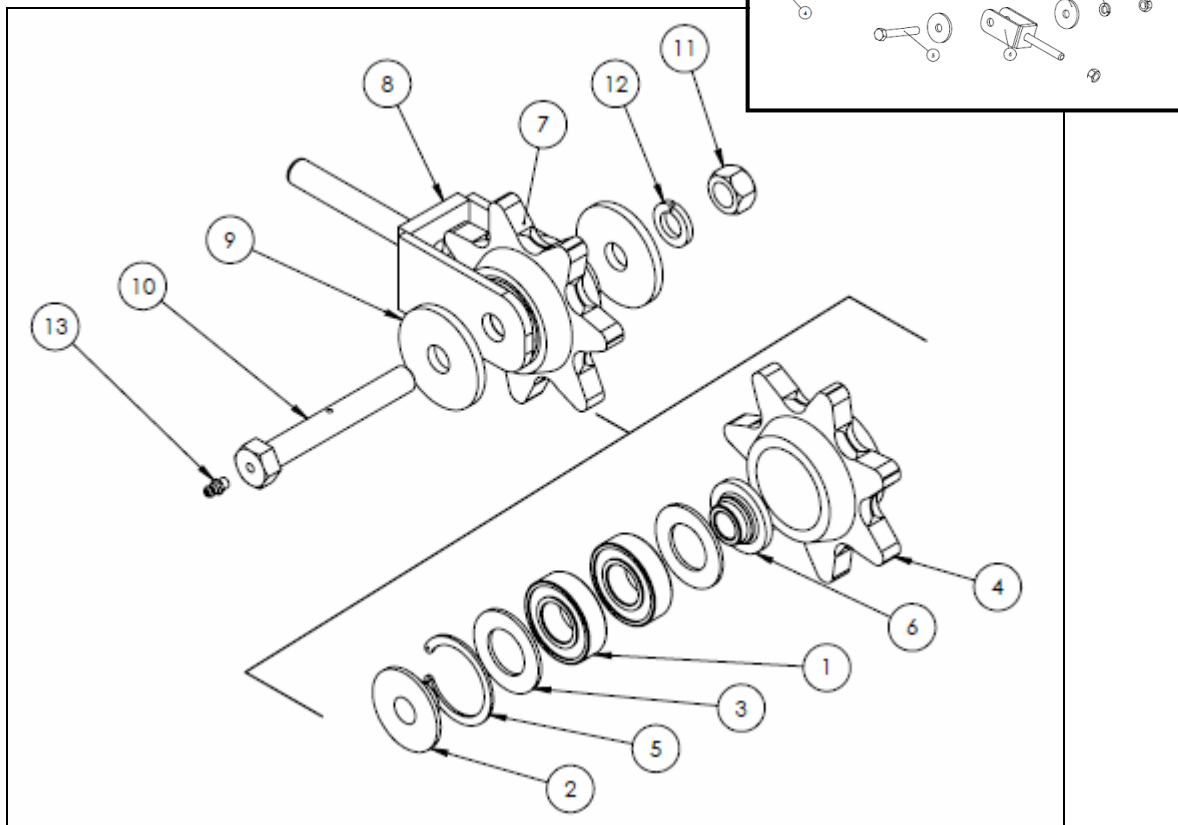

Upper picture shows the single bearing sprocket found on earlier models of the 6105. These models require 10 and 13 to use the double bearing sprocket.

Item #	Description	ID number	QTY.
1	Idler Sprocket Bearing	23757	(2)
2	Bushing, Snap Ring Side	27681	(1)
3	Spacer	27681	(2)
4	Idler Sprocket (Sprocket only)	27497	(1)
5	Snap Ring	23755	(1)
6	Bushing, Non-Snap Ring Side	27682	(1)
7	Complete Idler Sprocket Assembly	27683	1
8	Chain Tensioner Bracket	28389	1
9	5/8" Heavy Flat Washer	17972	2
10	Grease-able 5/8" x 4-1/2" Bolt	23597	1
11	5/8" Nut	10176	1
12	5/8" Lock Washer	13792	1
13	Grease Zerk	16364	1



## Light assembly

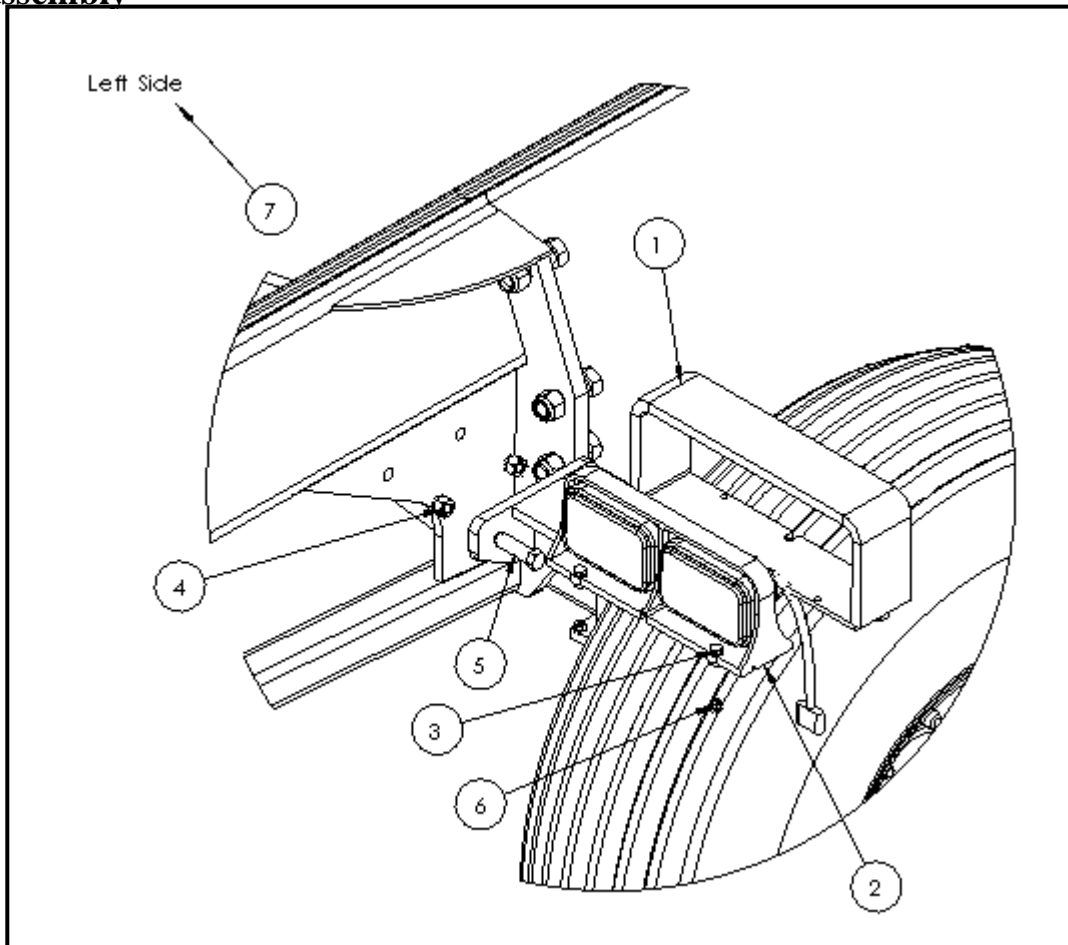

Note: There are previous designs of light brackets. This light bracket can replace any previous version without tire contact.

Item #	Description	ID number	QTY.
1	Light Bracket	28689	2
2	Right Light	22969	1
3	1/4" x 1" Bolt	11810	8
4	1/2" Stover Lock Nut	20154	4
5	1/2" x 2" Bolt	10322	4
6	1/4" Nylon Lock Nut	11664	8
7	Left Light	22968	1





## Chain Motor Assembly

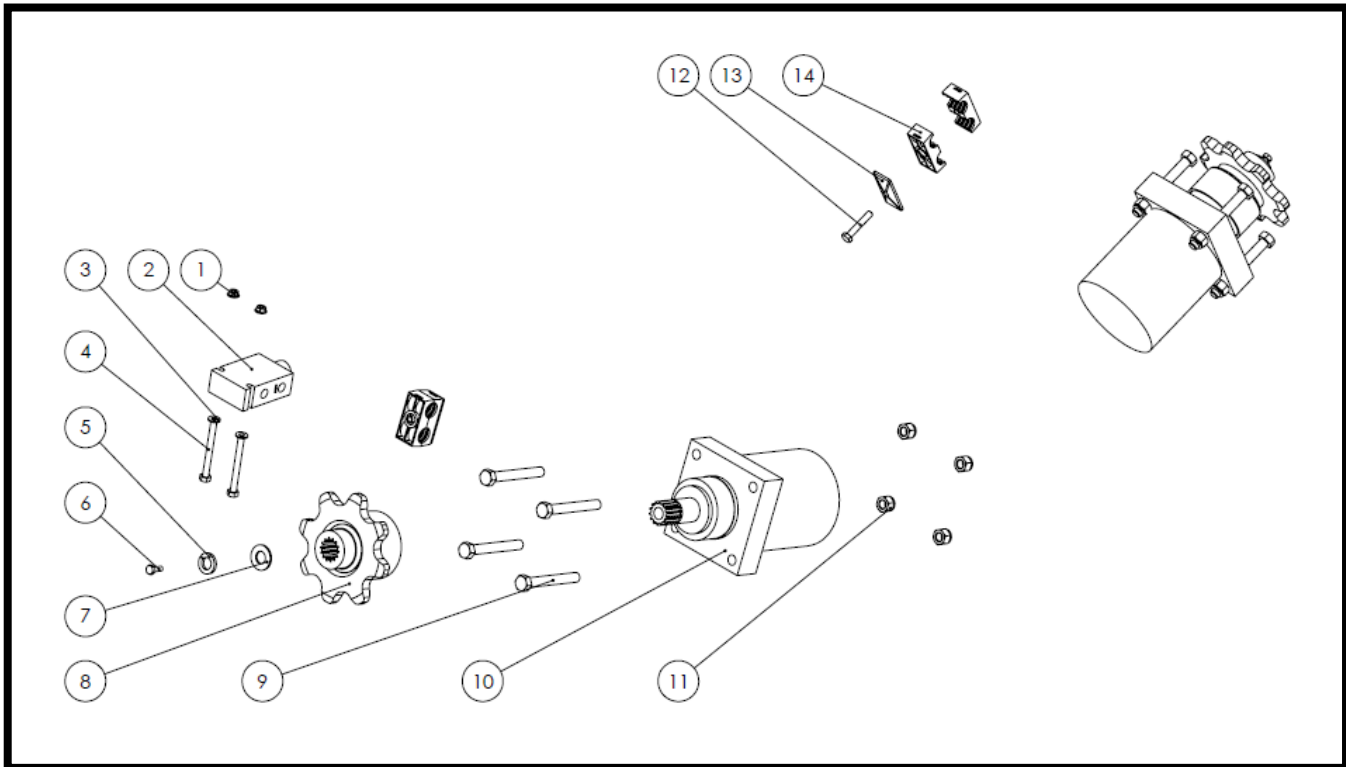

Item #	Description	ID number	QTY.
1	1/4" Serrated Flange Nut	11812	2
2	Flow Divider (2082 Chain)	11742	1
3	1/4" Flat Washer	11666	2
4	1/4" x 2-3/4" Bolt	11811	2
5	5/8" Lock Washer	13792	2
6	5/8" x 1-1/4" Bolt NF Grade 8	13328	2
7	5/8" Flat Washer	13975	2
8	8 Tooth Sprocket	23747	2
9	1/2" x 4.0" Bolt	23540	8
10	Hydraulic Motor Left Hand Right Hand Seal	22586 26133 22820	1 1
11	1/2" Nylon Lock Nut	10241	8
12	5/16" x 1-3/4" Bolt	21726	2
13	Hose Clamp Top 1/2"	21725	2
14	Hydraulic Hose Clamp 1/2"	21561	4



## Loading fork

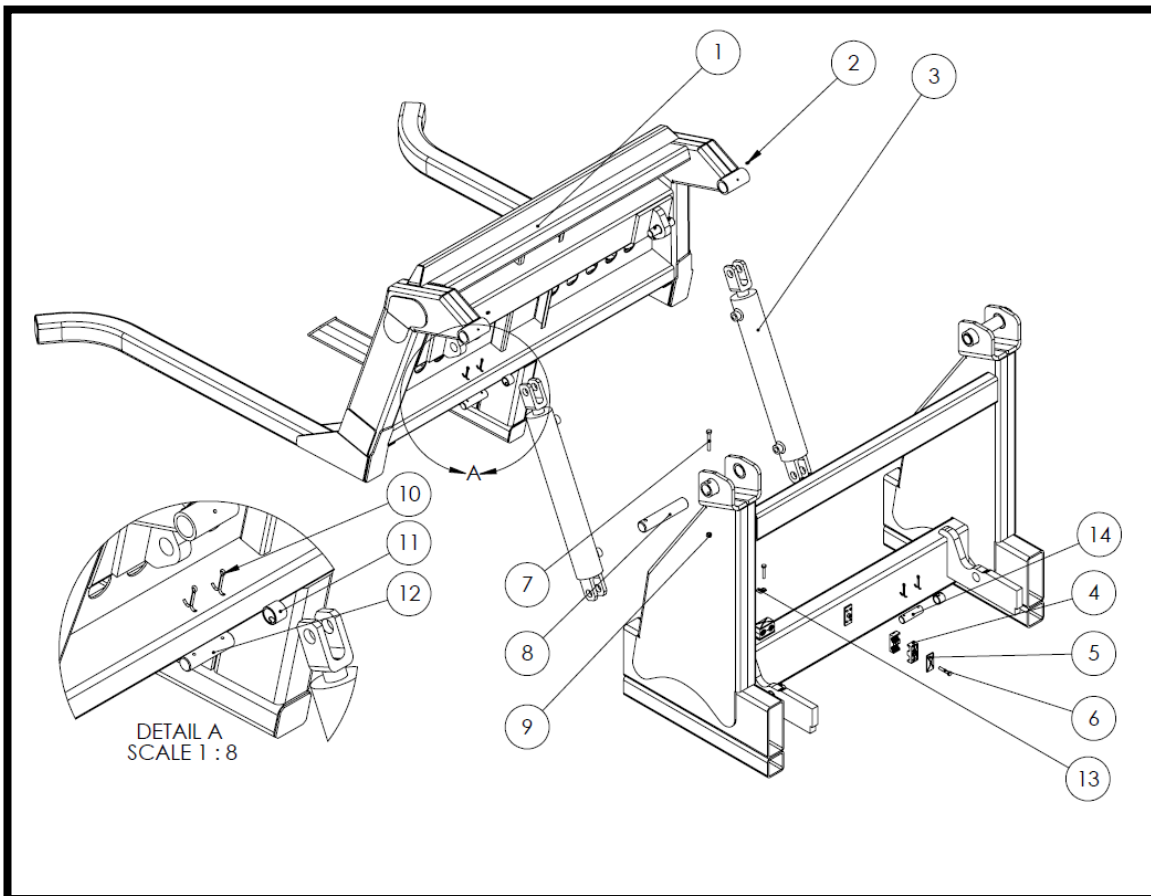

Item #	Description	ID number	QTY.
1	Back Fork	24705	1
2	Grease Zerk	16364	2
3	Hydraulic Cylinder (3 x 18 x 1.5)	21717	2
4	Hydraulic Hose Clamp 1/2"	21561	14
5	Hose Clamp Top 1/2"	21725	7
6	5/16" x 1-3/4" Bolt	21726	7
7	3/8" x 2-3/4" Bolt	20908	2
8	Fork Pivot Pin	22006	2
9	3/8" Nylon Lock Nut	10806	2
10	Cotter Pin 93/16" x 1-1/2")	10072	8
11	Spring Bushing ( 1" Pin)	23708	4
12	Cylinder Pin (1" x 4-1/16")	22190	2
13	Wiring Clamp	13629	4
14	Cylinder Pin (1" x 3-1/2")	10339	2



## Fine chop

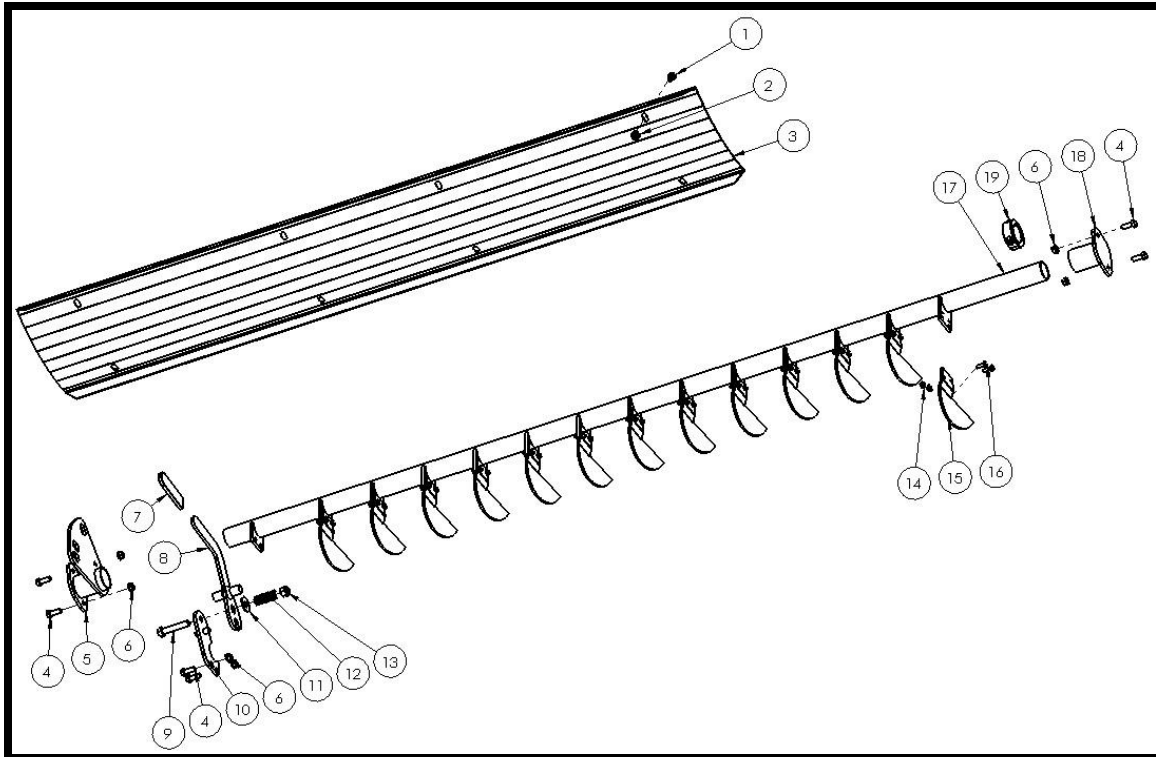

Item #	Description	ID number	QTY.
1	3/8" x 3/4" Fin Bolt	10807	8
2	3/8" Serrated Flange Nut	10271	8
3	Fine Chop Slot Cover	22438	1
	Fine Chop Kit *Option*	22139	1
4	3/8" x 1" Bolt	13806	6
5	Fine Chop Mount (Front)	22443	1
6	3/8" Serrated Flange Nut	10271	6
7	Rubber Handle	10297	1
8	Fine Chop Handle	22446	1
9	1/2" x 2-1/2" Bolt	10804	1
10	Fine Chop Handle Mount	22445	1
11	1/2" Flat Washer	11668	1
12	Fine Chop Handle Spring	21713	1
13	1/2" Nylon Lock Nut	10241	1
14	1/4" Serrated Flange Nut	11812	26
15	Fine Chop Blade	10404	13
16	1/4" x 3/4" Bolt	11809	26
17	Fine Chop Bar	22442	1
18	Fine Chop Mount (Rear)	22444	1
19	Split Collar	12792	1



## Control Box

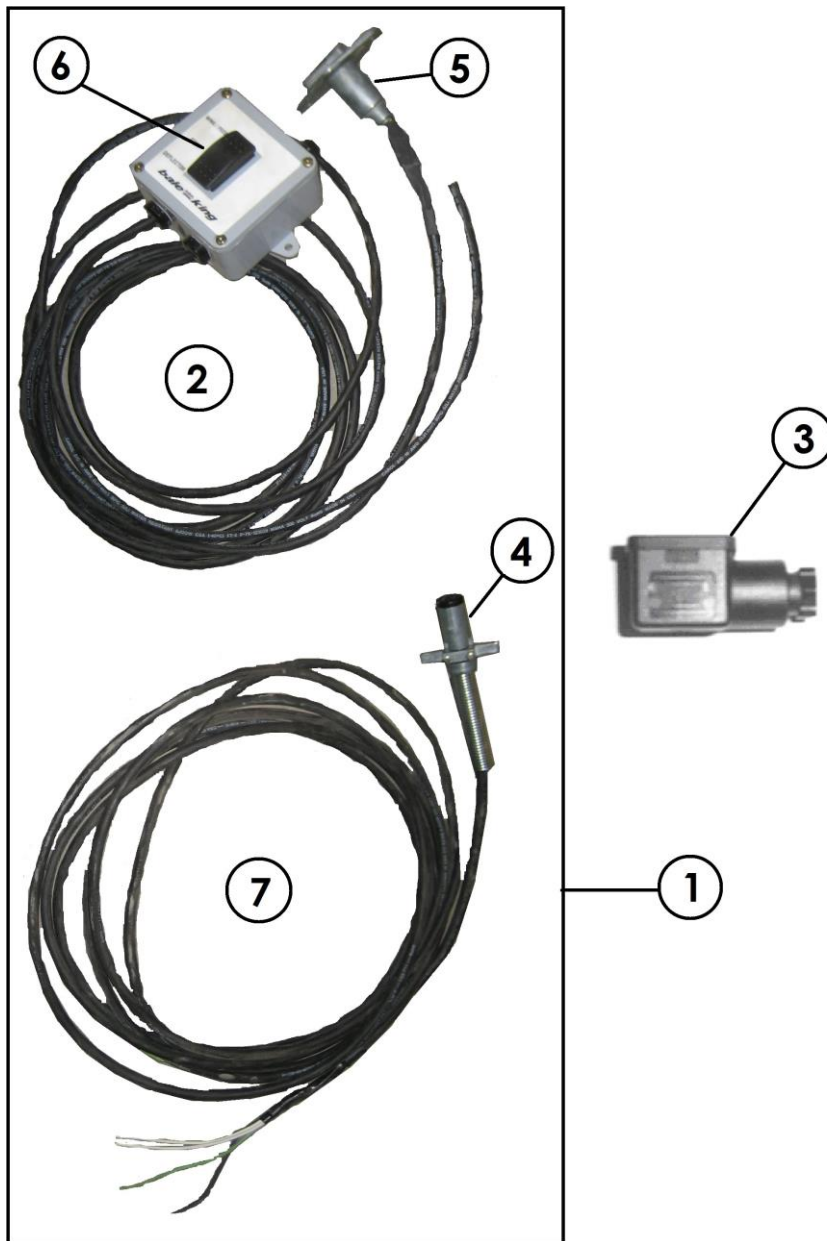

Item #	Description	ID number	QTY.
1	Complete control box with harness (6105)	23988	1
2	Control box complete with cab to hitch harness (6105)	-	1
3	Square plug for diverter valve	13657	2
4	4-pin trailer plug	24961	1
5	4-pin tractor plug	24960	1
6	3-way switch	13561	1
7	Harness (hitch to valve 6105)	24693	1



# Decal





7



8

9

Item #	Description	ID number	QTY.
1	PTO Caution	12219	2
2	Stand Clear of Lift	12229	2
3	Side Discharge	12230	4
4	PIMA/AMC	12239	1
5	Red Reflective	13324	3
6	Amber Reflective	13325	3
7	Bale King 6105	24767	2
8	Hoop Adjustment	22165	1
9	Deflector Lock	22292	1







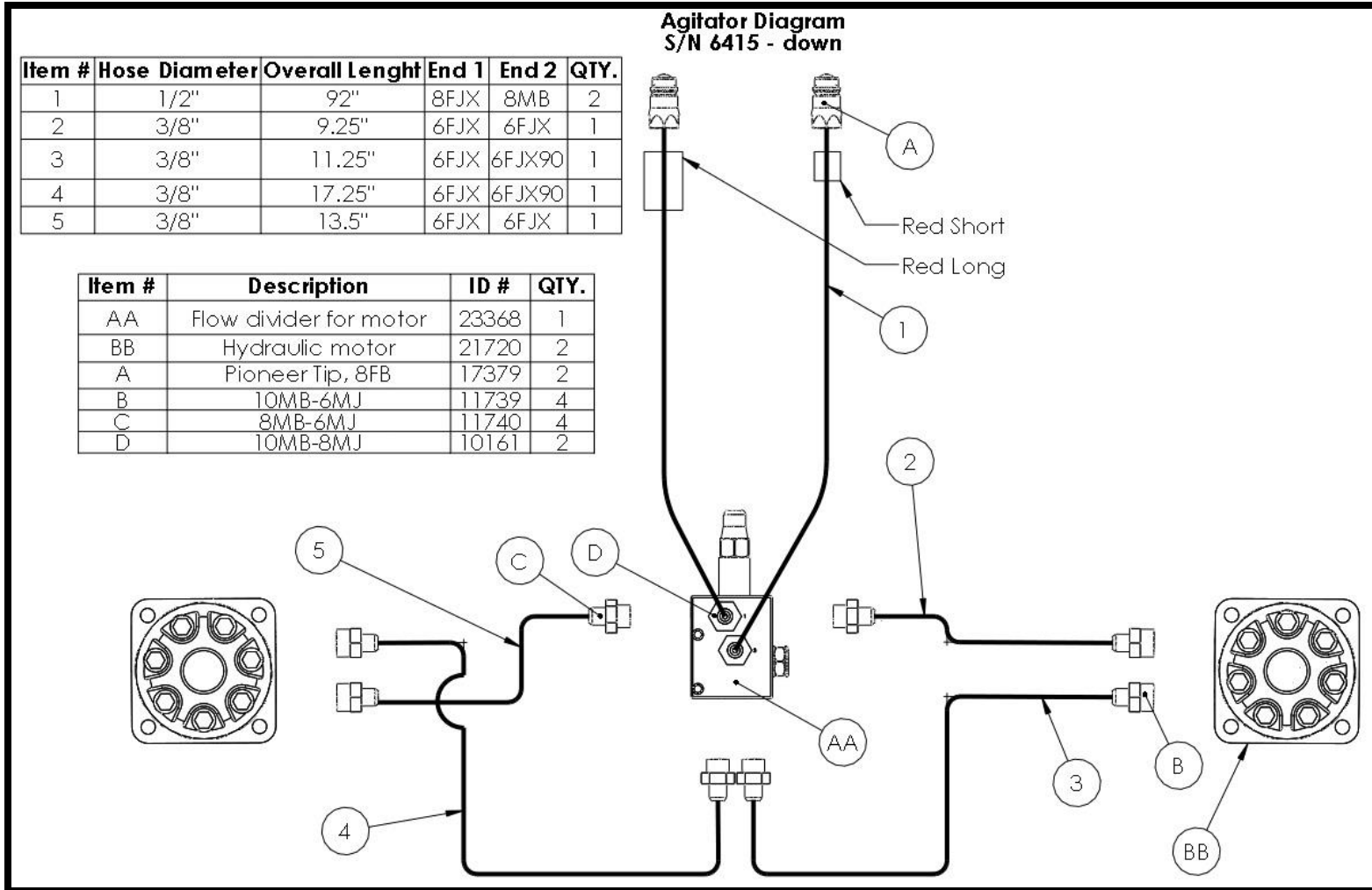



## Conveyor Chain Motor

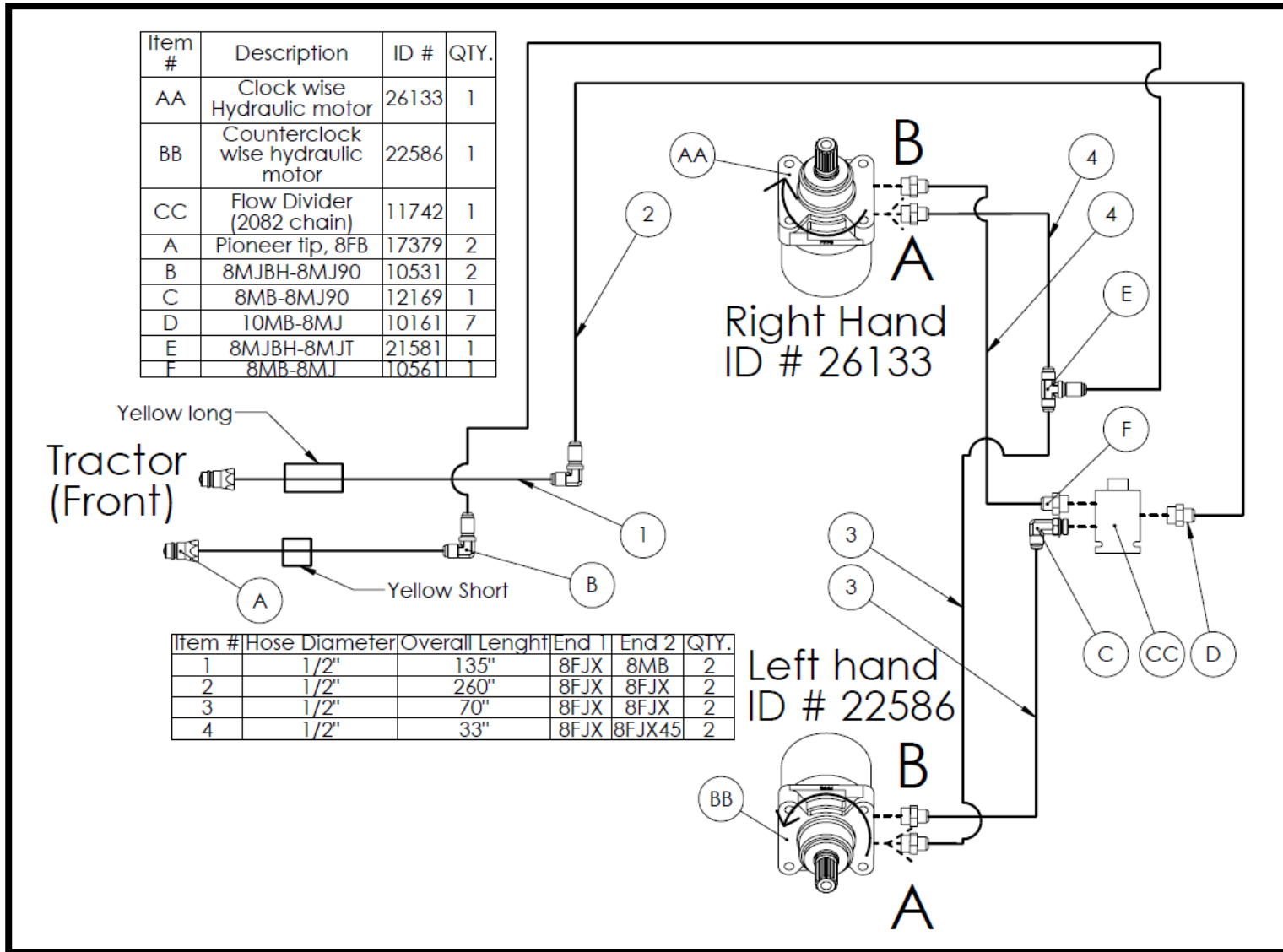



## Tilt/Fork/Deflector

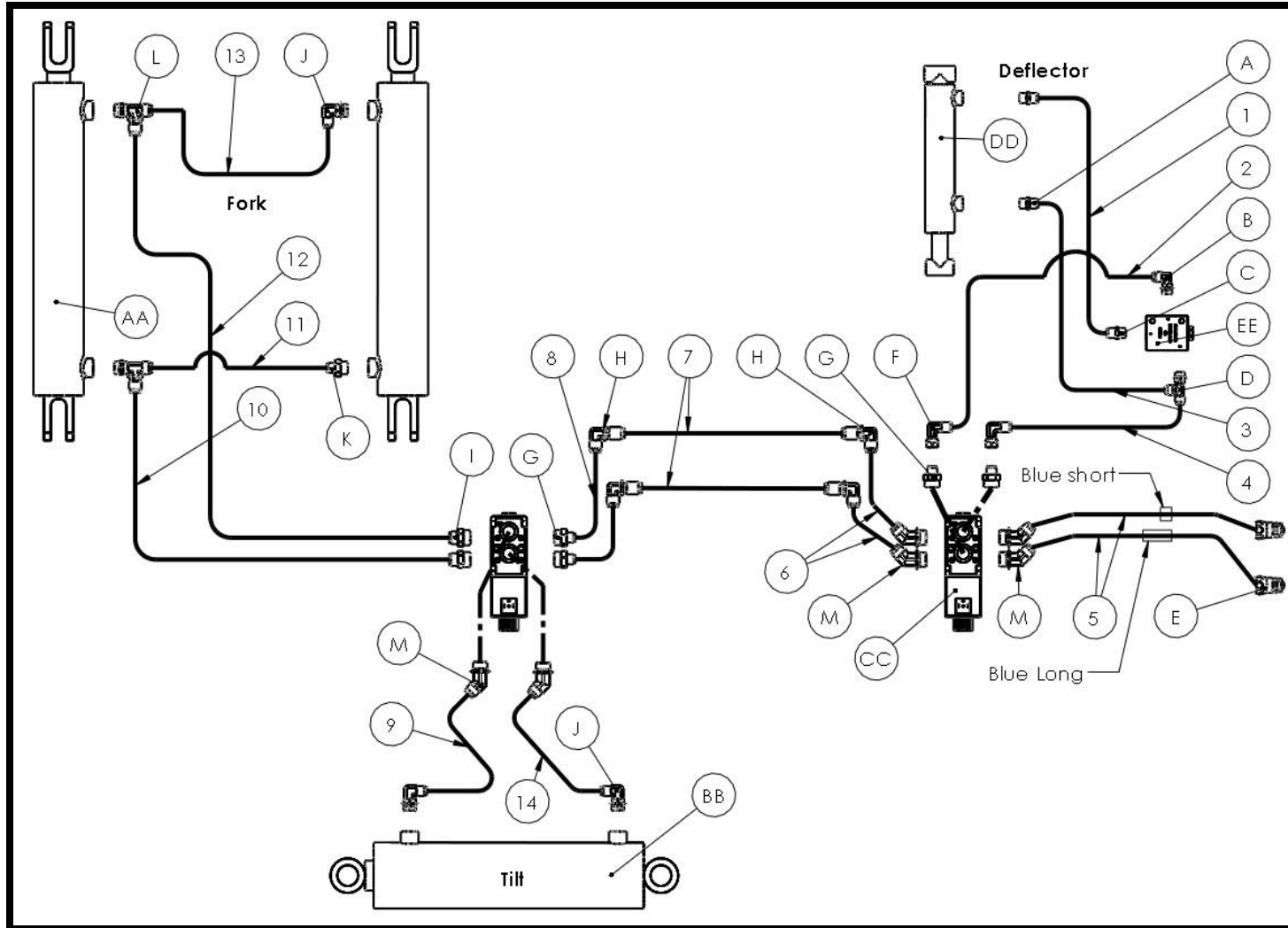

S/N 6480 - up

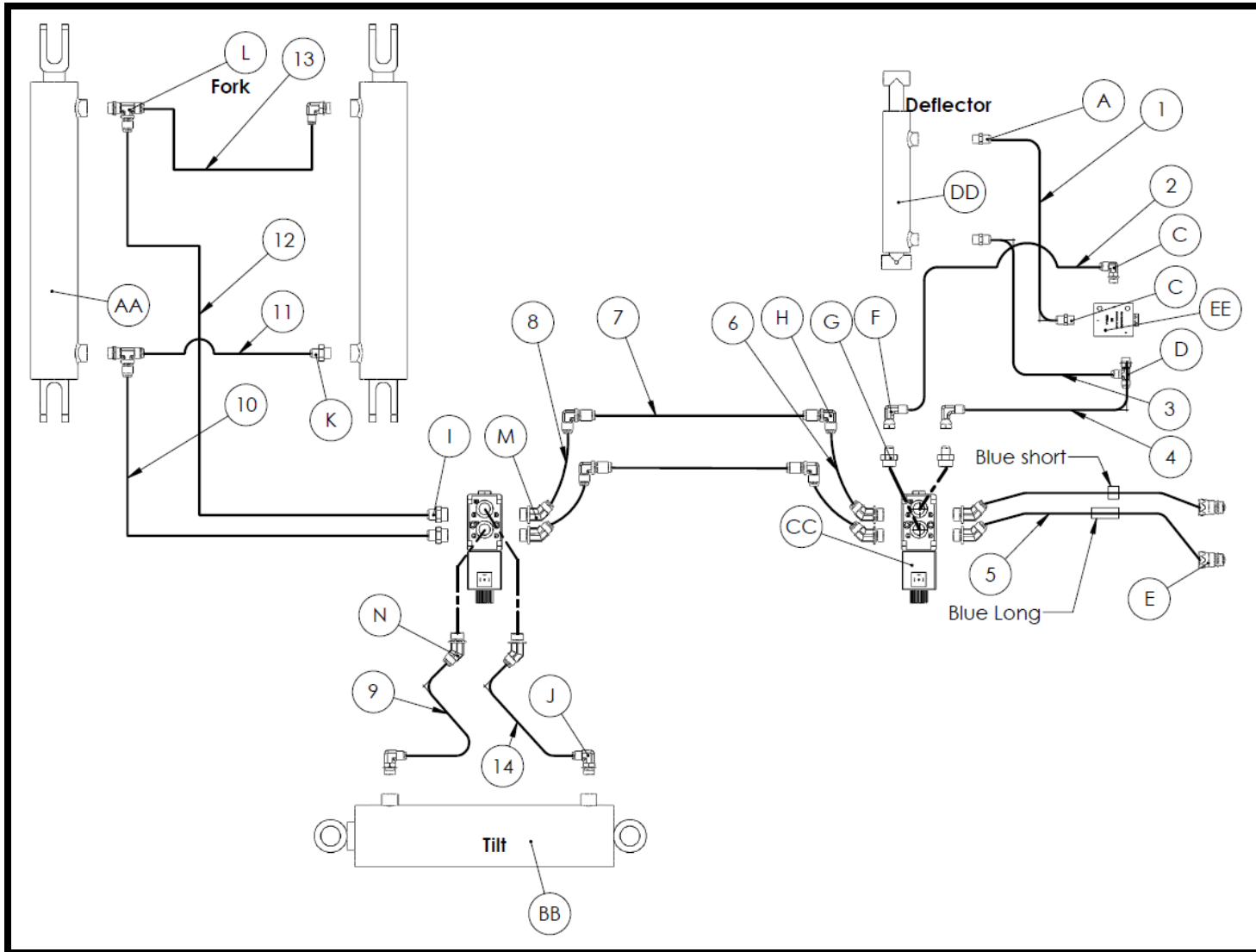

Figure 1S/N6479 - down



**S/N 6480 - up**

Item #	Description	ID #	QTY.
AA	Hydraulic Cylinder (3 x 18 x 1.5)	21717	2
BB	Hydraulic cylinder (4 x 12 x 2)	23094	1
CC	Electrical Diverter valve	11743	2
DD	Hydraulic cylinder (1.5 x 6 x 1)	21711	1
EE	Pilot operated check valve	19114	1
A	6MB-6MJ(Orifice)	18074	2
B	6MB-6MJ90	10201	1
C	6MB-6MJ	10162	1
D	6MBR-6MJT	23726	1
E	Pioneer Tip, 8FB	17379	2
F	6FJX90-6MJ	12162	2
G	10MB-6MJ	11739	4
H	6MJBH90	10187	4
I	10MB-8MJ	10161	2
J	8MB-6MJ90	10200	3
K	8MB-6MJ	11740	1
L	8MBR-8MJT	22159	2
M	10MB-6MJ45	22722	6

**S/N 6479 - down**

Item #	Description	ID #	QTY.
AA	Hydraulic Cylinder (3 x 18 x 1.5)	21717	2
BB	Hydraulic cylinder (4 x 12 x 2)	23094	1
CC	Electrical Diverter valve	11743	2
DD	Hydraulic cylinder (1.5 x 6 x 1)	21711	1
EE	Pilot operated check valve	19114	1
A	6MB-6MJ(Orifice)	18074	2
B	6MB-6MJ90	10201	1
C	6MB-6MJ	10162	1
D	6MBR-6MJT	23726	1
E	Pioneer Tip, 8FB	17379	2
F	6FJX90-6MJ	12162	2
G	10MB-6MJ	11739	2
H	8MJBH-8MJ90	10531	4
I	10MB-8MJ	10161	2
J	8MB-6MJ90	10200	3
K	8MB-6MJ	11740	1
L	8MBR-8MJT	22159	2
M	10MB-8MJ45	23844	6
N	10MB-6MJ45	22722	2

ITEM#	Hose Diameter	Overall Length	End 1	End 2	QTY
1	1/4"	12.25"	6FJX	6FJX90	1
2	1/4"	20.25"	6FJX	6FJX90	1
3	1/4"	16.25"	6FJX	6FJX90	1
4	1/4"	13.5"	6FJX	6FJX	1
5	3/8"	125"	6FJX	8MB	2
6	3/8"	8.75"	6FJX	6FJX	2
7	3/8"	79.5"	6FJX	6FJX	2
8	3/8"	16.25"	6FJX	6FJX	2
9	3/8"	179"	6FJX	6FJX	1
10	3/8"	35"	8FJX	8FJX	1
11	3/8"	33.5"	6FJX	8FJX	1
12	3/8"	53"	8FJX	8FJX	1
13	3/8"	78"	6FJX	8FJX90	1
14	3/8"	171"	6FJX	6FJX90	1

ITEM#	Hose Diameter	Overall Length	End 1	End 2	QTY
1	1/4"	12.25"	6FJX	6FJX90	1
2	1/4"	20.25"	6FJX	6FJX90	1
3	1/4"	16.25"	6FJX	6FJX90	1
4	1/4"	13.5"	6FJX	6FJX	1
5	1/2"	125"	8FJX	8MB	2
6	1/2"	8.75"	8FJX	8FJX	2
7	1/2"	79.5"	8FJX	8FJX	2
8	1/2"	15"	8FJX	8FJX	2
9	3/8"	179"	6FJX	6FJX	1
10	3/8"	35"	8FJX	8FJX	1
11	3/8"	33.5"	6FJX	8FJX	1
12	3/8"	53"	8FJX	8FJX	1
13	3/8"	78"	6FJX	8FJX90	1
14	3/8"	171"	6FJX	6FJX90	1



## Light Diagram

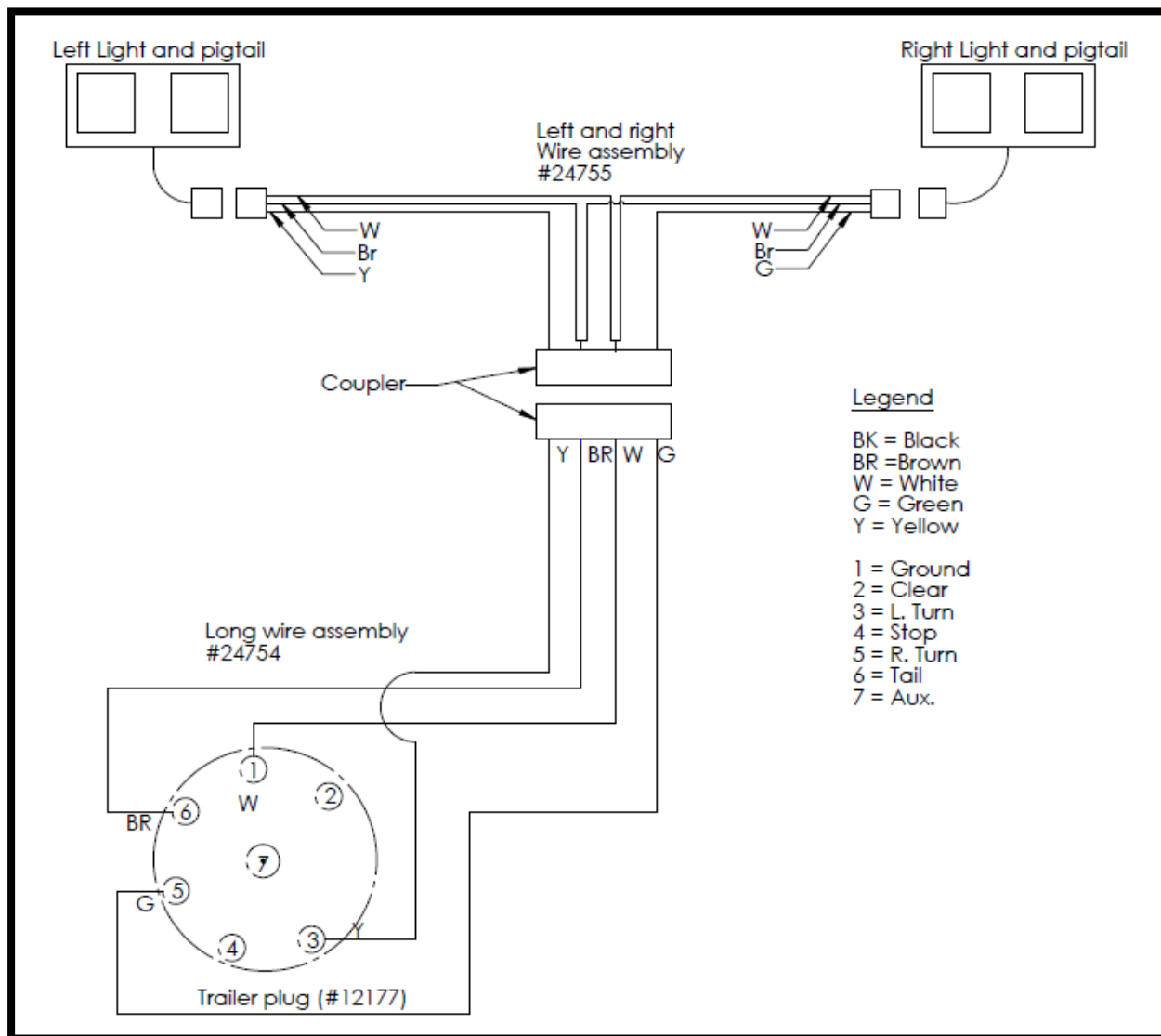



## Diverter Diagram

*Machine side*

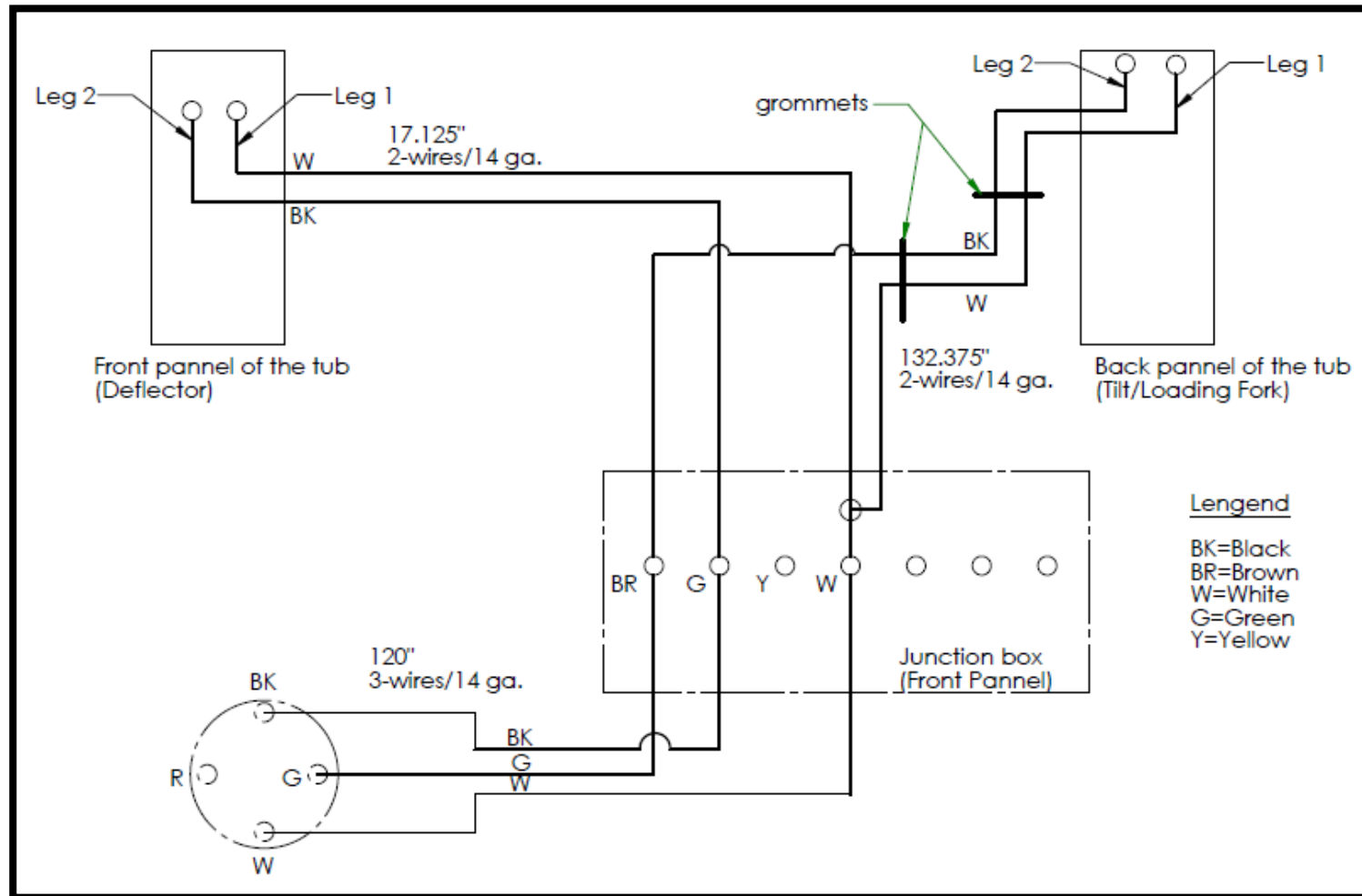





**Tractor Side (Control Box #23988)**

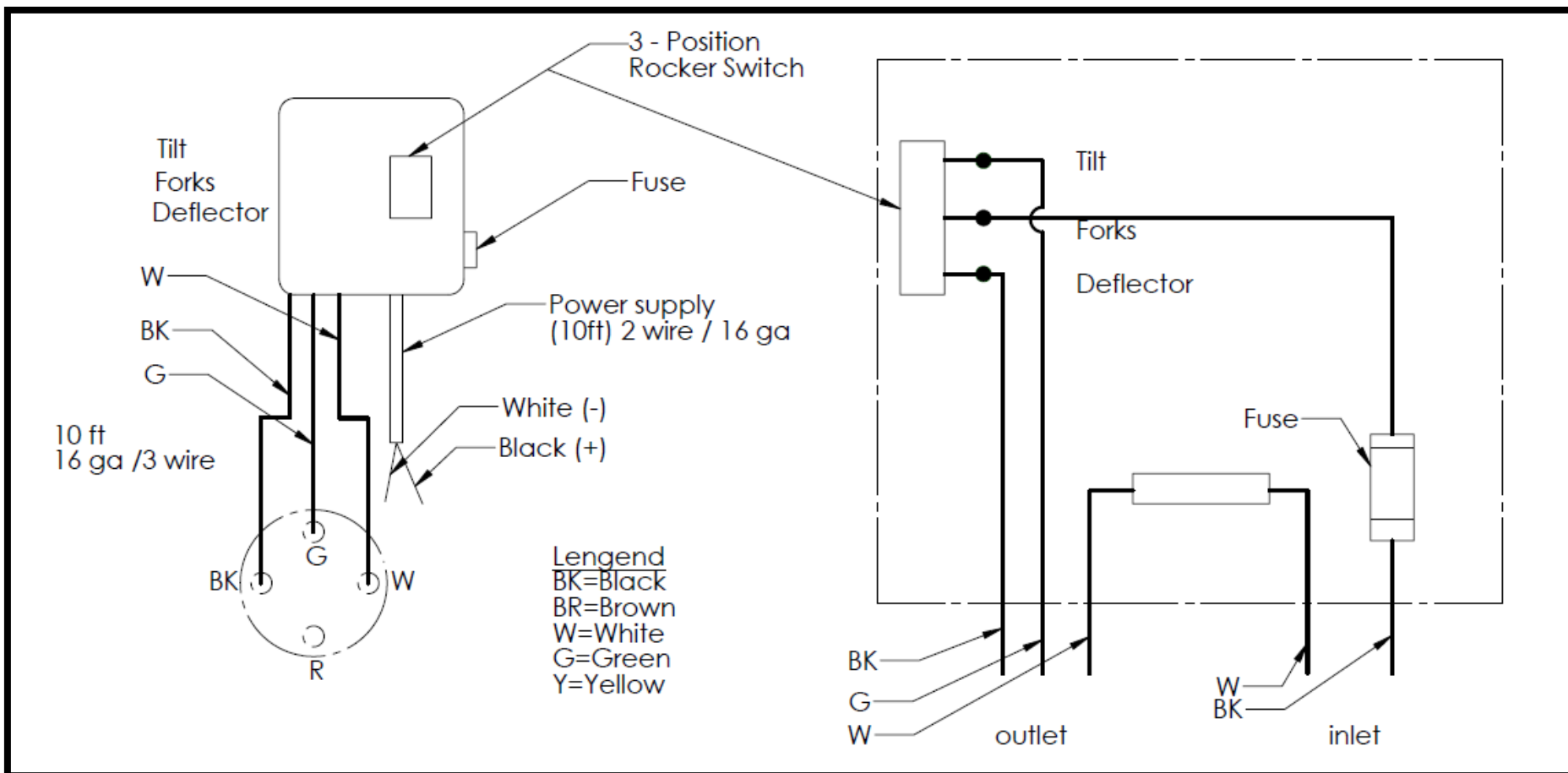





**BRIDGEVIEW MANUFACTURING INC.**

P.O. BOX 4, HWY 22  
GERALD, SASK. S0A 1B0  
CANADA

Ph: 306-745-2711

Fax: 306-745-336

Email: [bmi@sasktel.net](mailto:bmi@sasktel.net)

[www.bridgeviewmanufacturing.com](http://www.bridgeviewmanufacturing.com)