

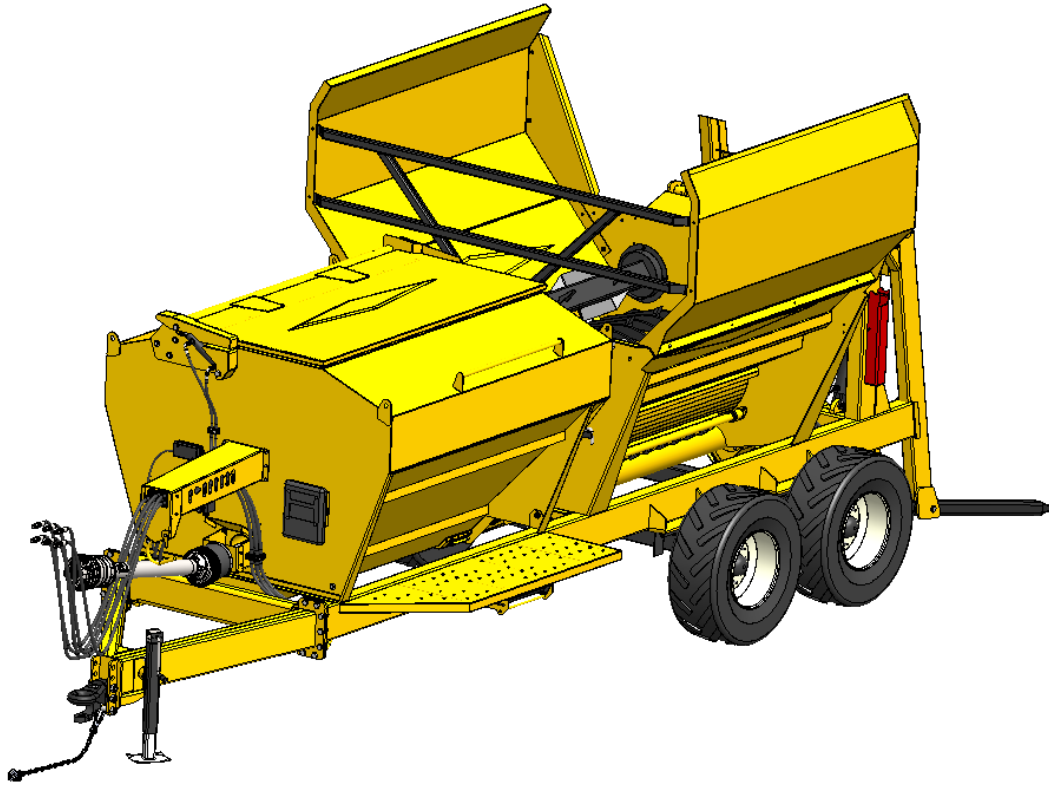

BRIDGEVIEW



Bale King 5225 Bale Processor

DELIVERY SET-UP **INSTRUCTIONS**

Last Updated: October 19, 2020

Bridgeview Manufacturing Inc.

P.O. Box 4

Gerald, SK

S0A 1B0

Phone: 1-306-745-2711

Fax: 1-306-745-3364

Email: bmi@sasktel.net

www.bridgeviewmanufacturing.com



When your new Bale King 5225 arrives by truck, there are a few things that must be done before it is ready for use. This manual will offer step-by-step instructions.

1. Unfold side deflector

Remove the four 1/2"x 1" bolts and serrated flange nuts connecting the two deflector pieces. Set the outside deflector piece on the ground and lower the deflector (remove safety lock first). Slide the outer deflector piece back on and put in the CENTER POSITION. Reinstall the 1/2" x 1" bolts, and install the 3/8"x 3/4" bolts along the top connection. Tighten all bolts. Plug the 3 exposed holes with 3/8" bolts as well.

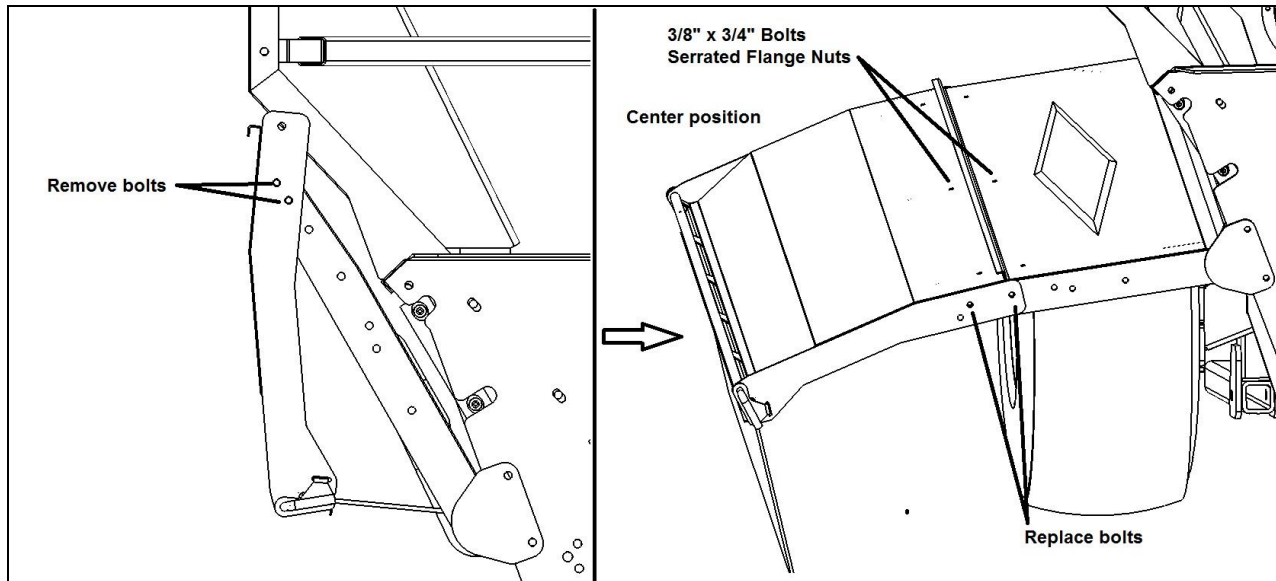

WARNING: Do not swing the deflector down before the deflector is unfolded. It will hit the tire.



2. Install rear forks

- Remove the rear fork safety lock by first lifting the forks fully using the blue hydraulic hoses.
- Place locks in storage location along sides
- Lower forks and install tines as shown

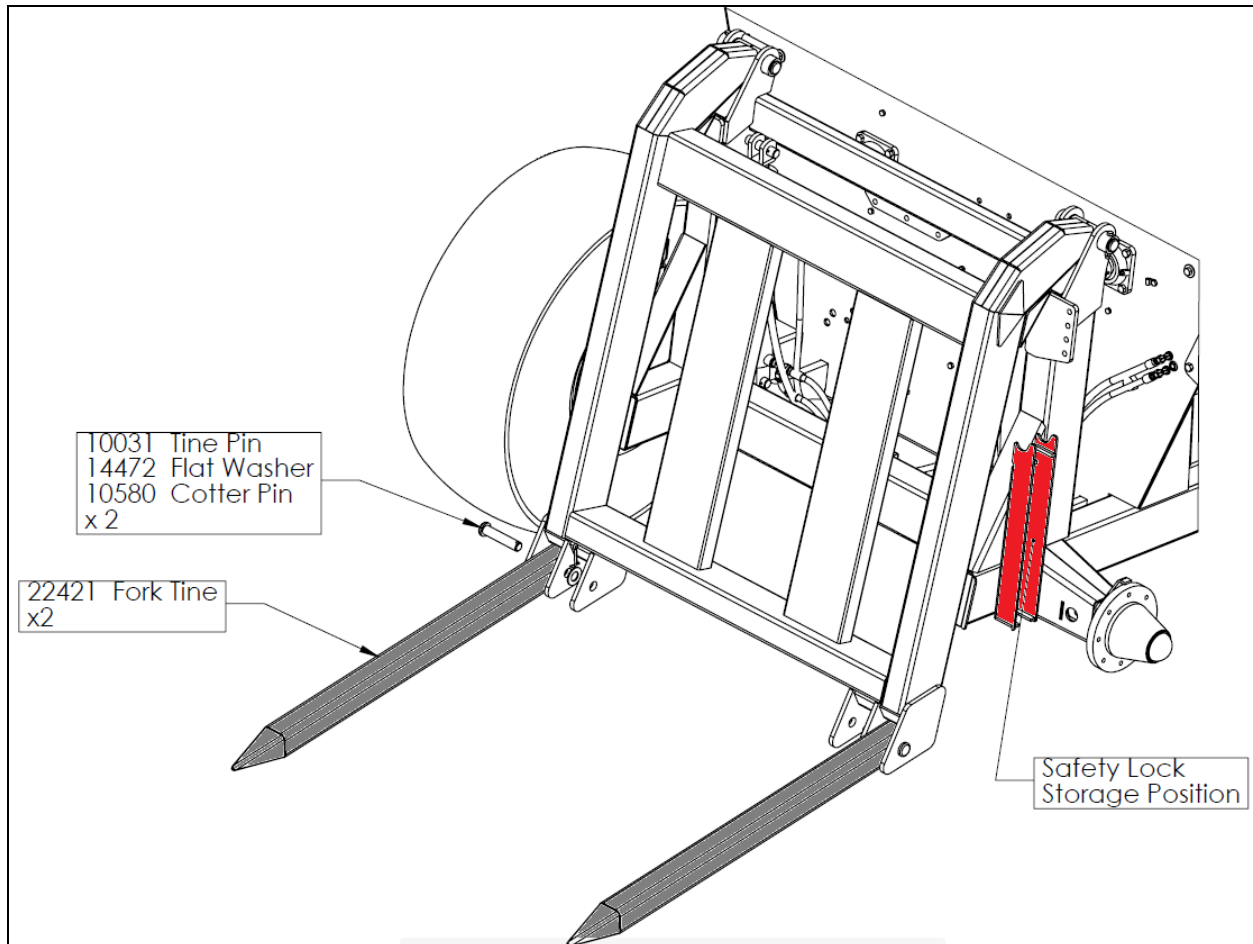



3. Install PTO Shaft

Slide the outer PTO shaft into the inner shaft. Align the spot welded spline with the slot in the inner shaft.

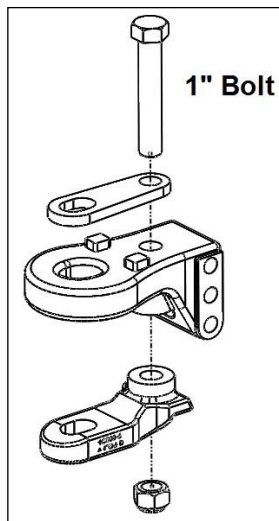
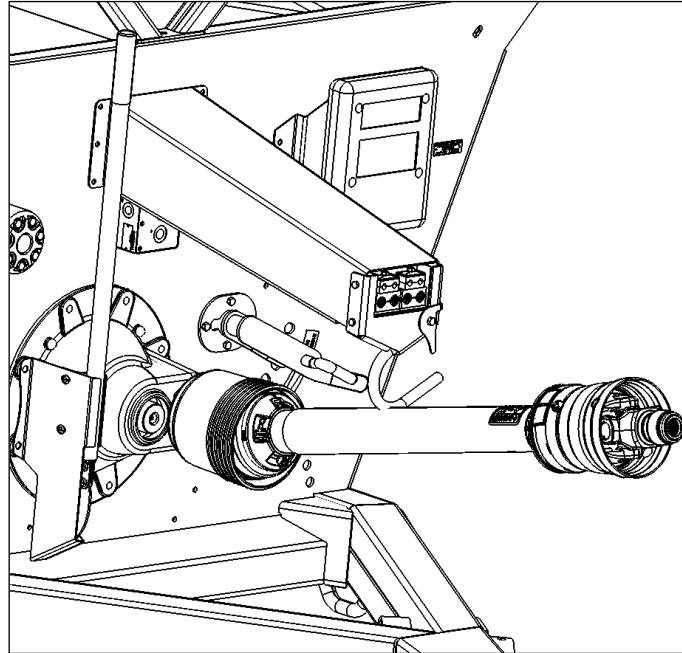

4. Clevis Option

If the operating tractor does not have a hammer strap it is recommended to install this clevis. Otherwise, it is not recommended.