

CHIEF

ASSEMBLY MANUAL

21' (40°) Hopper cone

Maximum Capacities

	<u>STD</u>	<u>HD</u>
21' - 40°	191.4t	312.1t

Jun 27, 2007

Step 1: -Verify that all parts are available according to the packing slip.
-If a skid is used, go to step 2. If no skid is used, go to step 3.

Step 2: -If a skid foundation is used, set up the skid with the 5/8" hardware provided.
-Level the skid and tighten the skid bolts. Support the skid on 4"x4" blocks (Not supplied) to allow for easy access to the bolts attaching the legs to the skid.
-Stand the legs up and loosely attach to the skid using the 3/4" bolts.
(Brace clips facing the inside of the cone)
-When all the legs are installed, connect the web pieces to the legs to form the ring. Use 5/8 hardware. Note: Bolts must be installed from the outside.
(Nuts will be towards the inside of the bin)

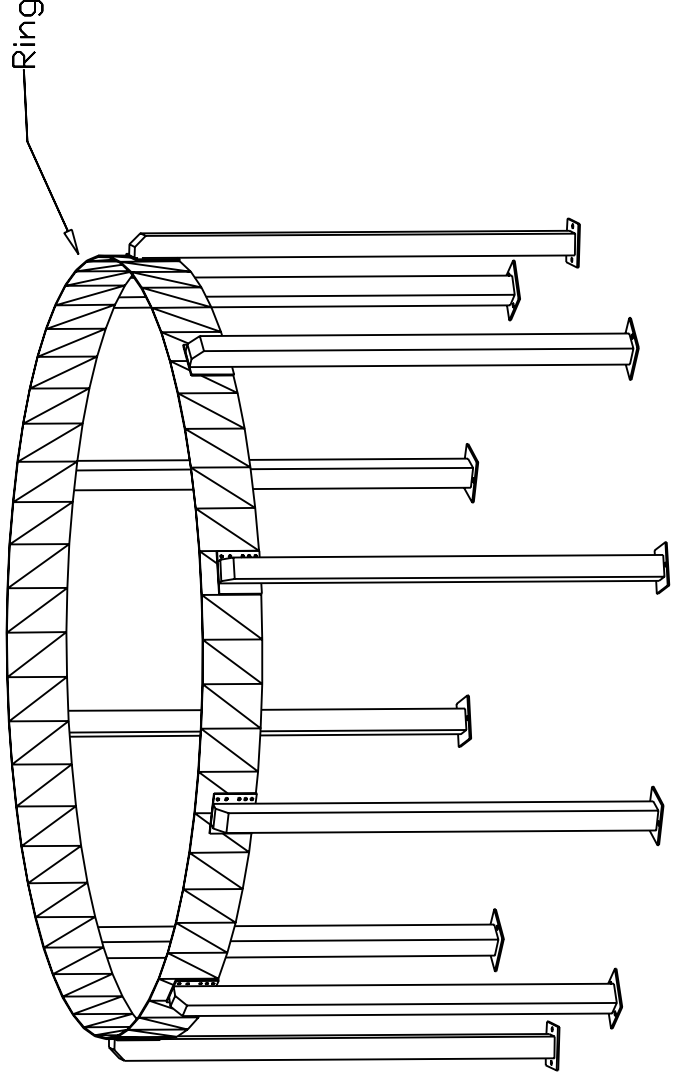

- Step 3: - If NO SKID is used, assemble 3 legs to 2 pieces of band.
using 5/8" hardware. Note: Bolts must be installed from the outside.
(The nuts will be towards the inside of the Hopper cone)
- Stand this section up and support.
 - Continue adding legs and band pieces until the full circle is complete. (DO NOT TIGHTEN BOLTS UNTIL FULL STRUCTURAL BRACES ARE IN PLACE ARE IN PLACE)
 - Level all of the legs.

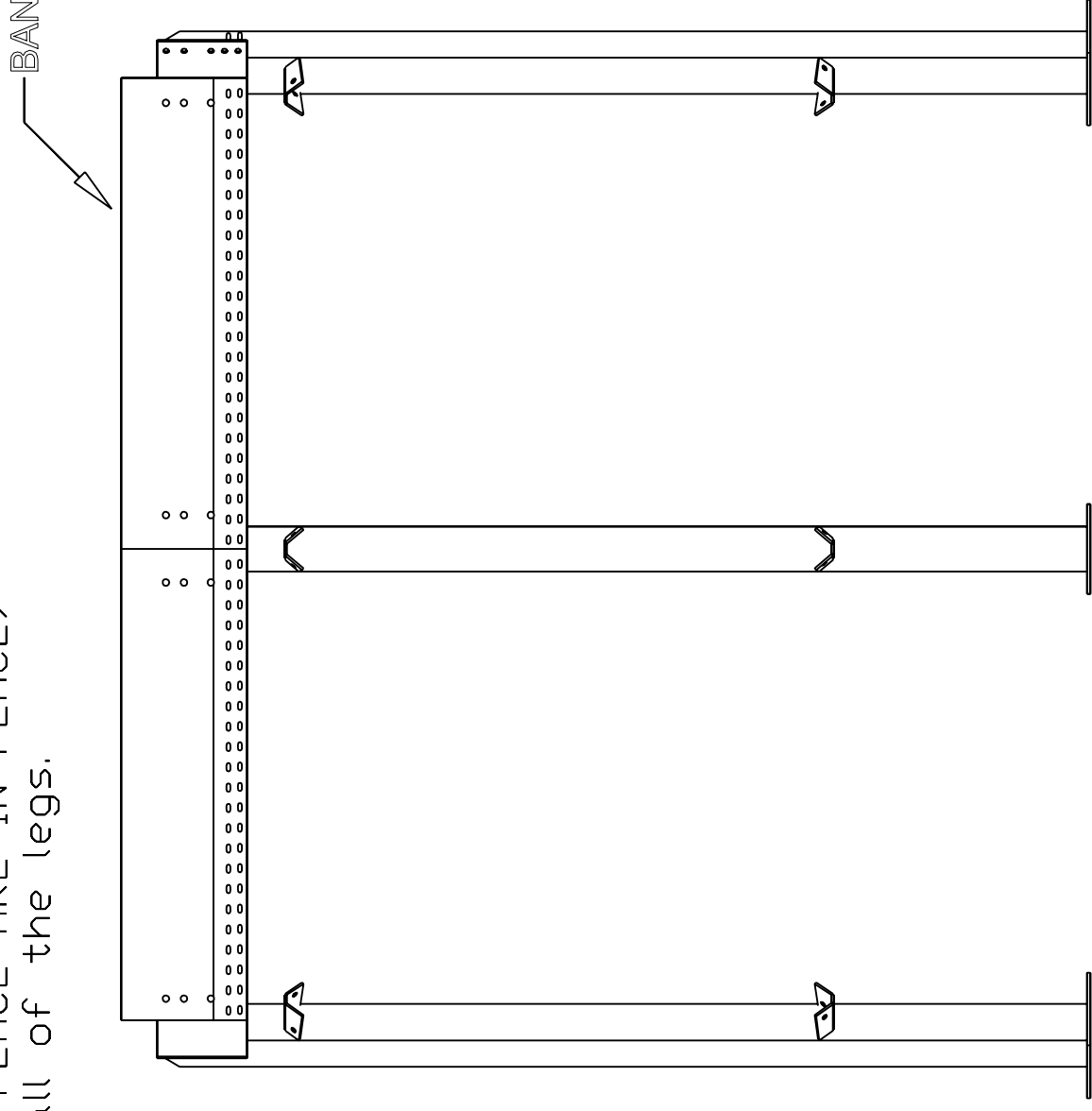

Step 4.1:

- Ensure that the legs are level.
- Install channel braces (X braces) in an X pattern using 5/8" hardware.
- X Braces are bolted on so that the "C Channel" faces downward.
(So that it won't hold water)

Step 4.2:

- If lateral braces are included in the kit continue on if not then go to 4.3
- Install braces at the top of the leg using 5/8" hardware.
- Lateral braces are bolted on so that the "C Channel" faces downward.

Step 4.3:

- After all the braces are installed, tighten the brace bolts and then the ring bolts.

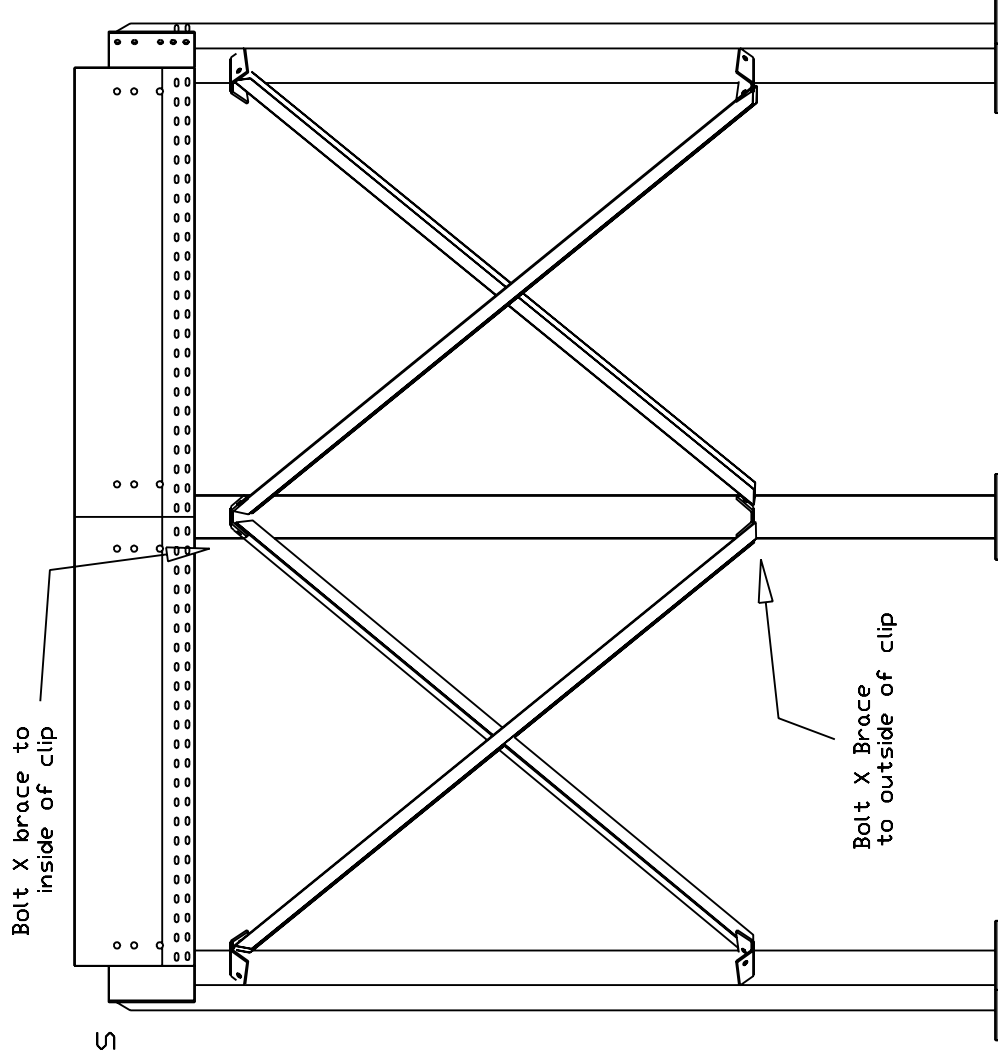

If your bin package includes lateral braces, attach them to the top and middle brace clips

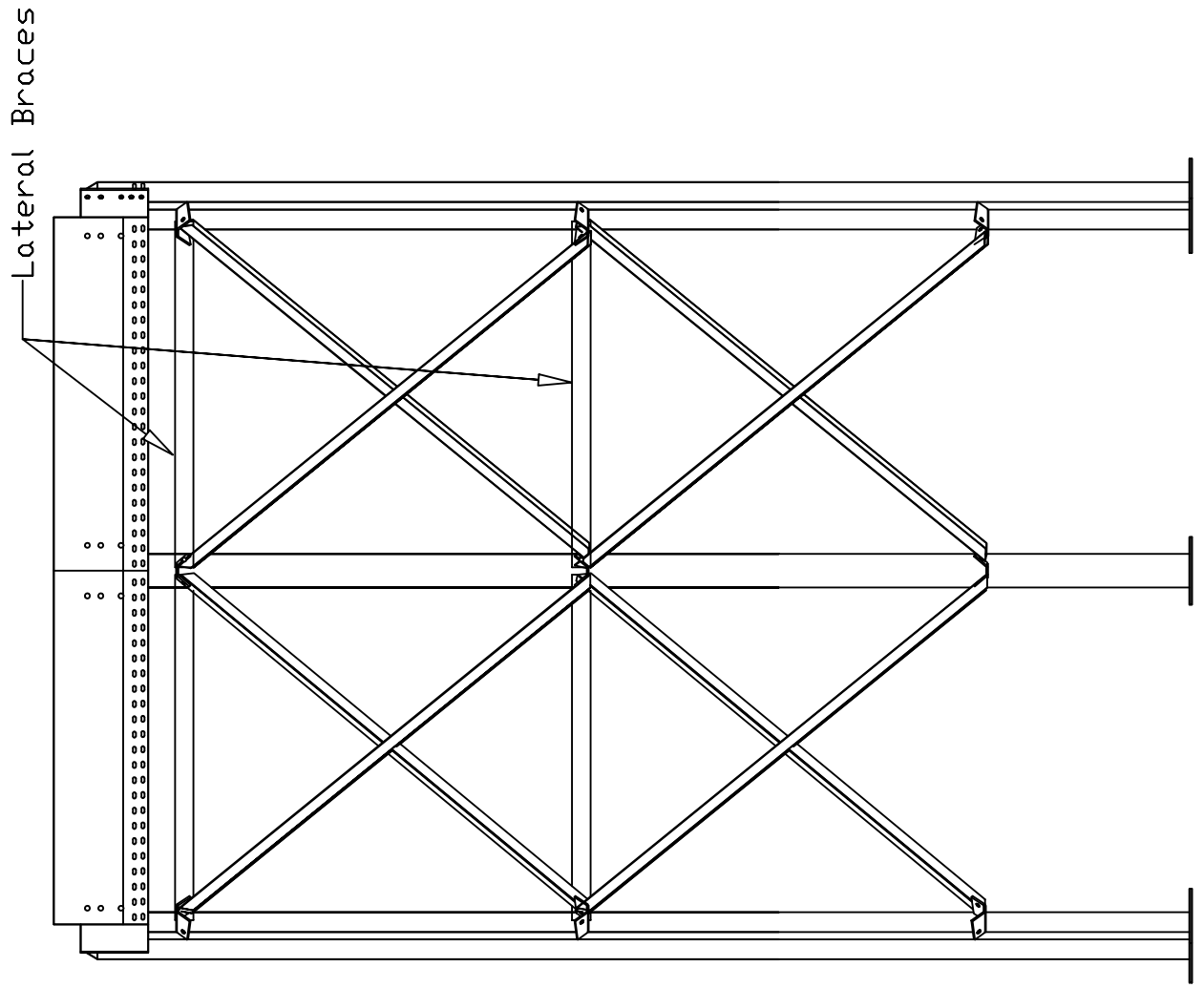

STEP 5

- Install upper galvanized sheets on the top web starting with the center of the sheet lining up with the seam on the band. Use the 3/8" hardware. Install all band bolts and then add the next sheet in a counterclockwise direction. (Formed edge will be on outside). Install the bolts from the inside out. (the nuts will be on the outside of the cone. This ensures better clean out inside the bin). Always install the band bolts before doing the seams.

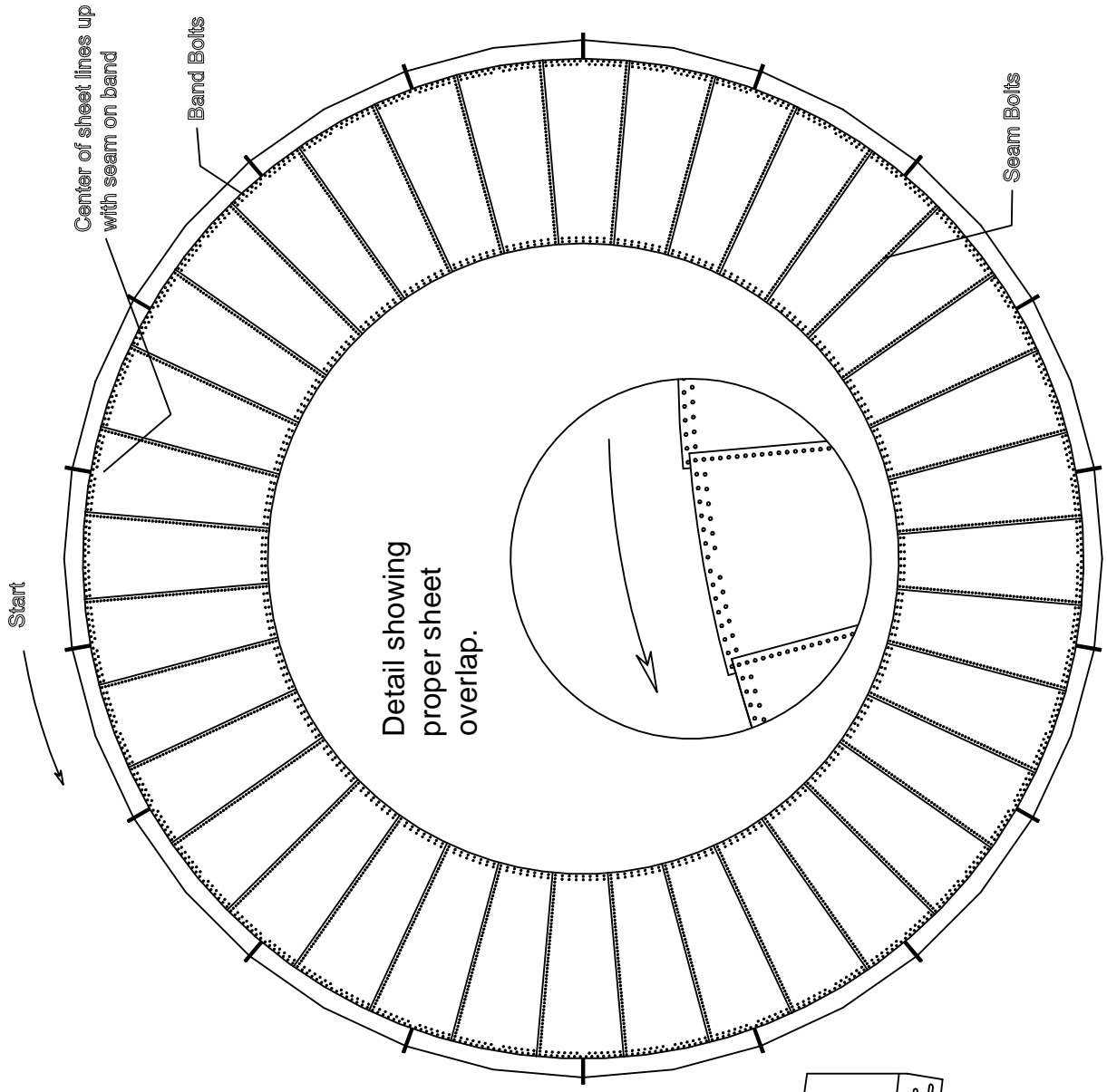

(Looking down on hopper)

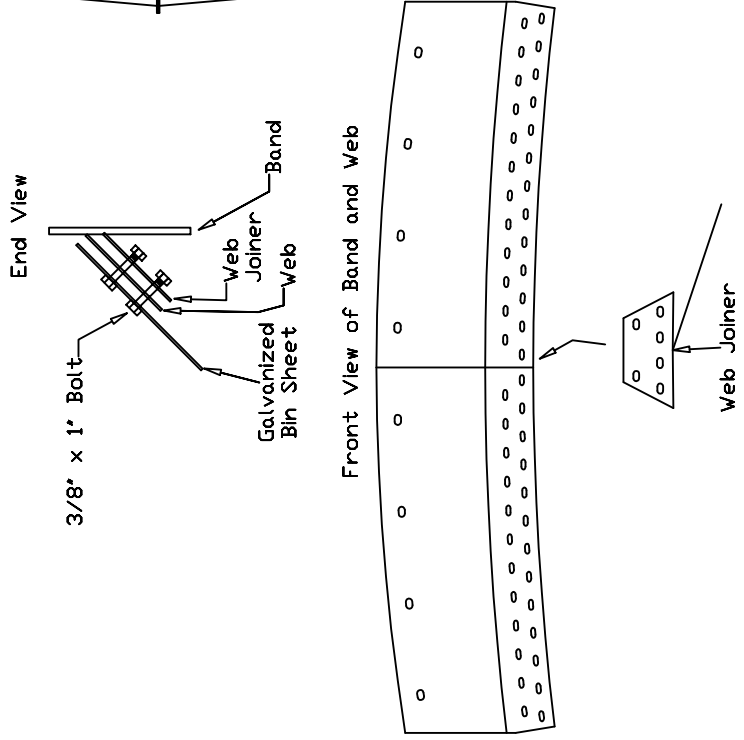

Center web joiner on seam and bolt to underside of web.

Step 6:

Install the lower galvanized sheets

- 1: Align the seams on the first top and bottom sheet
- 2: Bottom sheet laps upper sheet to the outside.
- 3: Proceed in CLOCKWISE direction Formed edge will be on outside.

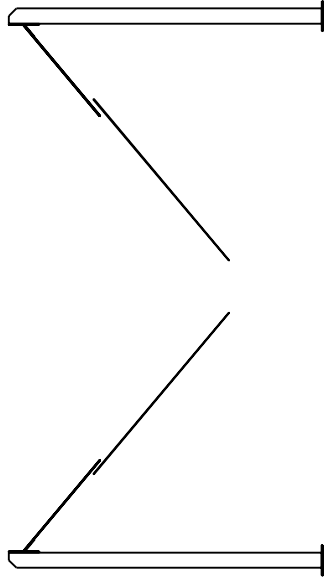

2: Bottom sheet laps upper sheet to the outside

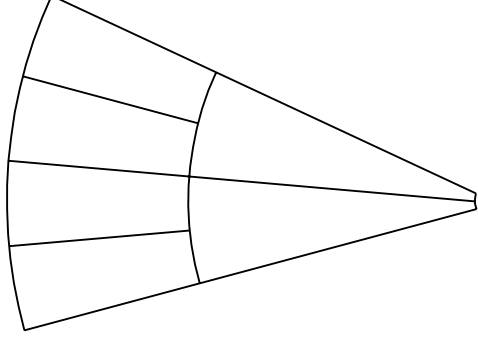

1: Line up seams.

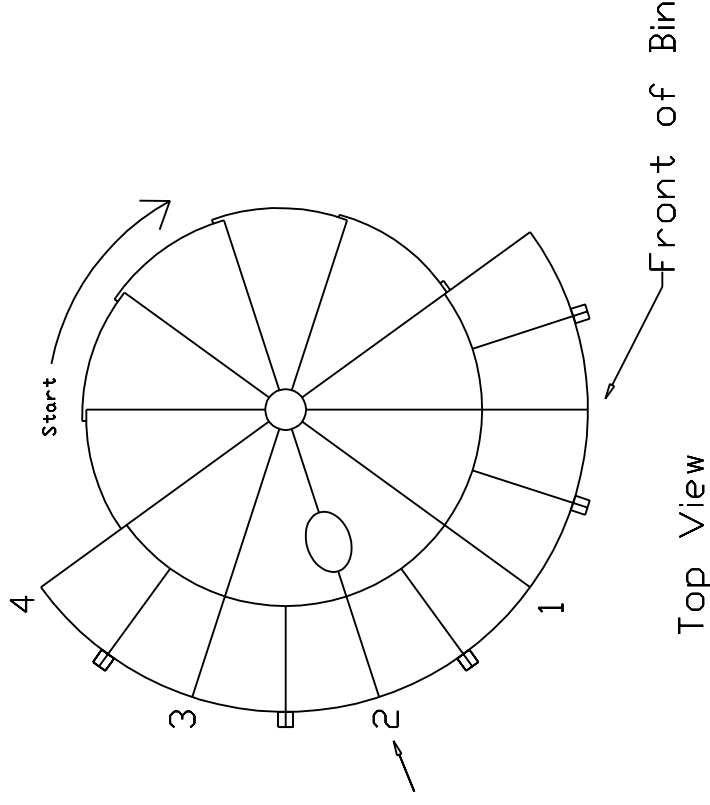

Top View

- 3: Formed edge on outside (Looking down on hopper from above)
Note: Manhole location relative to bin front is shown above (if equipped)

Step 7: (if manhole equipped only)

Manhole cover should be placed inside bin and manhole flange installed from outside of bin as shown below in 1.

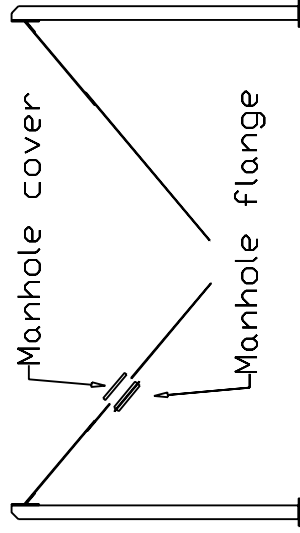

1: Manhole flange bolts to outside of cone

Step 8:

Install Chute. Chute bolts to outside of the cone as shown in 2. The rotation of the chute relative to the front of the bin is shown in 3.

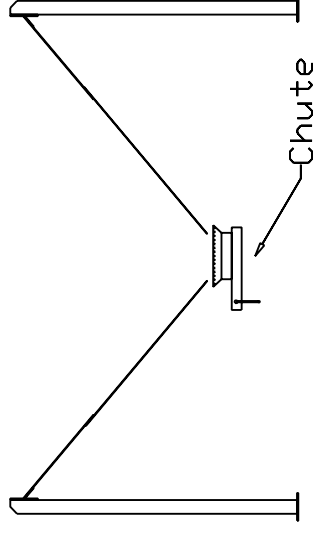

2: Chute bolts to bottom of cone

3: It is recommended the the chute be installed as shown at right. But user preference shall prevail.

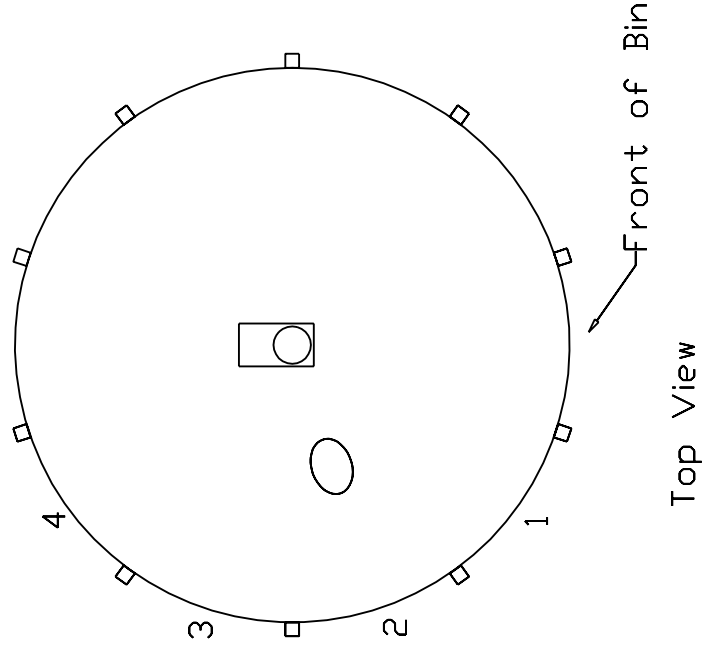

Top View